

O.P. (MM)	P.T. (MM)
8.80 ± 0.8	1.60 MAX.

O.P. = OPERATING POINT
P.T. = PRE-TRAVEL

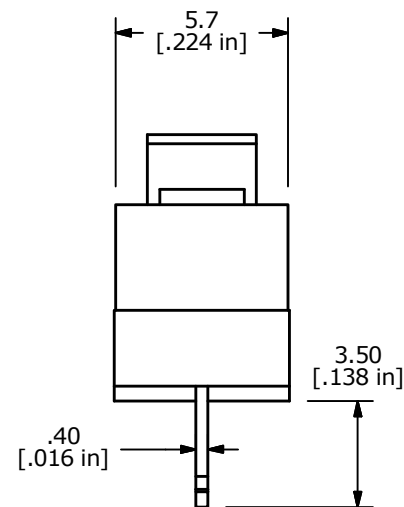
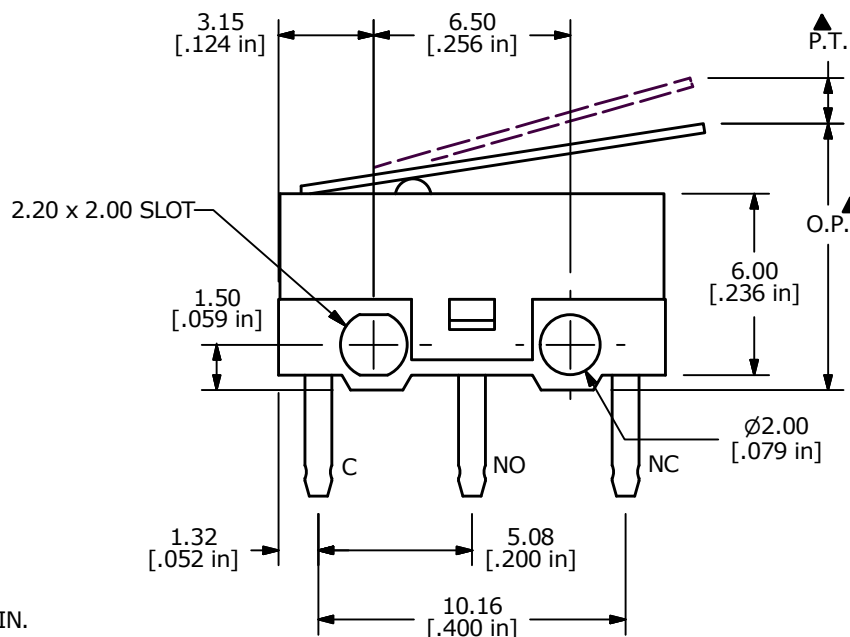

- NOTES:
1. ALL DIMENSIONS IN MM [INCH]
 2. GENERAL TOLERANCE: X.X±0.4
X.XX±0.25
 - ▲ 3. RATING: 3A @125VAC
1.5 A @ 250VAC UL
 4. OPERATING FORCE: 20 ±10 GRAMS
 5. OPERATING TEMP: -25°C TO 75°C
 6. ELECTRICAL LIFE: 10,000 CYCLES MIN.
 7. INSULATION RESISTANCE: 100 MEGA-OHMS MIN.
 8. DIELECTRIC STRENGTH: 500VAC - 1 MINUTE
 9. ▲ DENOTES CRITICAL PARAMETER.
 10. 2002/95/EC (ROHS) COMPLIANT
 11. PACKAGED IN TRAYS, 120 PIECES PER TRAY.

REV	PCR NO	DESCRIPTION	DATE	BY
F	22269	UPDATED DIMENSIONS	4/15/16	MJR
E	21626	CHG NOTE 4 FORCE TOLERANCE	10/14/14	AS
D	19095	CHANGE NOTE 4 (FORCE TOLERANCE)	5/25/10	BLR
C	18157	REMOVE CE APPROVED FROM NOTES	6/24/08	BLR



TITLE SS0750301F020P1A

THE INFORMATION CONTAINED IN THIS DOCUMENT IS PROPRIETARY TO E-SWITCH AND IS NOT TO BE COPIED OR TRANSFERRED

SCALE	DATE	DR	DWG	REV
4:1	5/25/2010	BLR	Q971009	F

Mouser Electronics

Authorized Distributor

Click to View Pricing, Inventory, Delivery & Lifecycle Information:

[E-Switch:](#)

[SS0750301F020P1A](#)