

RECOMMENDED PANEL MOUNTING

1
0 0 2
3 0 0 4
a-L-b (+)

SPST CONTACT CONFIGURATION

NOTES:

1. ALL DIMENSIONS IN MM [INCH]
2. GENERAL TOLERANCE: 0.0=±0.4
0.00=±0.25
3. RATINGS: 250VAC @1A, 2A, 4A, 5A

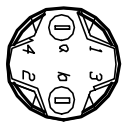
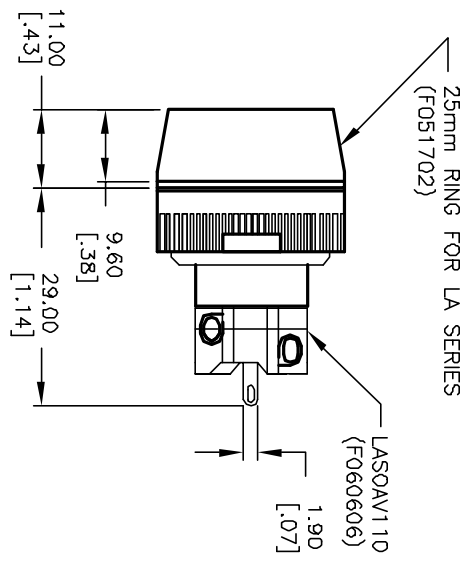
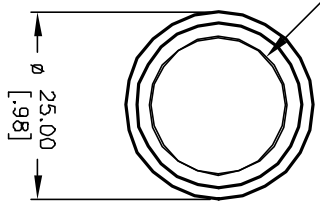

REV.	ECN No.	DESCRIPTION	DATE	CHK'D
A	1183	RELEASED FOR PRODUCTION	1/19/01	CJB

TITLE		SCALE		DATE	DR	DWG	REV
LAS DA V1 10 BLU		1:1		1/19/01	CJB	XF03194	A



THE INFORMATION CONTAINED IN THIS DOCUMENT IS PROPRIETARY TO E-SWITCH AND IS NOT TO BE COPIED OR TRANSMITTED

Mouser Electronics

Authorized Distributor

Click to View Pricing, Inventory, Delivery & Lifecycle Information:

[E-Switch:](#)

[LASOAV110BLU](#)