

THIS IS A C.A.D. GENERATED DRAWING  
DO NOT MAKE MANUAL REVISIONS TO MASTER.

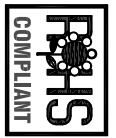

ISSUE NUMBER  
ORIGINAL

①

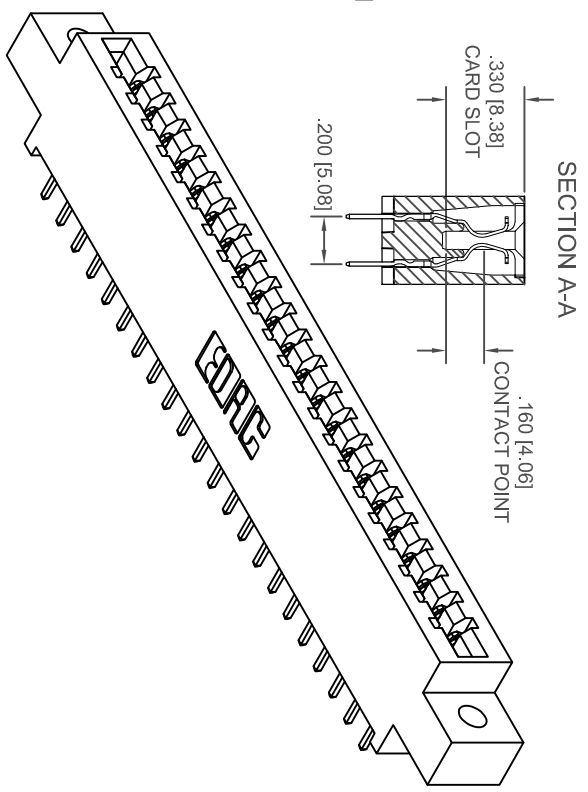
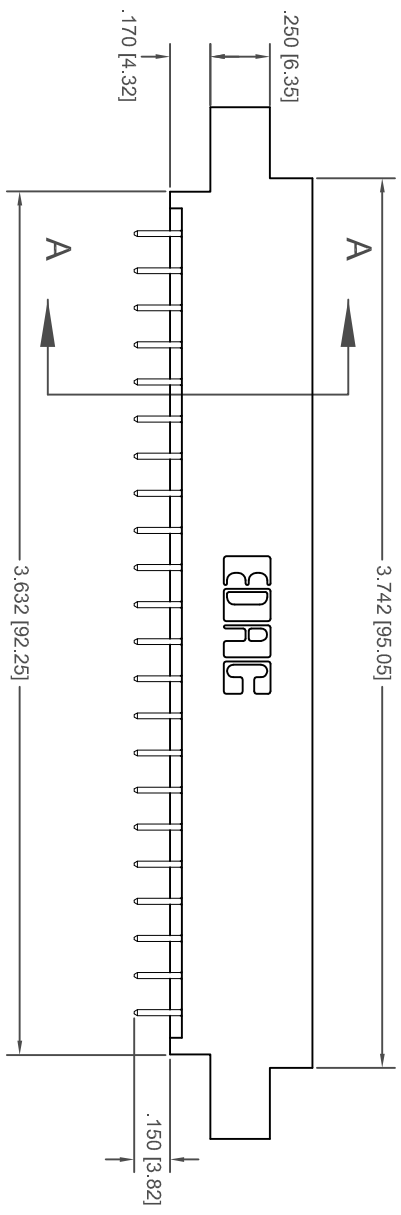
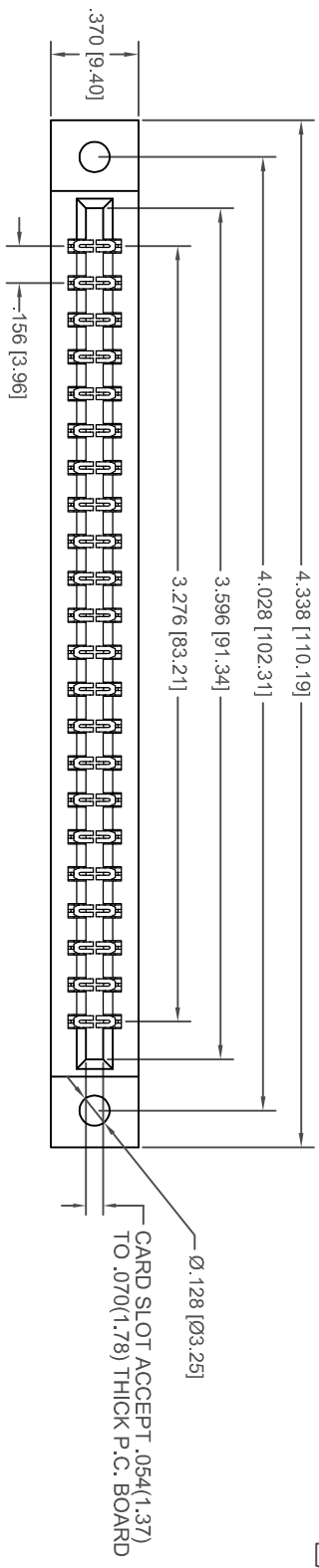

THIS SERIES FULLY CONFORMS TO THE  
EUROPEAN UNION DIRECTIVES  
2011/65/EU FOR ROHS COMPLIANCY.

- SPECIFICATIONS:**
- INSULATOR MATERIAL: THERMOPLASTIC POLYESTER, UL 94V-0, COLOR: (GREEN)
  - CONTACT MATERIAL: COPPER ALLOY
  - CONTACT PLATING: 15 MICRONS OF GOLD ON CONTACT AREA, TIN ON CONTACT TAIL, NICKEL UNDERPLATE.
  - CURRENT RATING: 3A CONTINUOUS
  - 2A CONTINUOUS @ 100°C AMBIENT TEMPERATURE
  - CONTACT RESISTANCE: 10 MILLIOHMS MAX
  - DIELECTRIC WITHSTANDING VOLTAGE: 1800 VAC rms, AT SEA LEVEL, BETWEEN ADJACENT CONTACTS.
  - INSULATION RESISTANCE: 5000 MEGOHMS MINIMUM.
  - OPERATING TEMPERATURE: -65°C TO +125°C
  - INSERTION FORCE: 16oz MAX. PER CONTACT WHEN TESTED WITH A .0700" THICK GAUGE.
  - WITHDRAWAL FORCE: 1oz MINIMUM PER CONTACT WHEN TESTED WITH A .0620" THICK GAUGE.

## 337 CARD EDGE CONNECTOR

**EDORC** EDAC INC  
TORONTO, ONTARIO  
CANADA  
YOUR CONNECTION TO QUALITY & SERVICE

THESE DRAWINGS AND SPECIFICATIONS  
ARE THE PROPERTY OF EDAC INC. AND  
SHALL NOT BE REPRODUCED OR COPIED  
OR USED AS THE BASIS FOR THE  
MANUFACTURE OR SALE OF APPARATUS  
WITHOUT WRITTEN PERMISSION.

ACAD REFERENCE NO. 337-044-521-300

DRAWN: R.STA.MONICA DATE: OCT.03/2014

PART NUMBER

**337-044-521-300**

DRAWING NUMBER

**337-044-521-300**

ISSUE

**1**

# Mouser Electronics

Authorized Distributor

Click to View Pricing, Inventory, Delivery & Lifecycle Information:

[EDAC:](#)

[337-044-521-300](tel:337-044-521-300)