

Small Plastic Package, Dual SPDT Analog Switch

Features

- ➔ CMOS Technology for Bus and Analog Applications
- ➔ Low On-Resistance: 0.45Ω
- ➔ Wide V_{DD} Range: 1.65V to 4.2V
- ➔ Rail-to-Rail Signal Range
- ➔ High Off Isolation: -83dB @ 100kHz
- ➔ Crosstalk Rejection Reduces Signal Distortion: -108dB @ 100kHz
- ➔ Break-Before-Make Switching
- ➔ Extended Industrial Temperature Range: -40°C to 85°C
- ➔ ESD protection : 4kV(HBM)
- ➔ Totally Lead-Free & Fully RoHS Compliant (Notes 1 & 2)
- ➔ Halogen and Antimony Free. "Green" Device (Note 3)
- ➔ Packaging (Pb-free & Green):
-10-pin UQFN (ZM), 1.4mm × 1.8mm

Block Diagram

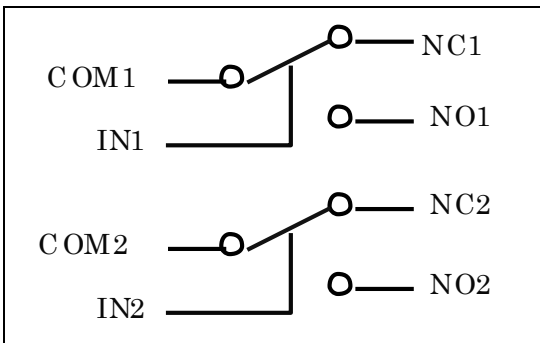

Pin Configuration (top view)

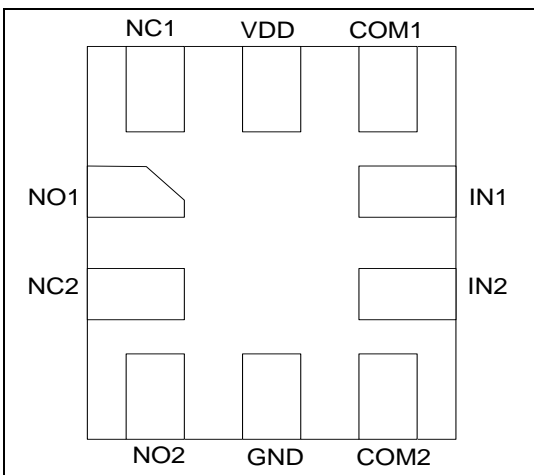

Notes:

1. No purposely added lead. Fully EU Directive 2002/95/EC (RoHS), 2011/65/EU (RoHS 2) & 2015/863/EU (RoHS 3) compliant.
2. See <https://www.diodes.com/quality/lead-free/> for more information about Diodes Incorporated's definitions of Halogen- and Antimony-free, "Green" and Lead-free.
3. Halogen- and Antimony-free "Green" products are defined as those which contain <900ppm bromine, <900ppm chlorine (<1500ppm total Br + Cl) and <1000ppm antimony compounds.

Description

PI3A2268 is a dual fast single-pole double throw (SPDT) CMOS switch. It can be used as an analog switch or as a low-delay bus switch. Specified over a wide operating power supply voltage, 1.65V to 4.2V, the PI3A2268 has an On-Resistance of 0.45Ω at +4.2V.

Break-before-make switching prevents both switches being enabled simultaneously. This eliminates signal disruption during switching.

Applications

- ➔ Cell Phones
- ➔ PDAs
- ➔ MP3 Players
- ➔ Portable Instrumentation
- ➔ Computer Peripherals
- ➔ Speaker Headset Switching
- ➔ Power Routing
- ➔ Relay Replacement
- ➔ Audio and Video Signal Routing
- ➔ PCMCIA Cards
- ➔ Modems

Pin Description

| Pin no | Name | Description |
|--------|-----------------|-----------------------------|
| 1 | NO1 | Data Port (Normally open) |
| 2 | NC2 | Data Port (Normally closed) |
| 3 | NO2 | Data Port (Normally open) |
| 4 | GND | Ground |
| 5 | COM2 | Common Output / Data Port |
| 6 | IN2 | Logic Control |
| 7 | IN1 | Logic Control |
| 8 | COM1 | Common Output / Data Port |
| 9 | V _{DD} | Positive Power Supply |
| 10 | NC1 | Data Port (Normally closed) |

Logic Function Table

| Logic Input (IN _x) | Function |
|--------------------------------|---|
| 0 | NC _x Connected to COM _x |
| 1 | NO _x Connected to COM _x |

Note: x = 1 or 2

Maximum Ratings

| | |
|---|-----------------|
| Storage Temperature..... | -65°C to +150°C |
| Ambient Temperature with Power Applied..... | -40°C to +85°C |
| Supply Voltage V_{DD} | -0.5V to +4.6V |
| Control Input Voltage V_{INx} | 0V to +4.6V |
| DC Input Voltage V_{INPUT} | -0.5V to +4.6V |
| Continuous Current NO_NC_COM_..... | ±300mA |
| Peak Current NO_NC_COM_ | |
| (pulsed at 1ms 50% duty cycle) | ±400mA |
| Peak Current NO_NC_COM_ | |
| (pulsed at 1ms 10% duty cycle) | ±500mA |
| ESD(HBM) | 4kV |

Note:

Stresses greater than those listed under MAXIMUM RATINGS may cause permanent damage to the device. This is a stress rating only and functional operation of the device at these or any other conditions above those indicated in the operational sections of this specification is not implied. Exposure to absolute maximum rating conditions for extended periods may affect reliability. The input and output negative voltage ratings may be exceeded if the input and output diode current ratings are observed. Control input must be held HIGH or LOW; it must not float.

Recommended Operating Conditions

| Symbol | Parameter | Conditions | Min. | Typ. | Max. | Unit |
|-------------|--------------------------|------------|------|------|----------|------|
| V_{DD} | Operating Voltage | - | 1.65 | - | 4.2 | V |
| V_{IN} | Control Input Voltage | - | 0 | - | V_{DD} | V |
| V_{INPUT} | Switch Input Voltage | - | -0.3 | - | 4.2 | V |
| T_A | Operating Temperature | - | -40 | 25 | 85 | °C |
| t_r, t_f | Input Rise and Fall Time | - | 0 | - | 10 | ns/V |

DC Electrical Characteristics

+3.0V Supply ($V_{DD} = 2.7V$ to $3.6V$, $V_{IH} = +1.6V$, $V_{IL} = +0.4V$, $T_A = -40°C$ to $85°C$, unless otherwise noted. Typical values are at $3.0V$ and $+25°C$.)

| Parameter | Symbol | Test Conditions | TEMP | Min. | Typ. | Max. | Units |
|--------------------------------------|---------------------------------------|--|---------------|------|------|----------|----------|
| ANALOG SWITCH | | | | | | | |
| Analog Signal Range | V_{NO}, V_{NC}, V_{COM} | - | -40°C to 85°C | 0 | - | V_{DD} | V |
| On-Resistance | R_{ON} | $V_{DD} = 2.7V, I_{COM} = 100mA, V_{NO}$ or $V_{NC} = 1V, \text{Test Circuit 1}$ | +25°C | - | 0.55 | 0.9 | Ω |
| | | | -40°C to 85°C | - | 0.55 | 1 | |
| On-Resistance Match Between Channels | ΔR_{ON} | $V_{DD} = 2.7V, I_{COM} = 100mA, V_{NO}$ or $V_{NC} = 1V, \text{Test Circuit 1}$ | +25°C | - | 0.05 | 0.22 | Ω |
| | | | -40°C to 85°C | - | 0.05 | 0.25 | |
| On-Resistance Flatness | R_{ONF} | $V_{DD} = 2.7V, I_{COM} = 100mA, V_{NO}$ or $V_{NC} = 1V, 2.5V, \text{Test Circuit 1}$ | +25°C | - | 0.1 | 0.22 | Ω |
| | | | -40°C to 85°C | - | 0.1 | 0.26 | |
| Source Off Leakage Current | $I_{OFF(NO)}$ or $I_{OFF(NC)}$ | $V_{DD} = 3.6V, V_{NO}$ or $V_{NC} = 3.3V/0.3V, V_{COM} = 0.3V/3.3V$ | -40°C to 85°C | - | - | 1 | μA |
| Channel On Leakage Current | $I_{NC(ON)}, I_{NO(ON)}, I_{COM(ON)}$ | $V_{DD} = 3.6V, V_{NO}$ or $V_{NC} = 3V/0.3V, V_{COM} = 3V/0.3V, \text{ or floating}$ | -40°C to 85°C | - | - | 1 | |
| DIGITAL INPUTS | | | | | | | |
| Input Logic High | V_{IH} | - | -40°C to 85°C | 1.2 | - | - | V |
| Input Logic Low | V_{IL} | - | -40°C to 85°C | - | - | 0.5 | |
| IN Input Leakage Current | I_{IN} | $V_{DD} = 2.7V, V_{IN} = 0$ or $2.7V$ | -40°C to 85°C | - | - | 1 | μA |
| DYNAMIC CHARACTERISTICS | | | | | | | |
| Turn-On Time | t_{ON} | $V_{IH} = 1.5V, V_{IL} = 0V, \text{ See Test Circuit Figure 2.}$ | +25°C | - | 15 | - | ns |
| Turn-Off Time | t_{OFF} | $V_{IH} = 1.5V, V_{IL} = 0V, \text{ See Test Circuit Figure 2.}$ | +25°C | - | 20 | - | ns |
| Break-Before-Make Delay | t_D | $V_{IH} = 1.5V, V_{IL} = 0V, \text{ See Test Circuit Figure 3.}$ | +25°C | - | 10 | - | ns |
| COM-NC/NO and | O_{ISO} | $V_{BIAS} = 1.5V, V_{IN} = 0dBm, 100kHz$ | +25°C | - | -81 | - | dB |

| | | | | | | | | |
|---|-------------|---|--------|-------|---|------|---|-----|
| NC-NO Isolations | | $V_{IH}=1.5V, V_{IL}=0V$. See Test Circuit Figure 4 & Figure 5. | 1MHz | +25°C | - | -61 | - | |
| | | | 10MHz | +25°C | - | -39 | - | |
| Channel-to-Channel Crosstalk | X_{TALKD} | $V_{BIAS} = 1.5V, V_{DD}=0dBm, V_{IH}=1.5V, V_{IL}=0V$ See Test Circuit Figure 6. | 100kHz | +25°C | - | -108 | - | dB |
| | | | 1MHz | +25°C | - | -110 | - | |
| | | | 10MHz | +25°C | - | -90 | - | |
| 3dB Bandwidth | f_{3dB} | $V_{BIAS} = 1.5V, V_{IN}=0dBm, V_{IH}=1.5V, V_{IL}=0V$. See Test Circuit Figure 7. | | +25°C | - | 79 | - | MHz |
| Charge Injection Select Input to Common I/O | Q | $V_{IN} = GND, R_S = 0, C_L = 1nF, V_{IH}=1.5V, V_{IL}=0V$ See Test Circuit Figure 8. | | +25°C | - | 35 | - | pC |

+4.2V Supply ($V_{DD} = 4.2V, T_A = -40^\circ C$ to $85^\circ C$, unless otherwise noted. Typical values are at 4.2V and +25°C.)

| Parameter | Symbol | Test Conditions | TEMP | Min. | Typ. | Max. | Units | |
|--------------------------------------|---------------------------------------|--|---------------|-------|------|----------|----------|-----|
| ANALOG SWITCH | | | | | | | | |
| Analog Signal Range | V_{NO}, V_{NC}, V_{COM} | - | -40°C to 85°C | 0 | - | V_{DD} | V | |
| On-Resistance | R_{ON} | $V_{DD} = 4.2V, I_{COM} = 100mA, V_{NO}$ or $V_{NC} = 1V$, Test Circuit 1 | +25°C | - | 0.45 | 0.75 | Ω | |
| | | | -40°C to 85°C | - | 0.45 | 0.85 | | |
| On-Resistance Match Between Channels | ΔR_{ON} | $V_{DD} = 4.2V, I_{COM} = 100mA, V_{NO}$ or $V_{NC} = 1V$, Test Circuit 1 | +25°C | - | 0.05 | 0.18 | Ω | |
| | | | -40°C to 85°C | - | 0.05 | 0.23 | | |
| On-Resistance Flatness | R_{ONF} | $V_{DD} = 4.2V, I_{COM} = 100mA, V_{NO}$ or $V_{NC} = 1V, 2.5V$, Test Circuit 1 | +25°C | - | 0.1 | 0.22 | Ω | |
| | | | -40°C to 85°C | - | 0.1 | 0.26 | | |
| Source Off Leakage Current | $I_{OFF(NO)}$ or $I_{OFF(NC)}$ | $V_{DD} = 4.2V, V_{NO}$ or $V_{NC} = 3.3V/0.3V, V_{COM} = 0.3V/3V$ | -40°C to 85°C | - | - | 1 | μA | |
| Channel On Leakage Current | $I_{NC(ON)}, I_{NO(ON)}, I_{COM(ON)}$ | $V_{DD} = 4.2V, V_{NO}$ or $V_{NC} = 3V/0.3V, V_{COM} = 3V/0.3V$, or floating | -40°C to 85°C | - | - | 1 | | |
| DIGITAL INPUTS | | | | | | | | |
| Input Logic High | V_{IH} | - | -40°C to 85°C | 1.2 | - | - | V | |
| Input Logic Low | V_{IL} | - | -40°C to 85°C | - | - | 0.5 | | |
| IN Input Leakage Current | I_{IN} | $V_{DD} = 4.2V, V_{IN}=0$ or 4.2V | -40°C to 85°C | - | - | 1 | μA | |
| DYNAMIC CHARACTERISTICS | | | | | | | | |
| Turn-On Time | t_{ON} | $V_{IH}=3V, V_{IL}=0V$, See Test Circuit Figure 2. | +25°C | - | 13 | - | ns | |
| Turn-Off Time | t_{OFF} | $V_{IH}=3V, V_{IL}=0V$, See Test Circuit Figure 2. | +25°C | - | 12 | - | ns | |
| Break-Before-Make Delay | t_D | $V_{IH}=3V, V_{IL}=0V$, See Test Circuit Figure 3. | +25°C | - | 8 | - | ns | |
| COM-NC/NO and NC-NO Isolations | O_{ISO} | $V_{BIAS} = 2.1V, V_{IN}=0dBm, V_{IH}=3V, V_{IL}=0V$. See Test Circuit Figure 4 & Figure 5. | 100kHz | +25°C | - | -83 | - | dB |
| | | | 1MHz | +25°C | - | -61 | - | |
| | | | 10MHz | +25°C | - | -39 | - | |
| Channel-to-channel Crosstalk | X_{TALK} | $V_{BIAS} = 2.1V, V_{IN}=0dBm, V_{IH}=3V, V_{IL}=0V$ See Test Circuit Figure 6. | 100kHz | +25°C | - | -108 | - | dB |
| | | | 1MHz | +25°C | - | -110 | - | |
| | | | 10MHz | +25°C | - | -90 | - | |
| 3dB Bandwidth | f_{3dB} | $V_{BIAS} = 2.1V, V_{IN}=0dBm, V_{IH}=3V, V_{IL}=0V$. See Test Circuit Figure 7. | | +25°C | - | 84 | - | MHz |

| | | | | | | | |
|---|----------|--|---------------|------|----|-----|----|
| Charge Injection Select Input to Common I/O | Q | $V_{IN} = GND, R_S = 0, C_L = 1nF,$ $V_{IH}=3V, V_{IL}=0V$ <i>See Test Circuit Figure 8.</i> | +25°C | - | 50 | - | pC |
| POWER REQUIREMENTS | | | | | | | |
| Power Supply Range | V_{DD} | - | -40°C to 85°C | 1.65 | - | 4.2 | V |
| Power Supply Current | I_{CC} | $V_{DD}=4.2V, V_{IN}=0V$ or V_{DD} | -40°C to 85°C | - | - | 1 | μA |

Capacitance

| Parameter | Symbol | Test Conditions | Min. | Typ. | Max. | Units |
|--------------------|---------------|---|------|------|------|-------|
| NC Off Capacitance | $C_{NC(OFF)}$ | $f = 1MHz, \text{ See Test Circuit Figure 9.}$ | - | 20 | - | pF |
| NO Off Capacitance | $C_{NO(OFF)}$ | $f = 1MHz, \text{ See Test Circuit Figure 9.}$ | - | 20 | - | |
| NC On Capacitance | $C_{NC(ON)}$ | $f = 1MHz, \text{ See Test Circuit Figure 10.}$ | - | 55 | - | |
| NO On Capacitance | $C_{NO(ON)}$ | $f = 1MHz, \text{ See Test Circuit Figure 10.}$ | - | 55 | - | |

Test Circuits and Timing Diagrams

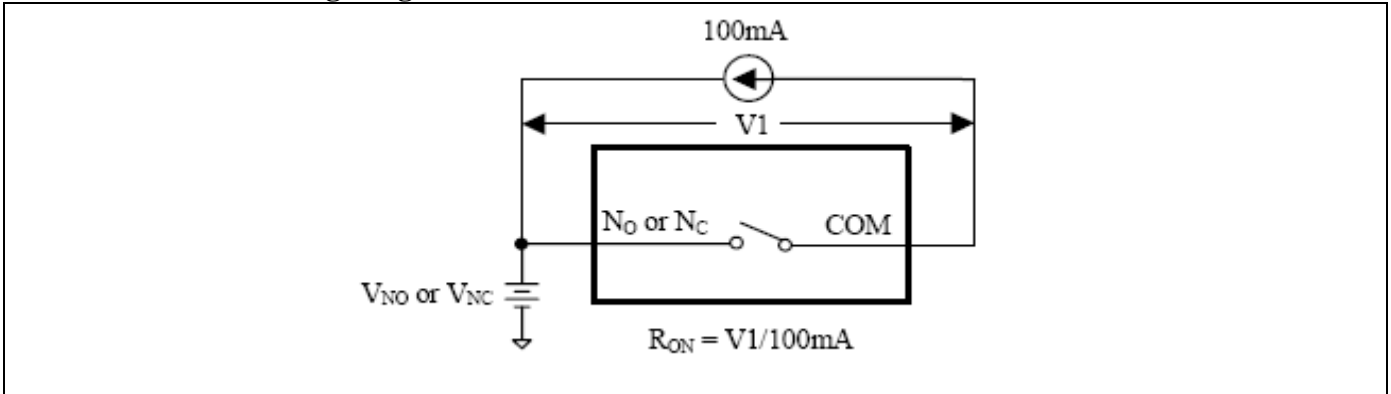

Figure 1. On Resistance

Notes:

1. Unused input (NC or NO) must be grounded.

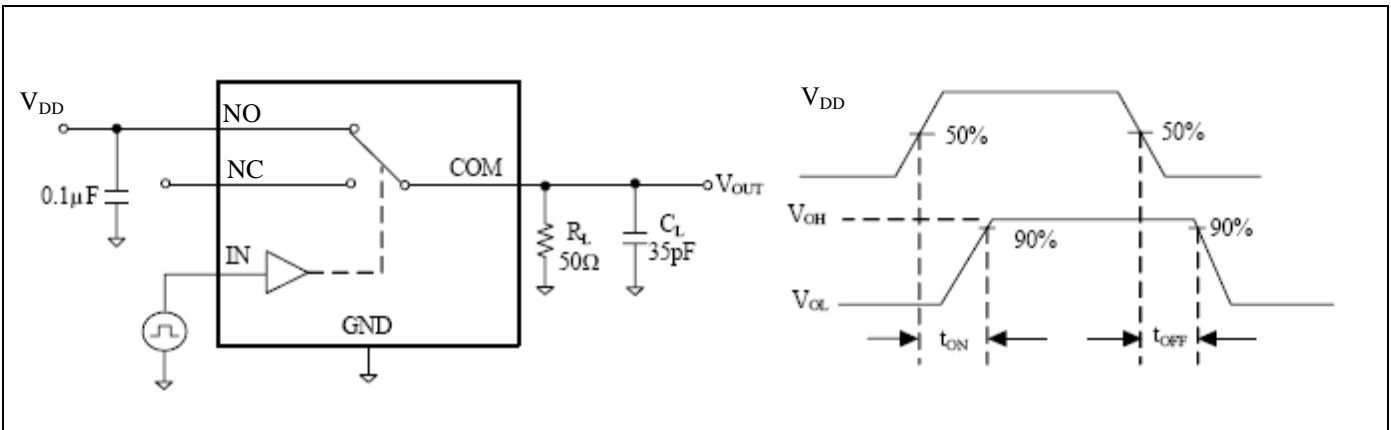

Figure 2. Switching Times

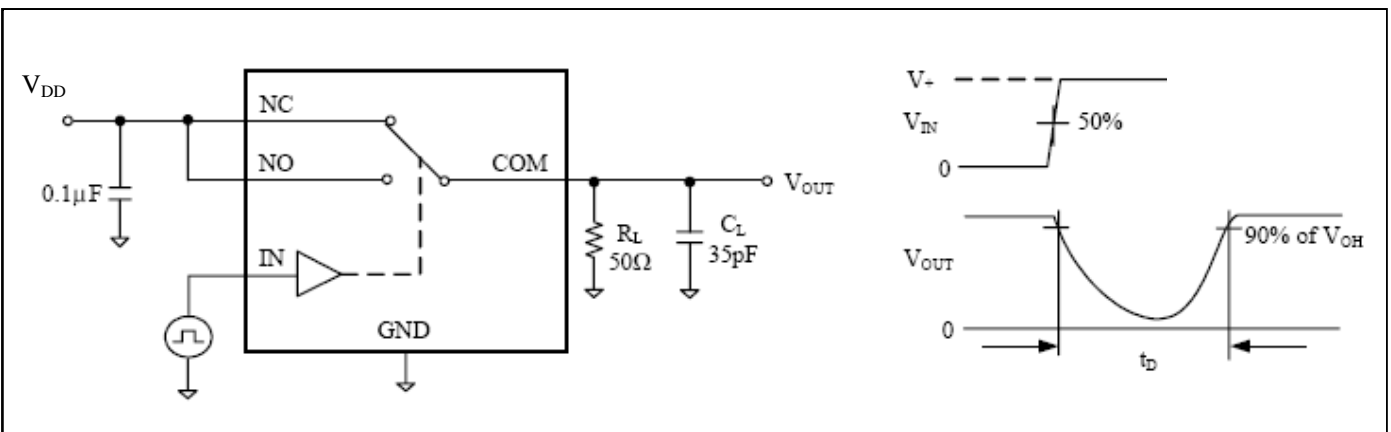

Figure 3. Break Before Make Interval Timing

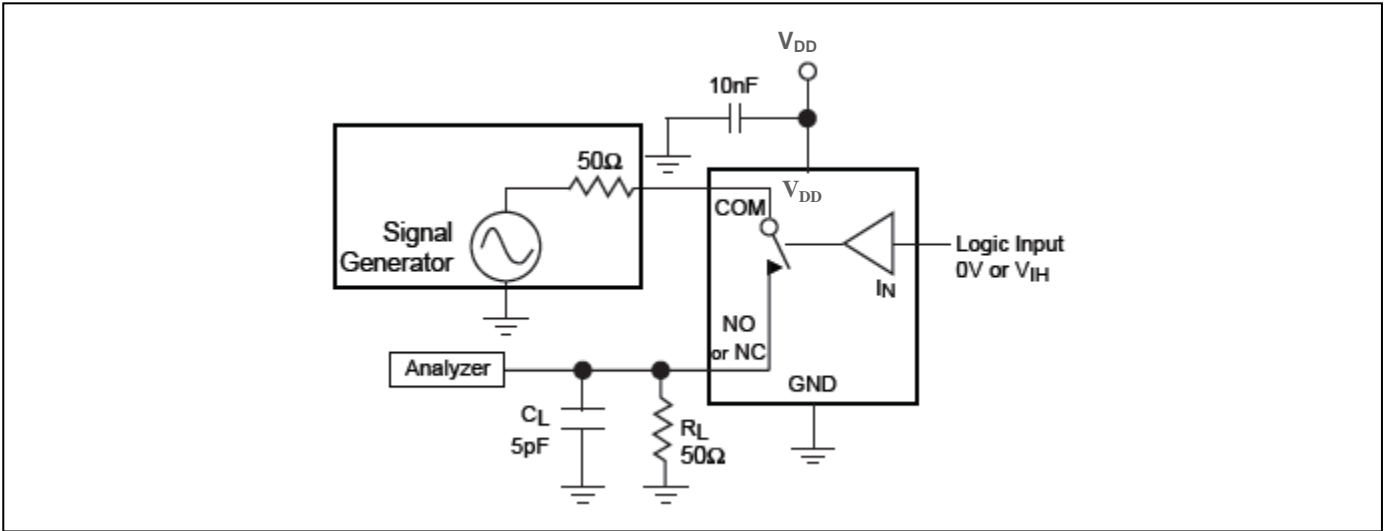

Figure 4. COM-NC/NO Isolation

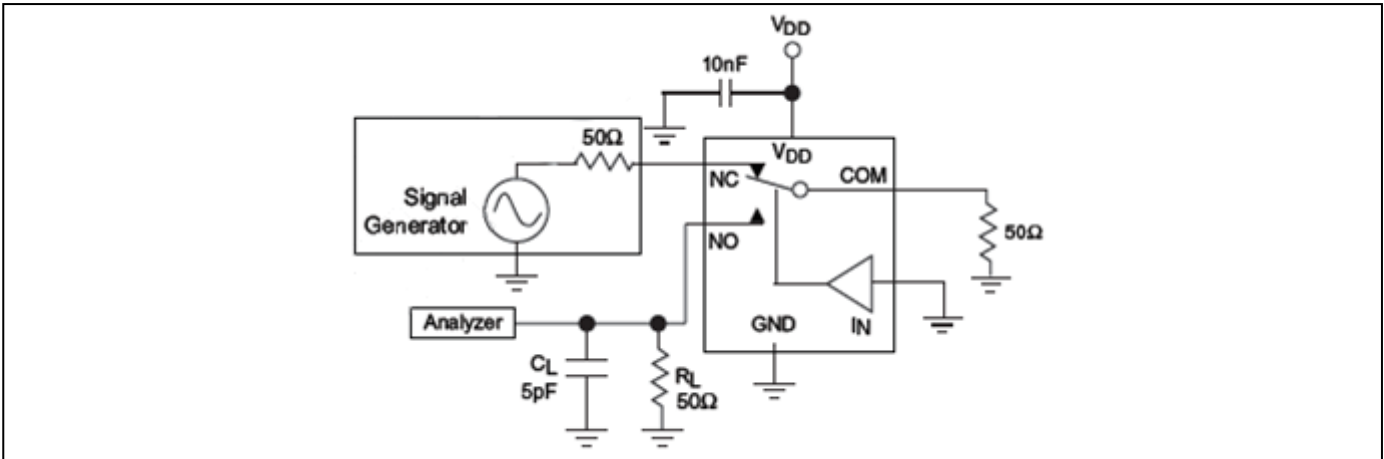

Figure 5. NC-NO Isolation

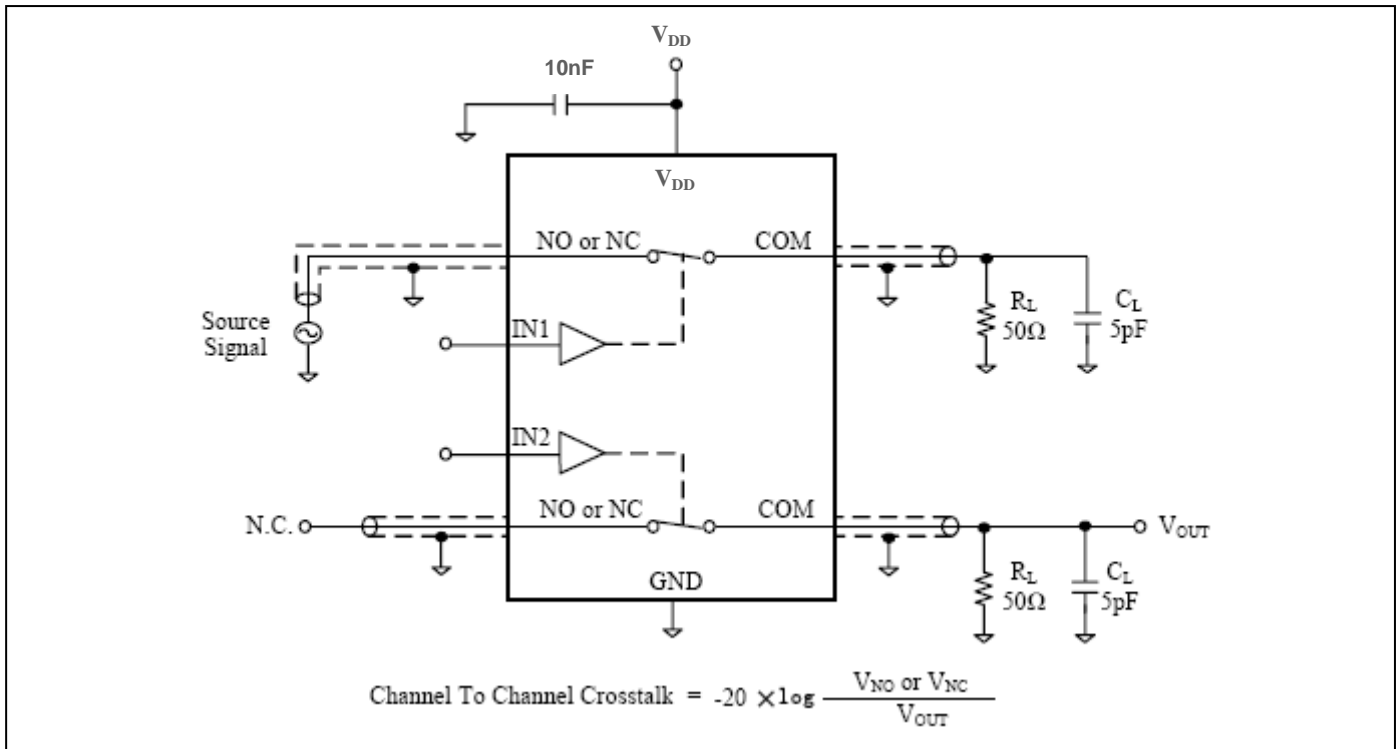

Figure 6. Channel-to-Channel Crosstalk

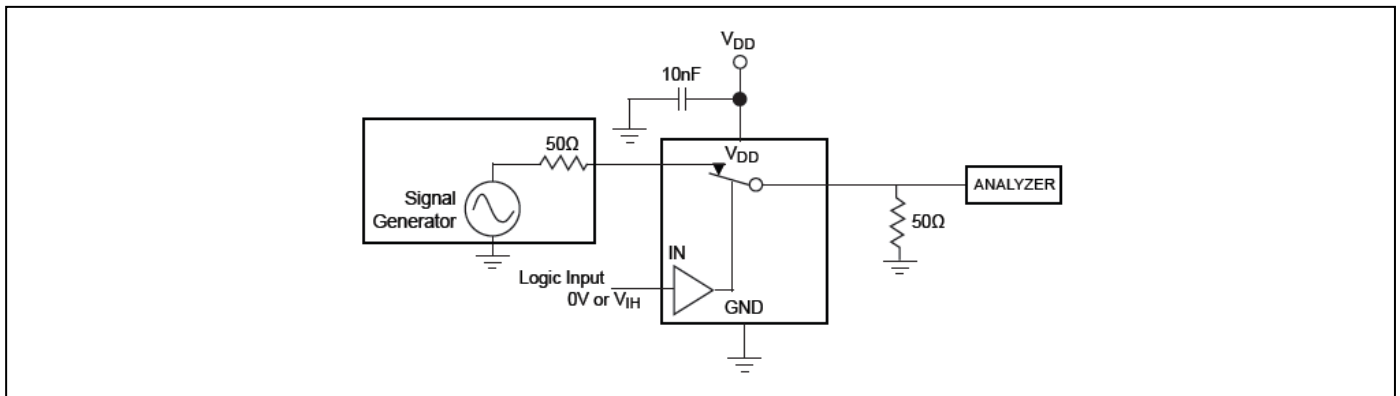

Figure 7. Bandwidth

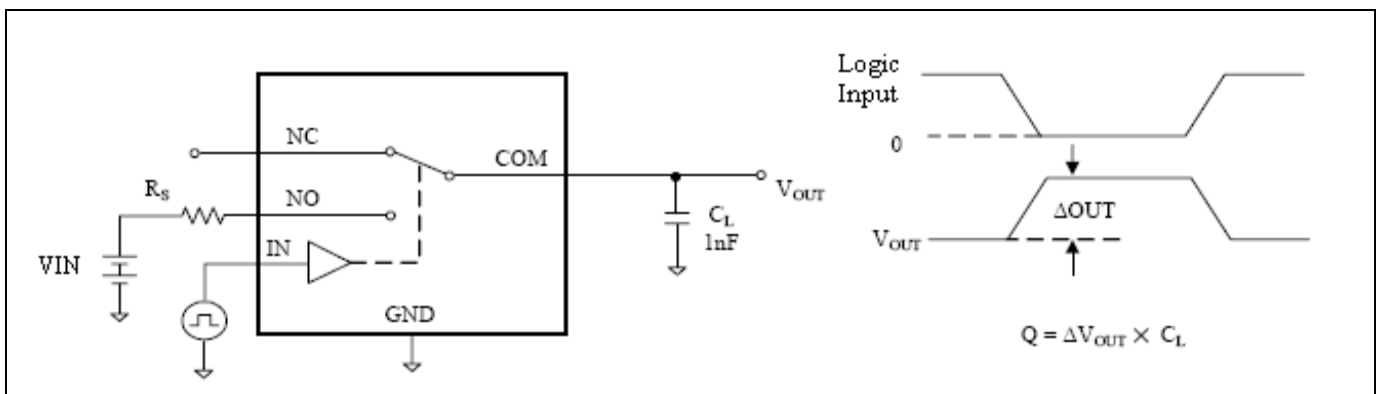

Figure 8. Charge Injection

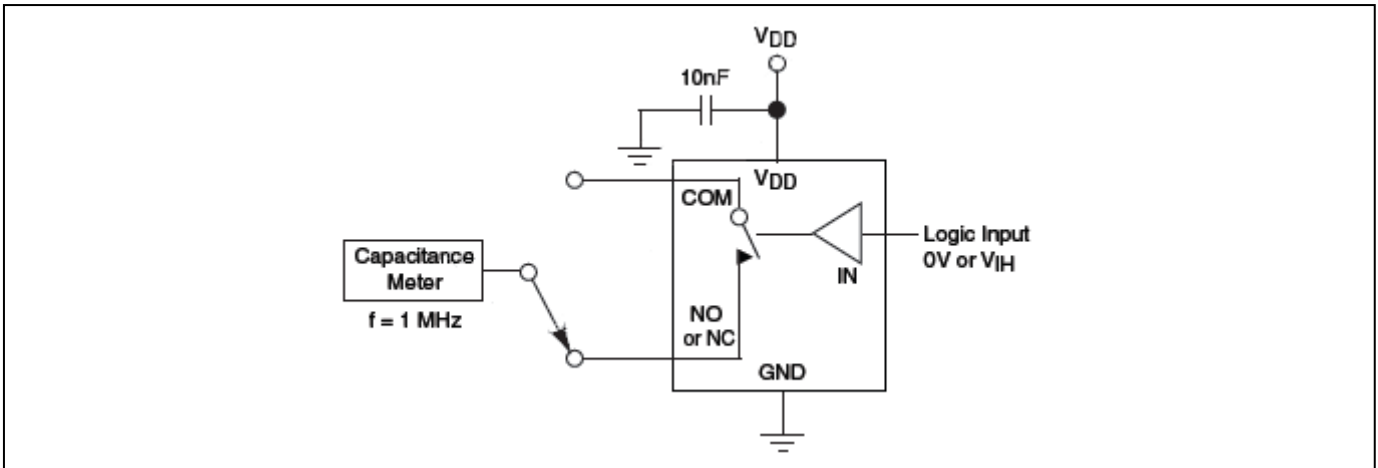

Figure 9. Channel Off Capacitance

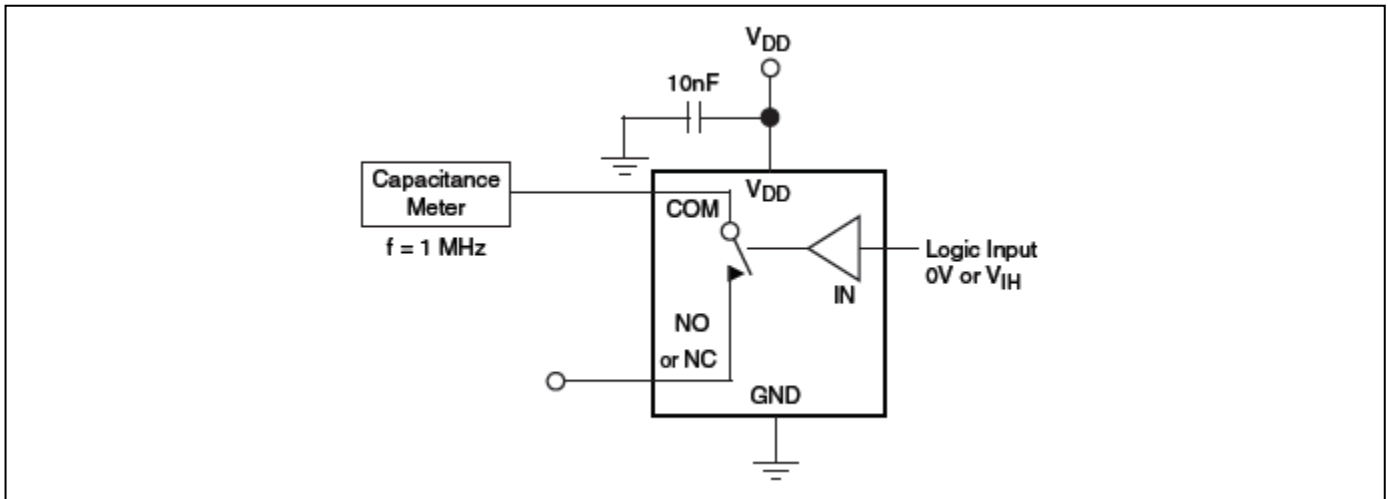
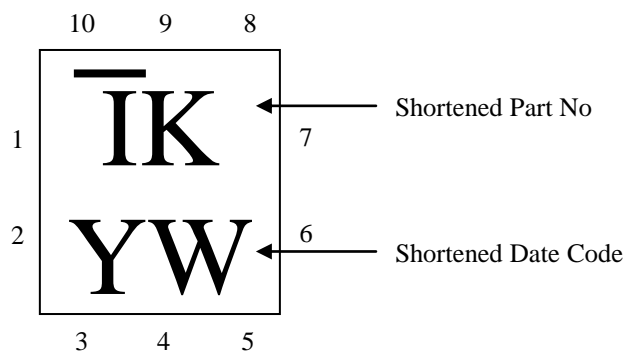

Figure 10. Channel On Capacitance

Part Marking

ZM Package



Packaging Mechanical: 10-UQFN (ZM10)

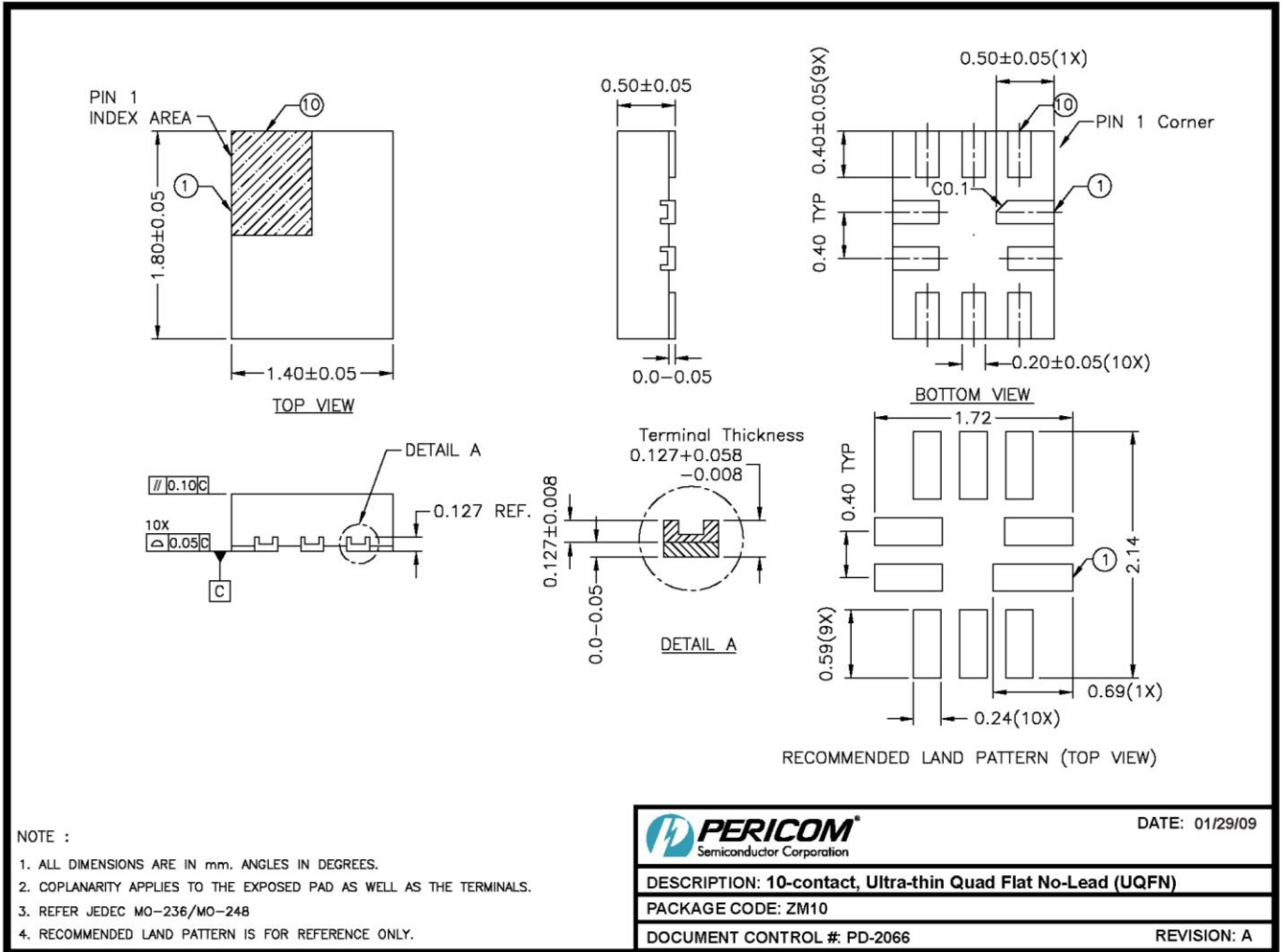

09-0072

For latest package information:

Please see <http://www.diodes.com/design/support/packaging/pericom-packaging/packaging-mechanicals-and-thermal-characteristics/>.

Ordering Information

| Part Number | Packaging Code | Description |
|--------------|----------------|---|
| PI3A2268ZMEX | ZM | 10-contact, Ultra-thin Quad Flat No-Lead (UQFN) |

Notes:

- No purposely added lead. Fully EU Directive 2002/95/EC (RoHS), 2011/65/EU (RoHS 2) & 2015/863/EU (RoHS 3) compliant.
- See <https://www.diodes.com/quality/lead-free/> for more information about Diodes Incorporated's definitions of Halogen- and Antimony-free, "Green" and Lead free.
- Halogen- and Antimony-free "Green" products are defined as those which contain <900ppm bromine, <900ppm chlorine (<1500ppm total Br + Cl) and <1000ppm antimony compounds.
- E = Pb-free and Green
- X suffix = Tape/Reel

IMPORTANT NOTICE

DIODES INCORPORATED MAKES NO WARRANTY OF ANY KIND, EXPRESS OR IMPLIED, WITH REGARDS TO THIS DOCUMENT, INCLUDING, BUT NOT LIMITED TO, THE IMPLIED WARRANTIES OF MERCHANTABILITY AND FITNESS FOR A PARTICULAR PURPOSE (AND THEIR EQUIVALENTS UNDER THE LAWS OF ANY JURISDICTION).

Diodes Incorporated and its subsidiaries reserve the right to make modifications, enhancements, improvements, corrections or other changes without further notice to this document and any product described herein. Diodes Incorporated does not assume any liability arising out of the application or use of this document or any product described herein; neither does Diodes Incorporated convey any license under its patent or trademark rights, nor the rights of others. Any Customer or user of this document or products described herein in such applications shall assume all risks of such use and will agree to hold Diodes Incorporated and all the companies whose products are represented on Diodes Incorporated website, harmless against all damages.

Diodes Incorporated does not warrant or accept any liability whatsoever in respect of any products purchased through unauthorized sales channel.

Should Customers purchase or use Diodes Incorporated products for any unintended or unauthorized application, Customers shall indemnify and hold Diodes Incorporated and its representatives harmless against all claims, damages, expenses, and attorney fees arising out of, directly or indirectly, any claim of personal injury or death associated with such unintended or unauthorized application.

Products described herein may be covered by one or more United States, international or foreign patents pending. Product names and markings noted herein may also be covered by one or more United States, international or foreign trademarks.

This document is written in English but may be translated into multiple languages for reference. Only the English version of this document is the final and determinative format released by Diodes Incorporated.

LIFE SUPPORT

Diodes Incorporated products are specifically not authorized for use as critical components in life support devices or systems without the express written approval of the Chief Executive Officer of Diodes Incorporated. As used herein:

- A. Life support devices or systems are devices or systems which:
1. are intended to implant into the body, or
 2. support or sustain life and whose failure to perform when properly used in accordance with instructions for use provided in the labeling can be reasonably expected to result in significant injury to the user.
- B. A critical component is any component in a life support device or system whose failure to perform can be reasonably expected to cause the failure of the life support device or to affect its safety or effectiveness.

Customers represent that they have all necessary expertise in the safety and regulatory ramifications of their life support devices or systems, and acknowledge and agree that they are solely responsible for all legal, regulatory and safety-related requirements concerning their products and any use of Diodes Incorporated products in such safety-critical, life support devices or systems, notwithstanding any devices- or systems-related information or support that may be provided by Diodes Incorporated. Further, Customers must fully indemnify Diodes Incorporated and its representatives against any damages arising out of the use of Diodes Incorporated products in such safety-critical, life support devices or systems.

Copyright © 2018, Diodes Incorporated
www.diodes.com

Mouser Electronics

Authorized Distributor

Click to View Pricing, Inventory, Delivery & Lifecycle Information:

[Diodes Incorporated:](#)

[PI3A2268ZMEX](#)