

General Description

The AL8841QEV1-EMC, shown in Figure 1, is a double-sided evaluation board for the AL8841Q step-down, or “buck”, LED driver with internal switch in the TSOT25 package. The evaluation board is preset to drive 1000mA into a single LED or multiple LEDs, the maximum number of which depends on their total forward voltage drop and the supply voltage.

This guide contains rich information for users to take advantage of. A bill of materials that describes the parts used on this board is included. A schematic and PCB layout are also included, along with measured system performance characteristics and test waveforms. These materials can be used as a reference design for your products to improve time to market.

Key Features

- AEC-Q100 Grade 1 Qualified
- Wide Input Voltage Range: 5V to 40V
- Constant Current Mode PWM Controller
- PWM/Analog Dimming Mode
- Up to 1MHz Switching Frequency
- Built-in Comprehensive Protections
 - Undervoltage Lock Out (UVLO)
 - Overvoltage Protection(OVP)
 - Overcurrent Protection(OCP)
 - Overtemperature Protection (OTP)
 - LED Open Protection
 - Output Short Protection
- Low System BOM Cost
- **Totally Lead-Free & Fully RoHS Compliant (Notes 1 & 2)**
- **Halogen and Antimony Free. “Green” Device (Note 3)**
- **The AL8841Q is suitable for automotive applications requiring specific change control; this part is AEC-Q100 qualified, PPAP capable, and manufactured in IATF 16949 certified facilities.**
<https://www.diodes.com/quality/product-definitions/>

Applications

- Head up displays (HUD)
- Auto backlight displays

Specifications

Parameter	Value
Input Voltage	5V~40Vdc
Output Current	1A
Output Voltage	1~10LEDs
Efficiency	>82%
Dimension	74mm*46mm*10mm
RoHS Compliance	Yes

1. No purposely added lead. FullyEU Directive 2002/95/EC (RoHS), 2011/65/EU (RoHS 2) & 2015/863/EU (RoHS 3) compliant.
2. See <https://www.diodes.com/quality/lead-free/> for more information about Diodes Incorporated's definitions of Halogen- and Antimony-free, "Green" and Lead-free.
3. Halogen- and Antimony-free "Green" products are defined as those which contain <900ppm bromine, <900ppm chlorine (<1500ppm total Br + Cl) and <1000ppm antimony compounds.

Evaluation Board



Figure 1: Top View

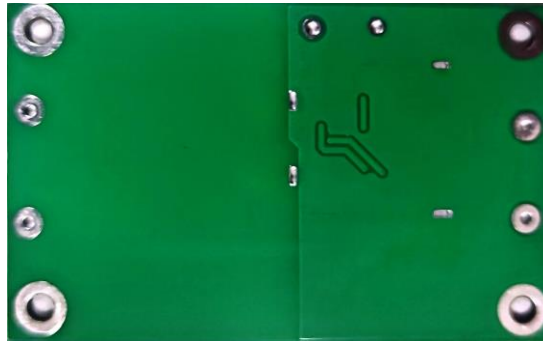

Figure 2: Bottom View

Connection Instructions

- DC Positive Input: Red Test Point (BAR+)
- DC Negative Input: White Test Point (BAR-)
- PWM Signal Input: White Test Point (DIM)
- GND Signal Input: Black Test Point (GND)
- Positive Output: Red Test Point (LEDA)
- Negative Output: Black Test Point (LEDK)

Board Layout

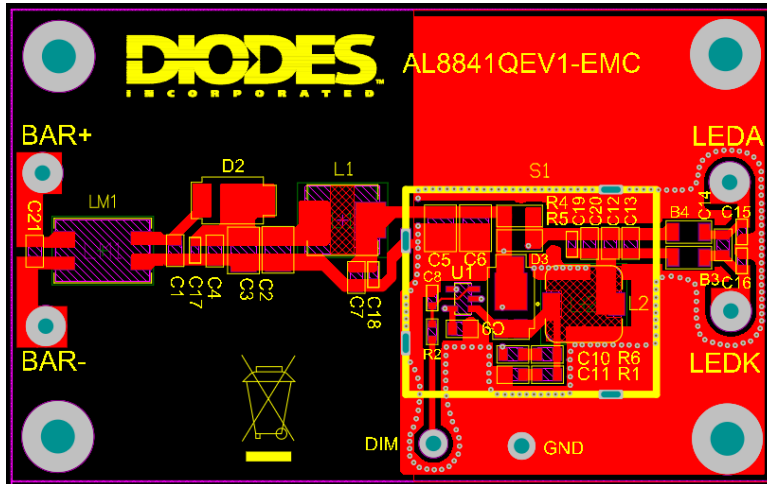

Figure 3: PCB Layout Top View

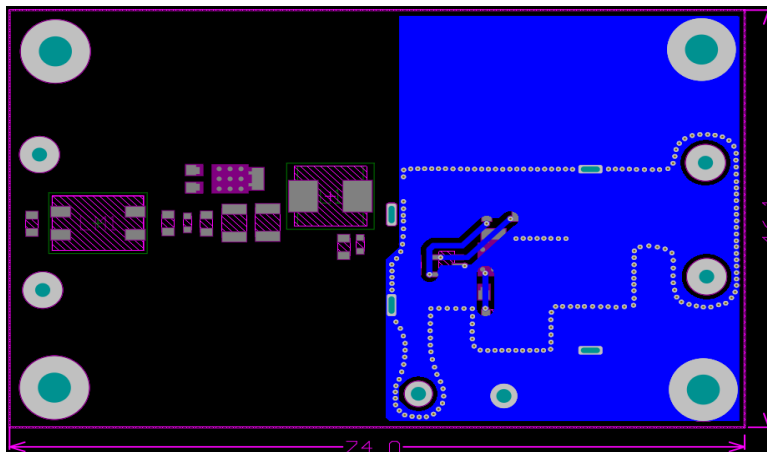

Figure 4: PCB Layout Bottom View

Quick Start Guide

1. Ensure that the power supply and the PWM signal are switched OFF or disconnected.
2. Connect the LED power supply to the test point "BAR+" and "BAR-".
3. Connect the LED string anode to the test point "LEDA".
4. Connect the LED string cathode to the test point "LEDK".
5. Turn on the LED power supply. The LED string will light on and output the preset current.
6. Dimming mode: Connect the PWM/Analog signal to "DIM" and "GND".

Evaluation Board Schematic

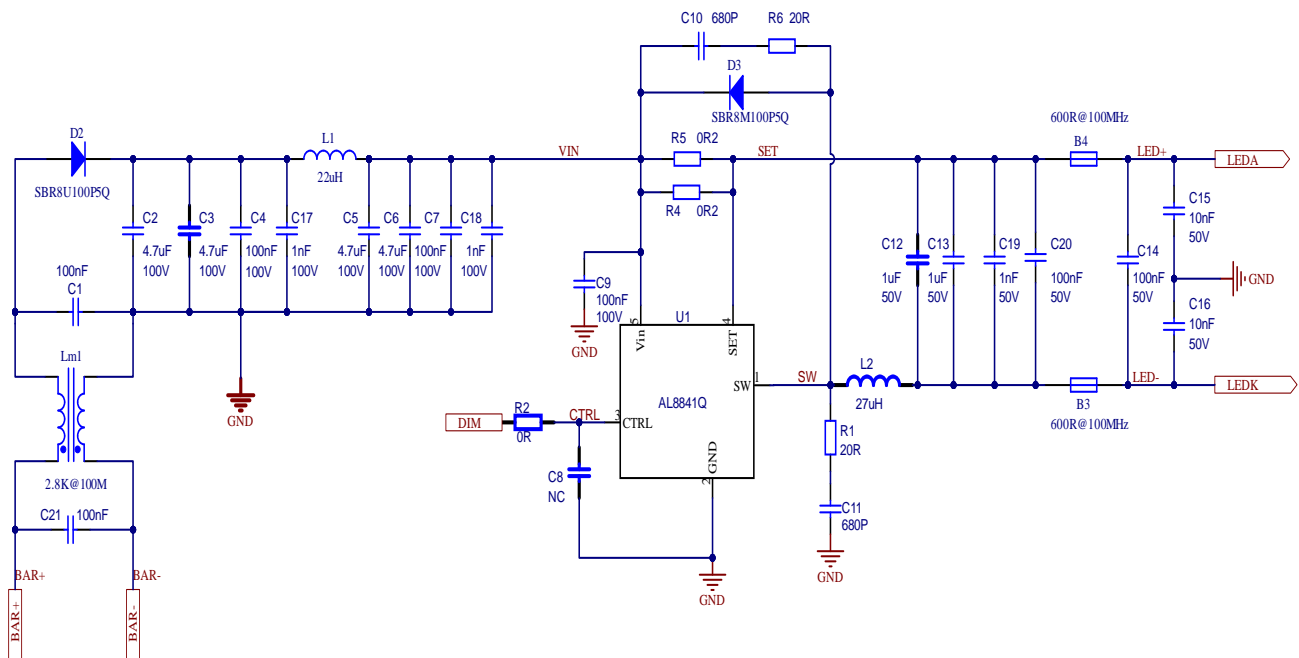

Figure 5: Schematic Circuit

Bill of Materials

NO.	Location	Description	Package	Quantity
1	R2	Resistor, SMT, 0 ohm, 0603, 5%	0603	1
2	R4, R5	Resistor, SMT, 0.2 ohm, 1206, 1%	1206	2
3	R1, R6	Resistor, SMT, 20 ohm, 0805, 5%	0805	2
4	C2, C3, C5, C6	Cap, Cer, GCJ32DC72A475KE01L, 4.7uF, 100V, X7S, 1210, -55°C~125°C, AEC-Q200, Murata	1210	4
5	C1, C4, C7, C9, C21	Cap, Cer, CGA4J2X7R2A104K125AA, 100nF, 100V, X7R, 0805, -55°C~125°C, AEC-Q200, TDK	0805	5
6	C15, C16	Cap, Cer, CGA3E2X7R2A103K080AA, 10nF, 100V, X7R, 0603, -55°C~125°C, AEC-Q200, TDK	0603	2
7	C17, C18	Cap, Cer, CGA3E2X7R2A102K080AA, 1nF, 100V, X7R, 0603, -55°C~125°C, AEC-Q200, TDK	0603	2
8	C10, C11	Cap, Cer, CL21C681JCC1PNC, 680pF, 100V, NP0, 0805, -55°C~125°C, AEC-Q200, Samsung	0805	2
9	C12, C13	Cap, Cer, CGA4J3X7R1H105K125AB, 1uF, 50V, X7R, 0805, -55°C~125°C, AEC-Q200, TDK	0805	2
10	C14, C20	Cap, Cer, CGA4J2X8R1H104K125AA, 100nF, 50V, X8R, 0805, -55°C~150°C, AEC-Q200, TDK	0805	2
11	C19	Cap, Cer, GCD188R71H102KA01D, 1nF, 50V, X7R, 0603, -55°C~125°C, AEC-Q200, Murata	0603	1
12	U1	IC, AL8841QWT-7, AEC-Q100 Qualified, DIODES	TSOT25	1
13	B3, B4	78279221601, 600ohm@100MHz, AEC-Q200, Würth Elektronik	1206	2
14	L1	74437349220, 22uH, Isat=2.1A, 7.3x6.6x4.8mm, AEC-Q200, Würth Elektronik	SMT	1
15	L2	7447779127, 27uH, Isat=1.24A, 7.3x7.3x4.5mm, AEC-Q200, Würth Elektronik	SMT	1
16	LM1	744228, CM 25uH, 1000mA, 2.8K@100MHz, AEC-Q200, Würth Elektronik	SMT	1
17	D2, D3	Diode, SBR8M100P5Q-13, 8A, 100V, AEC-Q101 Qualified, DIODES	POWER DI5	2
18	DIM	Connector, Orange color	DIP	1
19	LEDK, GND	Connector, Black color	DIP	2
20	BAR-	Connector, White color	DIP	1
21	LEDA, BAR+	Connector, Red color	DIP	2
22	S1	Shielding cover (IFG-2024) 20mmx24.5mmx10mm	DIP	1

System Performance

The AL8841Q evaluation board has excellent system performance. With a very low BOM cost, the system can achieve high efficiency and good dimming linearity. To enhance reliability, the AL8841Q also integrates comprehensive protections.

System Efficiency

Figure 6 shows the efficiency curve, which is measured with 12V DC input and 2*LED as the load.

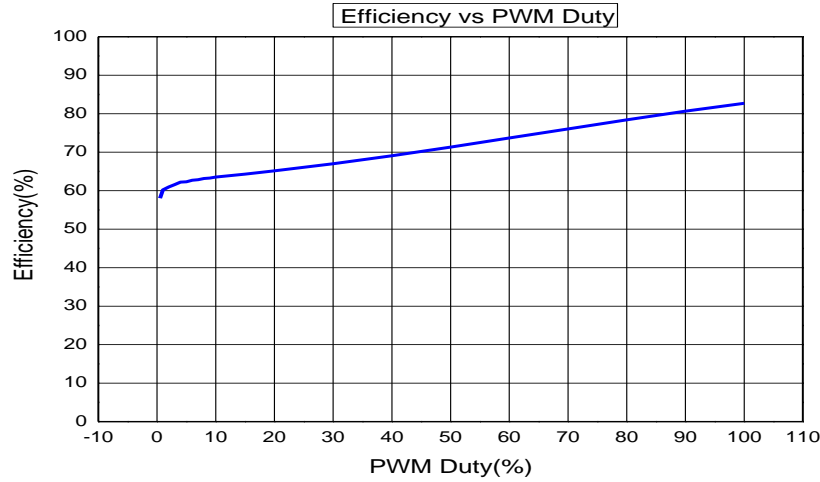

Figure 6: Efficiency vs PWM Duty

System Line Regulation

Figure 7 shows the line regulation, which is measured with 12~40V DC input and 2*LED as the load.

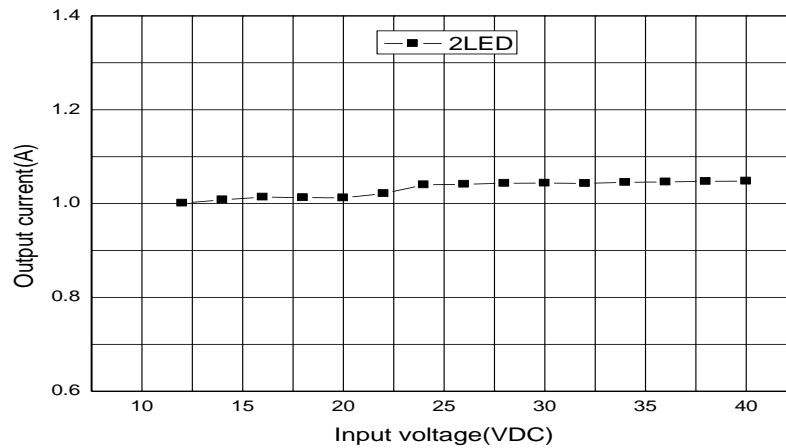

Figure 7: Efficiency vs PWM Duty

Dimming Performance

The AL8841Q supports PWM dimming with frequencies ranging from 100Hz to 20 kHz. Figure 8 shows the dimming curve with measured data. The AL8841Q dimming linearity is good, with PWM duty from 1% to 100%.

Figure 8: LED Current vs PWM Duty

Figure 9: LED Current vs DIM Pin Voltage

LED Open Protection

The AL8841Q has, by default, open LED protection. If the LEDs should become open in the circuit, the AL8841Q will stop oscillating; the SET pin will rise to VIN and the SW pin will then fall to GND. No excessive voltages will be seen by the AL8841Q.

Figure 10 illustrates the LED open protection procedure. In the waveform, channel 1 (yellow) is the GATE signal, channel 2 (red) is the CTRL signal, channel 3 (blue) is the LED-, and channel 4 (green) is the LED current. If the LED is open, the system operates in a low-current state. If the LED is connected, the system will resume normal operation.

Figure 10: LED Open Protection with 100% Duty

LED Short Protection

When the LED chain should become shorted together (the anode of the top LED becomes shorted to the cathode of the bottom LED) the AL8841Q will continue to switch and the current through the AL8841Q's internal switch will still be at the expected current. Thus, no excessive heat will be generated within the AL8841Q.

Figure 11 depicts the LED short protection procedure. In the waveforms, channel 1 (yellow) is the GATE signal, channel 2 (red) is the CTRL signal, channel 3 (blue) is the LED-, and channel 4 (green) the LED current. When the LED short circuits, the on-time of the internal power MOSFET switch is significantly reduced because almost all of the input voltage is now developed across the inductor. The off-time is significantly increased because the reverse voltage across the inductor is now the Schottky diode voltage, causing a much slower decay in inductor current.

LED Short Protection (continued)

Figure 11: LED Short Circuit Protection with 100% Duty

Thermal Test

Test condition: $V_{IN}=12V$, $V_O=6.6V$ (2LEDs), $T_a=26.6^{\circ}C$

Vin(V)	Iin(A)	Vout(V)	Iout(A)	Efficiency (%)	Power Inductor Temp($^{\circ}C$)	Diode Temp($^{\circ}C$)	IC Temp($^{\circ}C$)
12	0.6407	6.3323	1.00435	82.5	50.7	52.1	61.2

Conductive Emission Test

Test condition: VIN = 12V, VO = 6.6V (2LEDs)

1. CE+_0.15-28MHz CISPR 25 Class 5_Pass_5.24dB Margin

Frequency	MaxPeak	Average	Limit	Margin	Line	Corr.
MHz	dBμV	dBμV	dBμV	dB		dB
31.300000	---	14.08	24.00	9.92	Single Line	0.9
43.750000	16.36	---	34.00	17.64	Single Line	1.1
45.450000	16.10	---	34.00	17.90	Single Line	1.1
75.450000	---	7.89	18.00	10.11	Single Line	1.6
87.300000	17.21	---	34.00	16.79	Single Line	1.8
99.900000	---	11.08	18.00	6.92	Single Line	2.0
106.750000	---	12.76	18.00	5.24	Single Line	2.1

Conductive Emission Test (continued)

2. CE-_0.15-108MHz CISPR 25 Class 5_Pass_4.35dB Margin

Frequency	MaxPeak	Average	Limit	Margin	Line	Corr.
MHz	dB μ V	dB μ V	dB μ V	dB		dB
26.084000	---	9.40	24.00	14.60	Single Line	0.8
27.796000	15.43	---	44.00	28.57	Single Line	0.8
30.360000	---	13.07	24.00	10.93	Single Line	0.8
44.920000	15.37	---	34.00	18.63	Single Line	1.0
87.280000	17.53	---	34.00	16.47	Single Line	1.8
106.960000	---	13.65	18.00	4.35	Single Line	2.0

Conductive Emission Test (continued)

3. RE_0.15-28M CISPR 25 Class 5_Pass_9.73dB Margin

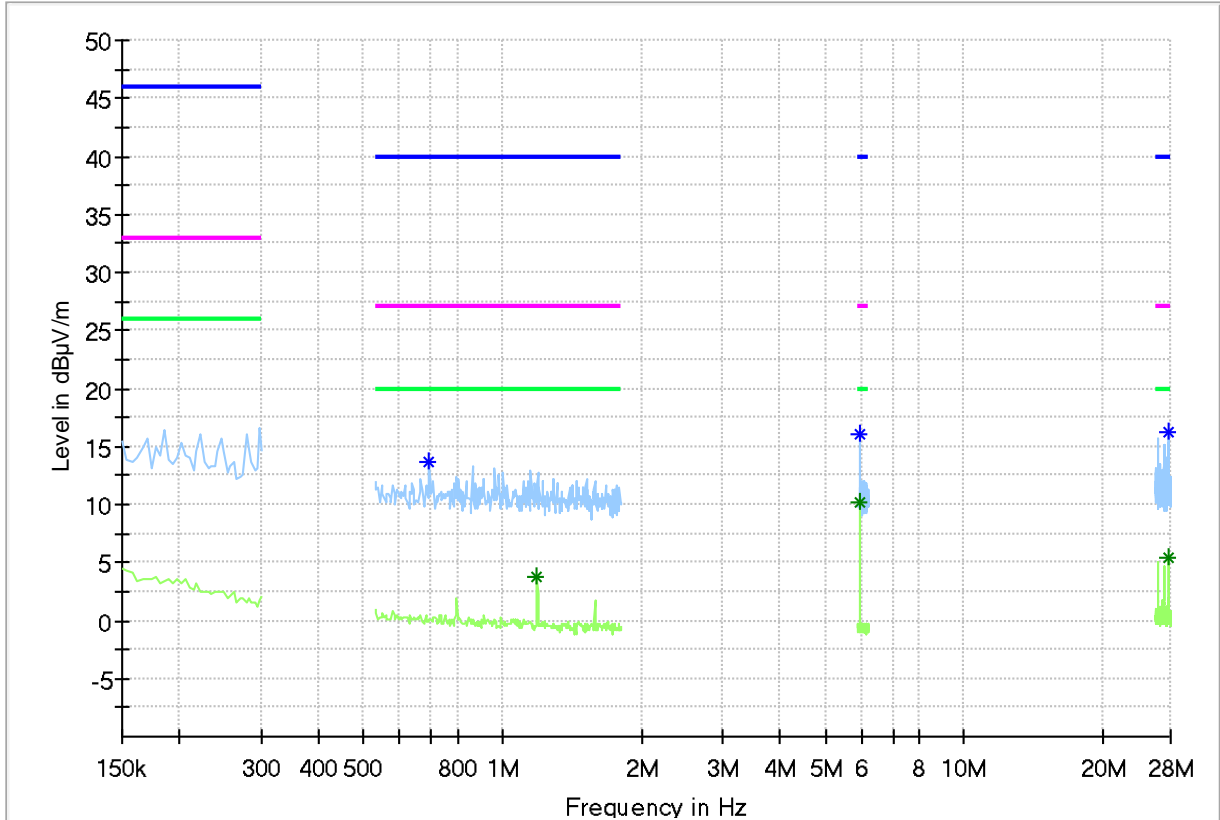

Frequency	MaxPeak	Average	Limit	Margin	Meas._Time	Bandwidth	Pol	Corr.
MHz	dBµV/m	dBµV/m	dBµV/m	dB	ms	kHz		dB/m
0.694000	13.76	---	40.00	26.24	---	---	V	10.0
1.190000	---	3.68	20.00	16.32	---	---	V	10.0
5.956000	16.12	---	40.00	23.88	---	---	V	10.2
5.956000	---	10.27	20.00	9.73	---	---	V	10.2
27.804000	---	5.49	20.00	14.51	---	---	V	10.3
27.804000	16.15	---	40.00	23.85	---	---	V	10.3

Conductive Emission Test (continued)

4. RE_30-200M_Horizontal_CISPR 25 Class 5_Pass_11.92dB Margin

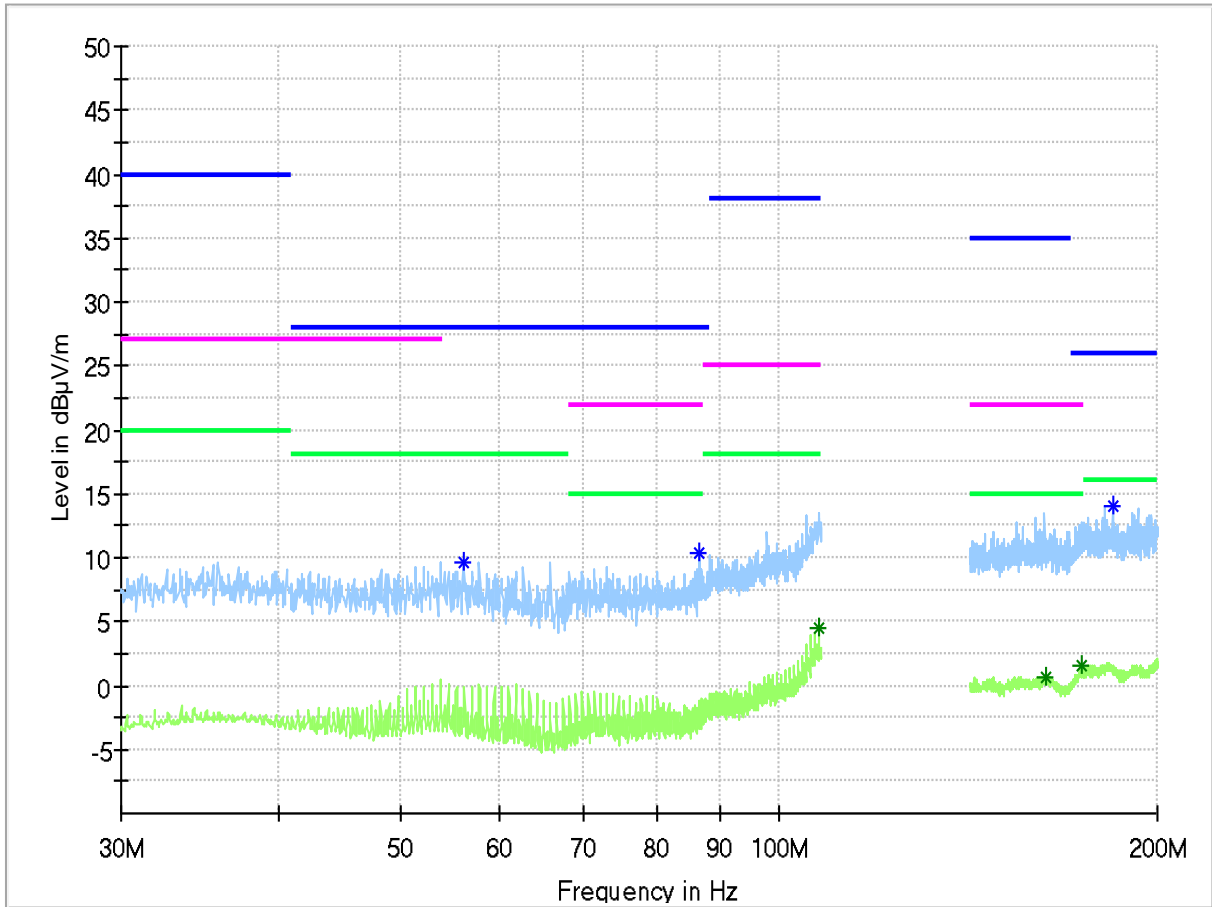

Frequency	MaxPeak	Average	Limit	Margin	Meas._Time	Bandwidth	Pol	Corr.
MHz	dBµV/m	dBµV/m	dBµV/m	dB	ms	kHz		dB/m
56.100000	9.63	---	28.00	18.37	---	---	H	-14.6
86.600000	10.44	---	28.00	17.56	---	---	H	-14.6
107.650000	---	4.55	18.00	13.45	---	---	H	-13.2
163.000000	---	0.71	15.00	14.29	---	---	H	-10.4
174.200000	---	1.47	15.00	13.53	---	---	H	-9.9
184.150000	14.08	---	26.00	11.92	---	---	H	-9.8

Conductive Emission Test (continued)

5. RE_30-200M_Verical_CISPR 25 Class 5_Pass_8.97dB Margin

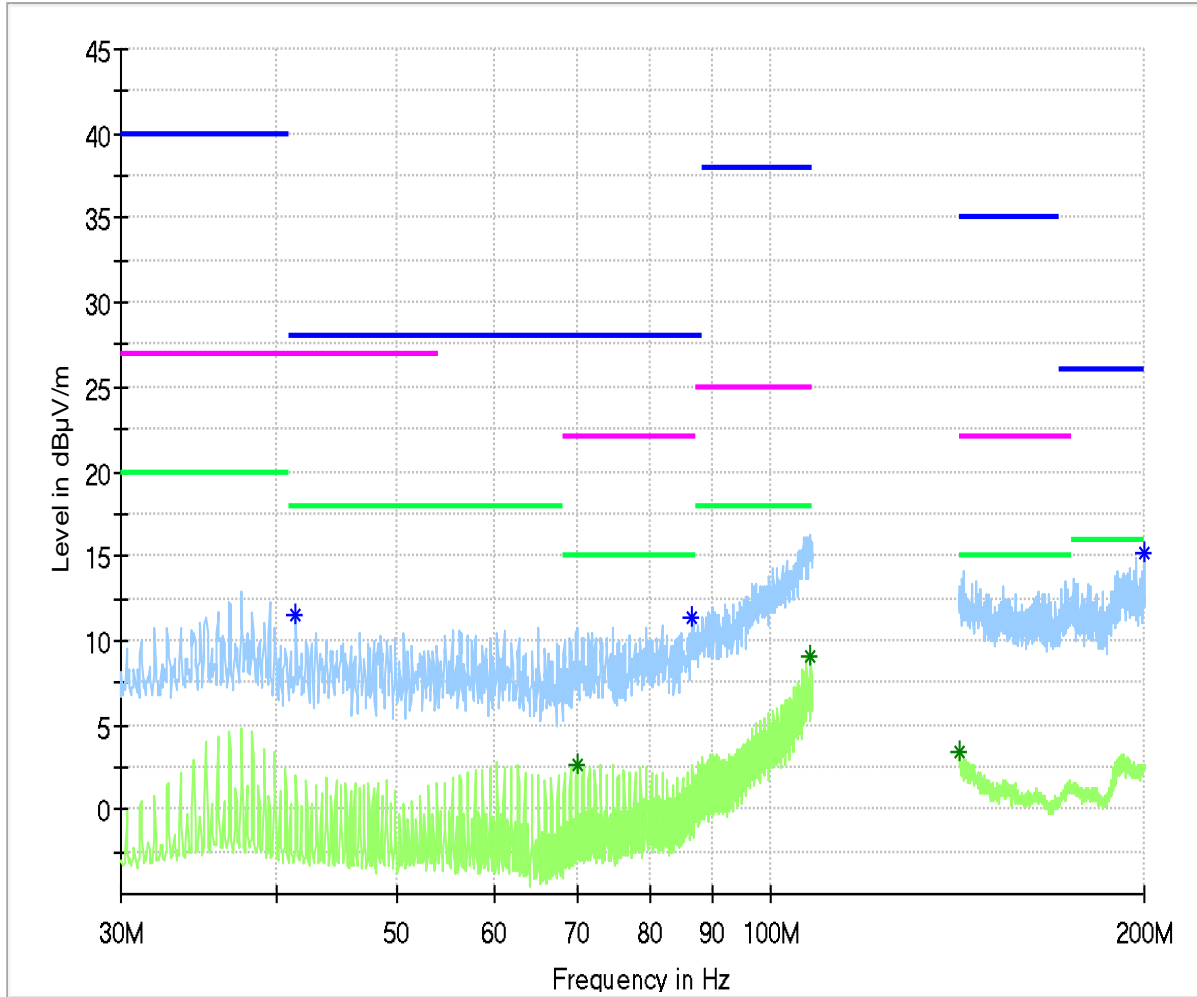

Frequency	MaxPeak	Average	Limit	Margin	Meas._Time	Bandwidth	Pol	Corr.
MHz	dBµV/m	dBµV/m	dBµV/m	dB	ms	kHz		dB/m
41.500000	11.58	---	28.00	16.42	---	---	V	-13.2
69.850000	---	2.68	15.00	12.32	---	---	V	-15.4
86.600000	11.41	---	28.00	16.59	---	---	V	-14.6
107.800000	---	9.03	18.00	8.97	---	---	V	-13.2
142.050000	---	3.40	15.00	11.60	---	---	V	-11.3
199.900000	15.13	---	26.00	10.87	---	---	V	-8.7

Conductive Emission Test (continued)

6. RE_200-960M_Horizontal_CISPR 25 Class 5_Pass_18dB Margin

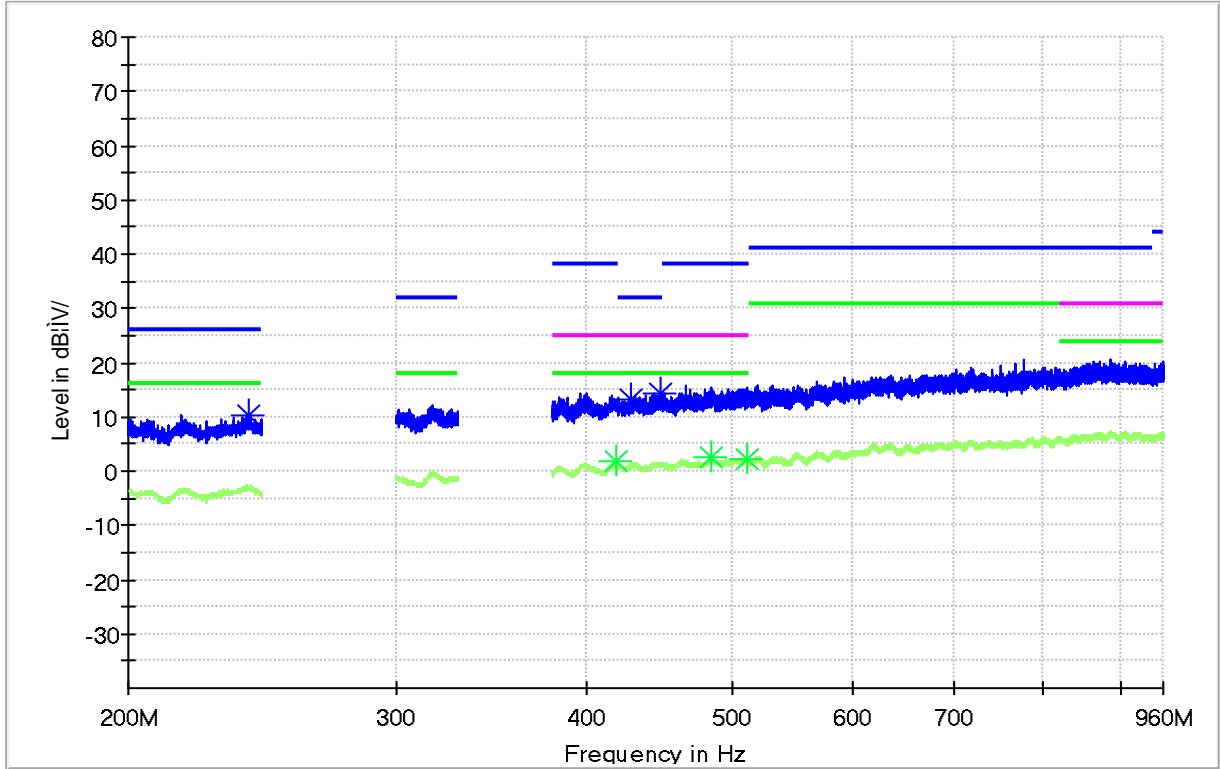

Frequency	MaxPeak	Average	Limit	Margin	Meas._Time	Bandwidth	Pol	Corr.	Comment
MHz	dBµV/m	dBµV/m	dBµV/m	dB	ms	kHz		dB/m	
240.100000	10.31	---	26.00	15.69	---	---	H	-12.5	11:22:34 - 2024/10/31
418.400000	---	1.68	18.00	16.32	---	---	H	-7.6	11:22:35 - 2024/10/31
427.950000	13.25	---	32.00	18.75	---	---	H	-8.0	11:22:34 - 2024/10/31
448.400000	14.41	---	32.00	17.59	---	---	H	-7.1	11:22:34 - 2024/10/31
483.400000	---	2.40	18.00	15.60	---	---	H	-6.6	11:22:35 - 2024/10/31
510.650000	---	2.32	18.00	15.68	---	---	H	-6.8	11:22:35 - 2024/10/31

Conductive Emission Test (continued)

7. RE_200-960M Vertical_CISPR 25 Class 5_Pass_14.72dB Margin

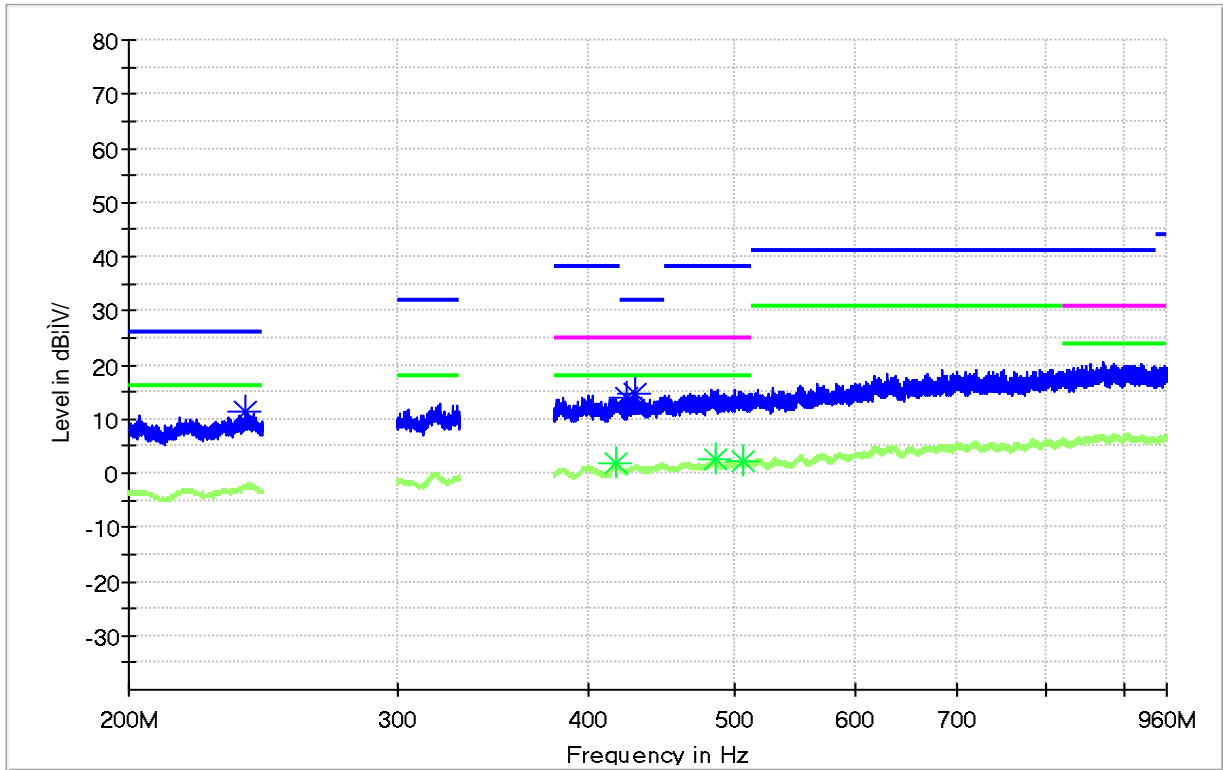

Frequency	MaxPeak	Average	Limit	Margin	Meas._Time	Bandwidth	Pol	Corr.	Comment
MHz	dBµV/m	dBµV/m	dBµV/m	dB	ms	kHz		dB/m	
238.400000	11.28	---	26.00	14.72	---	---	V	-12.4	11:30:12 - 2024/10/31
417.950000	---	1.75	18.00	16.25	---	---	V	-7.6	11:30:12 - 2024/10/31
424.300000	13.86	---	32.00	18.14	---	---	V	-8.1	11:30:12 - 2024/10/31
430.400000	14.75	---	32.00	17.25	---	---	V	-7.6	11:30:12 - 2024/10/31
484.800000	---	2.54	18.00	15.46	---	---	V	-6.6	11:30:12 - 2024/10/31
505.300000	---	2.38	18.00	15.62	---	---	V	-6.7	11:30:12 - 2024/10/31

Conductive Emission Test (continued)

8. RE_200-960M Horizontal_CISPR 25 Class 5_Pass_7.59dB Margin

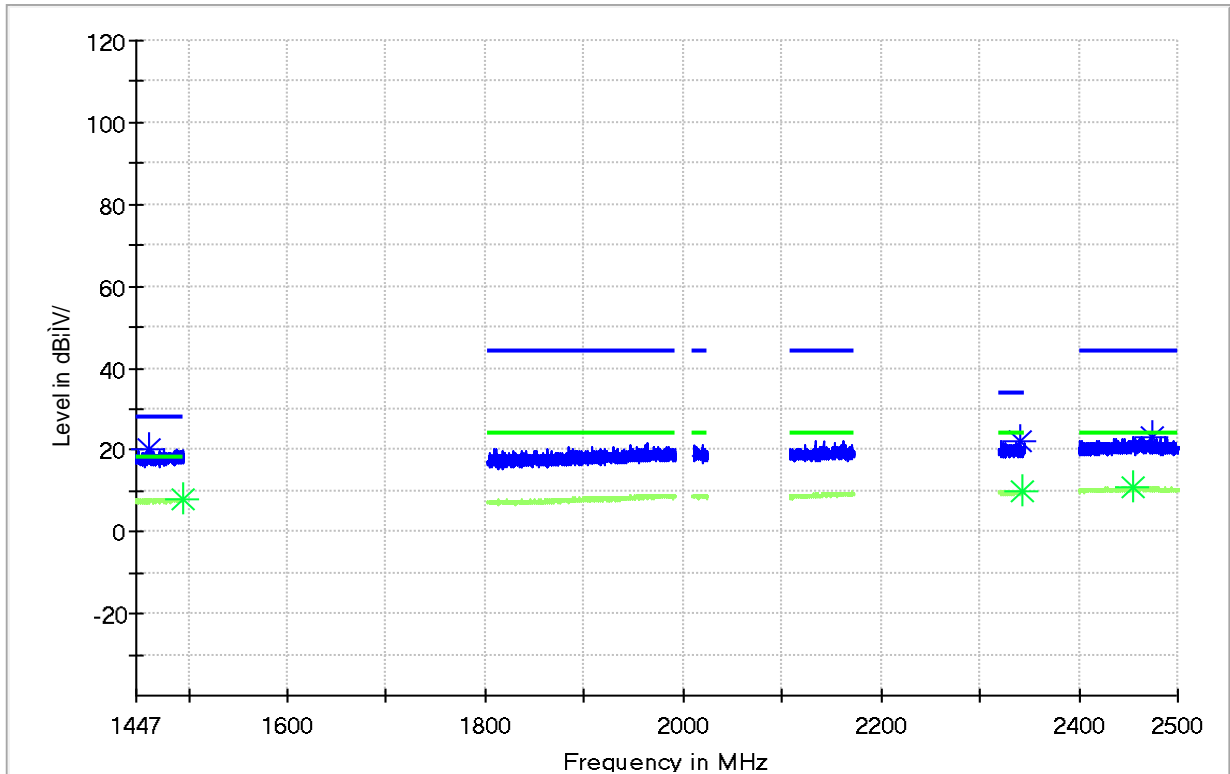

Frequency	MaxPeak	Average	Limit	Margin	Meas._Time	Bandwidth	Pol	Corr.	Comment
MHz	dBµV/m	dBµV/m	dBµV/m	dB	ms	kHz		dB/m	
1460.250000	20.41	---	28.00	7.59	5.0	120.000	H	-12.0	13:26:59 - 2024/10/31
1493.500000	---	8.07	18.00	9.93	5.0	120.000	H	-12.0	13:26:59 - 2024/10/31
2341.550000	22.30	---	34.00	11.70	5.0	120.000	H	-9.4	13:26:59 - 2024/10/31
2343.450000	---	10.11	24.00	13.89	5.0	120.000	H	-9.3	13:26:59 - 2024/10/31
2455.200000	---	10.96	24.00	13.04	5.0	120.000	H	-8.6	13:26:59 - 2024/10/31
2473.100000	23.05	---	44.00	20.95	5.0	120.000	H	-8.6	13:26:59 - 2024/10/31

Conductive Emission Test (continued)

9. RE_200-960M Vertical_CISPR 25 Class 5_Pass_7.83dB Margin

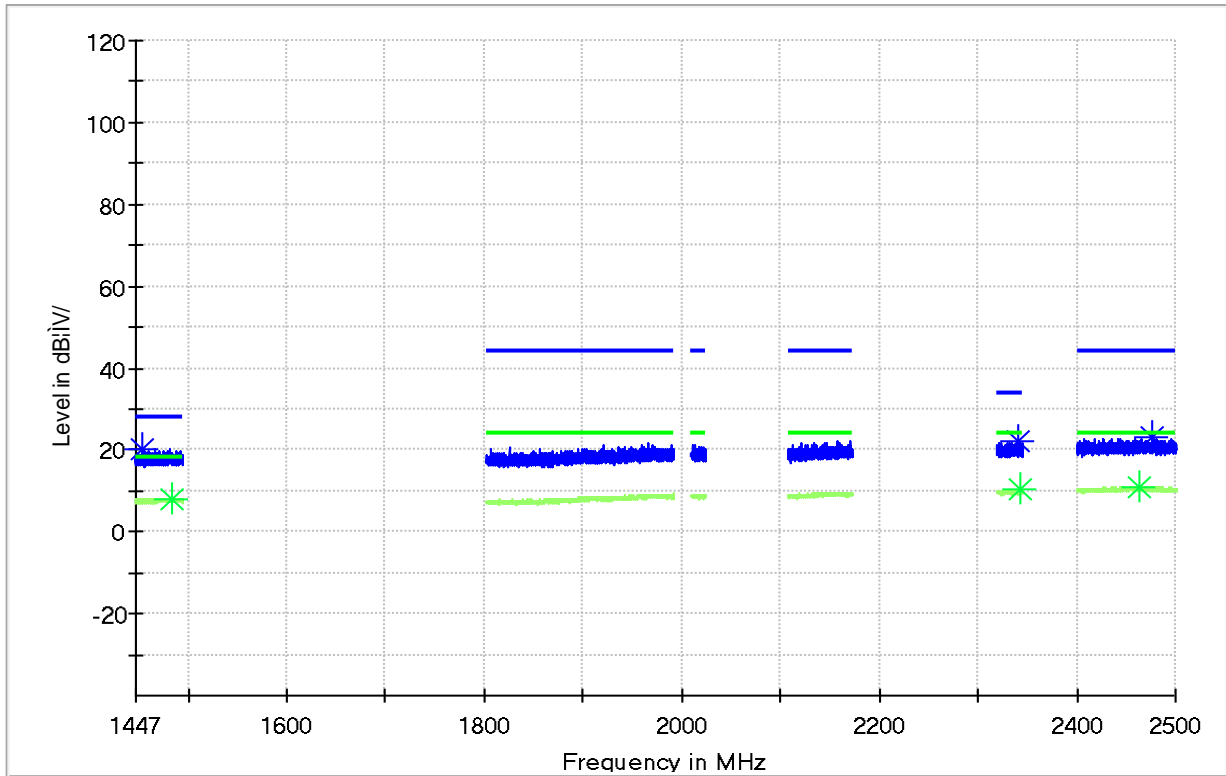

Frequency	MaxPeak	Average	Limit	Margin	Meas._Time	Bandwidth	Pol	Corr.	Comment
MHz	dBµV/m	dBµV/m	dBµV/m	dB	ms	kHz		dB/m	
1453.450000	20.17	---	28.00	7.83	5.0	120.000	V	-12.0	13:29:35 - 2024/10/31
1484.550000	---	8.19	18.00	9.81	5.0	120.000	V	-12.0	13:29:35 - 2024/10/31
2341.250000	21.97	---	34.00	12.03	5.0	120.000	V	-9.4	13:29:35 - 2024/10/31
2343.550000	---	10.27	24.00	13.73	5.0	120.000	V	-9.3	13:29:35 - 2024/10/31
2462.650000	---	11.04	24.00	12.96	5.0	120.000	V	-8.6	13:29:35 - 2024/10/31
2476.250000	23.19	---	44.00	20.81	5.0	120.000	V	-8.6	13:29:35 - 2024/10/31

IMPORTANT NOTICE

1. DIODES INCORPORATED (Diodes) AND ITS SUBSIDIARIES MAKE NO WARRANTY OF ANY KIND, EXPRESS OR IMPLIED, WITH REGARDS TO ANY INFORMATION CONTAINED IN THIS DOCUMENT, INCLUDING, BUT NOT LIMITED TO, THE IMPLIED WARRANTIES OF MERCHANTABILITY, FITNESS FOR A PARTICULAR PURPOSE OR NON-INFRINGEMENT OF THIRD PARTY INTELLECTUAL PROPERTY RIGHTS (AND THEIR EQUIVALENTS UNDER THE LAWS OF ANY JURISDICTION).
2. The Information contained herein is for informational purpose only and is provided only to illustrate the operation of Diodes' products described herein and application examples. Diodes does not assume any liability arising out of the application or use of this document or any product described herein. This document is intended for skilled and technically trained engineering customers and users who design with Diodes' products. Diodes' products may be used to facilitate safety-related applications; however, in all instances customers and users are responsible for (a) selecting the appropriate Diodes products for their applications, (b) evaluating the suitability of Diodes' products for their intended applications, (c) ensuring their applications, which incorporate Diodes' products, comply the applicable legal and regulatory requirements as well as safety and functional-safety related standards, and (d) ensuring they design with appropriate safeguards (including testing, validation, quality control techniques, redundancy, malfunction prevention, and appropriate treatment for aging degradation) to minimize the risks associated with their applications.
3. Diodes assumes no liability for any application-related information, support, assistance or feedback that may be provided by Diodes from time to time. Any customer or user of this document or products described herein will assume all risks and liabilities associated with such use, and will hold Diodes and all companies whose products are represented herein or on Diodes' websites, harmless against all damages and liabilities.
4. Products described herein may be covered by one or more United States, international or foreign patents and pending patent applications. Product names and markings noted herein may also be covered by one or more United States, international or foreign trademarks and trademark applications. Diodes does not convey any license under any of its intellectual property rights or the rights of any third parties (including third parties whose products and services may be described in this document or on Diodes' website) under this document.
5. Diodes' products are provided subject to Diodes' Standard Terms and Conditions of Sale (<https://www.diodes.com/about/company/terms-and-conditions/terms-and-conditions-of-sales/>) or other applicable terms. This document does not alter or expand the applicable warranties provided by Diodes. Diodes does not warrant or accept any liability whatsoever in respect of any products purchased through unauthorized sales channel.
6. Diodes' products and technology may not be used for or incorporated into any products or systems whose manufacture, use or sale is prohibited under any applicable laws and regulations. Should customers or users use Diodes' products in contravention of any applicable laws or regulations, or for any unintended or unauthorized application, customers and users will (a) be solely responsible for any damages, losses or penalties arising in connection therewith or as a result thereof, and (b) indemnify and hold Diodes and its representatives and agents harmless against any and all claims, damages, expenses, and attorney fees arising out of, directly or indirectly, any claim relating to any noncompliance with the applicable laws and regulations, as well as any unintended or unauthorized application.
7. While efforts have been made to ensure the information contained in this document is accurate, complete and current, it may contain technical inaccuracies, omissions and typographical errors. Diodes does not warrant that information contained in this document is error-free and Diodes is under no obligation to update or otherwise correct this information. Notwithstanding the foregoing, Diodes reserves the right to make modifications, enhancements, improvements, corrections or other changes without further notice to this document and any product described herein. This document is written in English but may be translated into multiple languages for reference. Only the English version of this document is the final and determinative format released by Diodes.
8. Any unauthorized copying, modification, distribution, transmission, display or other use of this document (or any portion hereof) is prohibited. Diodes assumes no responsibility for any losses incurred by the customers or users or any third parties arising from any such unauthorized use.
9. This Notice may be periodically updated with the most recent version available at <https://www.diodes.com/about/company/terms-and-conditions/important-notice>

The Diodes logo is a registered trademark of Diodes Incorporated in the United States and other countries.
All other trademarks are the property of their respective owners.
© 2024 Diodes Incorporated. All Rights Reserved.

www.diodes.com

Mouser Electronics

Authorized Distributor

Click to View Pricing, Inventory, Delivery & Lifecycle Information:

[Diodes Incorporated:](#)

[AL8841QEV1-EMC](#)