

Features

- ⊗ Compact biometric system
- ⊗ Onboard authentication software
- ⊗ Navigation support
- ⊗ Encrypted template storage
- ⊗ Multiple interfaces SPI/UART/USB/I2C
- ⊗ Single 3,3V power supply
- ⊗ Support for GPIO ports
- ⊗ Black matt protective sensor coating
- ⊗ All-in-one package and/or flex module
- ⊗ Feather wing and Arduino shield support
- ⊗ RoHS and REACH compliant

Applications

- ⊗ Access control, door locks
- ⊗ Crypto wallets
- ⊗ Fido authenticators, tokens
- ⊗ Digital access devices
- ⊗ Time and attendance

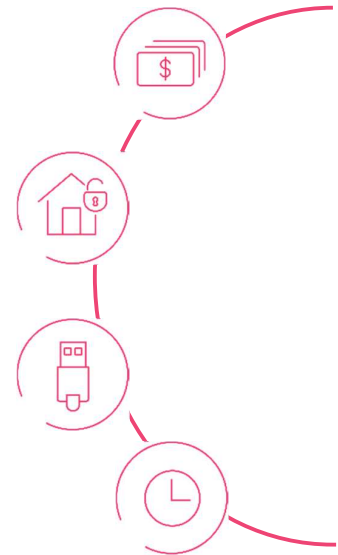

General description

Fingerprints Biometric System device family FPC2530 offers a proven, robust fingerprint sensor solution that can easily be integrated into virtually any application. Fingerprint templates are automatically created and stored in the internal flash memory. The device can be controlled from any host with basic commands for enrollment and verification, or be customized for stand-alone operation without external components. Fingerprints Biometric System device is provided with several different host interfaces, pre-loaded software and is ready to use on delivery. The Biometric System device comes with an appealing black coating, that together with a built-in hidden discharge node (bezel) provides protection against ESD, scratches, impact, and everyday wear and tear.

FPC2532AP
AllKey LGA

FPC2532AM
AllKey Module

FPC2534AP
AllKey Pro LGA

FPC2534AM
AllKey Pro Module



Table of Contents

- 1 INTRODUCTION 5
 - 1.1 Document content5
 - 1.2 FPC2530 device family5
 - 1.2.1 FPC2532 AllKey5
 - 1.2.2 FPC2534 AllKey Pro5
- 2 FUNCTIONAL DESCRIPTION 6
 - 2.1 Block diagram6
 - 2.2 Product features6
 - 2.3 Operating conditions6
 - 2.4 Electrical characteristics7
 - 2.5 Secure package layout7
 - 2.6 Signal configuration overview8
- 3 SOFTWARE 9
 - 3.1 Overview9
 - 3.2 States9
 - 3.3 Events9
 - 3.4 Communication Protocol10
 - 3.4.1 Frame Header10
 - 3.4.2 Command Header10
 - 3.5 Commands11
 - 3.6 Enrollment mode12
 - 3.7 Identify mode12
 - 3.8 Navigation mode13
 - 3.9 System configuration13
- 4 INTERFACES 14
 - 4.1 Interface overview14
 - 4.2 SPI communication14
 - 4.3 UART communication14
 - 4.4 USB and I2C communication14
- 5 MODES OF OPERATION 15
 - 5.1 Deep sleep mode15
 - 5.2 Finger detect mode15
 - 5.3 Active mode15
 - 5.4 Active mode, high performance15
 - 5.5 Reducing power consumption15
- 6 LGA INTEGRATION GUIDELINE 16
 - 6.1 Package outline16
 - 6.2 Pin numbering17
 - 6.3 Power supply and ground pins18



- 6.4 Interface selection pins.....18
- 6.5 Interface pins18
- 6.6 General purpose I/O pins (GPIO)18
- 6.7 ESD protection (EGND)19
- 6.8 Pins not used19
- 6.9 Underfill19
- 6.10 Adding a customized bezel19
- 6.11 Recommended solder pattern20
- 7 MODULE INTEGRATION GUIDELINE 21
 - 7.1 Module outline21
 - 7.2 Pin numbering21
 - 7.3 Power supply and ground21
 - 7.4 ESD protection (EGND)22
 - 7.5 Mating connector22
 - 7.6 Water and dust proof22
- 8 USER GUIDELINE 23
 - 8.1 Introduction23
 - 8.2 Finger placement23
 - 8.3 Enroll.....23
 - 8.4 Verify/Authenticate24
 - 8.5 Template update24
 - 8.6 Biometric performance.....24
 - 8.6.1 Abbreviations.....24
 - 8.7 Navigation.....25
- 9 DEVELOPMENT BOARDS 26
 - 9.1 FingerWing - Sensor feather wing26
 - 9.1.1 Overview26
 - 9.1.2 Product outline26
 - 9.1.3 Simplified schematic.....27
 - 9.1.4 Pin configuration28
 - 9.1.5 Interface selection29
 - 9.2 Shield - Arduino shield board.....30
 - 9.2.1 Overview30
 - 9.2.2 Shield default setup30
 - 9.2.3 DEEP SLEEP wakeup in UART mode.....30
 - 9.2.1 Product outline31
 - 9.2.2 Simplified schematic.....32
 - 9.2.3 Pin configuration33
 - 9.2.4 Interface selection33
 - 9.3 Flex (12p) breakout board34



9.3.1 Overview.....34

9.3.2 Product outline.....34

9.3.3 Simplified schematic.....34

9.3.4 Pin configuration.....35

9.3.5 Interface selection and ESD discharge path.....35

9.3.6 DEEP SLEEP wakeup in UART mode.....35

10 PRODUCT STRESS TESTING 36

10.1 Standard compliance - LGA package.....36

10.2 Standard compliance - Flex module.....36

10.3 Sensor surface properties.....37

11 ENVIRONMENTAL COMPLIANCE 38

11.1 Environmental regulations38

12 CUSTOMIZATION (ON REQUEST) 39

12.1 Customization project.....39

12.2 Device geometry.....39

12.3 General purpose IO.....39

13 ORDERING INFORMATION 40

13.1 Device name and Part numbers.....40

13.2 Production codes40

13.3 Shipping format40

13.4 ESD sensitive device.....40

14 REVISION HISTORY 41

14.1 Product specification (this document).....41

14.2 Product updates41

15 CONTACT INFORMATION..... 41



1 INTRODUCTION

1.1 Document content

This specification outlines the general features and functionalities of the FPC AllKey Biometric System. It includes mechanical and environmental information, integration guidelines as well as packing and ordering information for all versions. Regarding more advanced features like Secure Host Interface, and additional interface options like USB, I2C and GPIO use, we also refer to dedicated supplements, describing each feature set.

1.2 FPC2530 device family

The FPC AllKey Biometric System device family includes several biometric system devices, with different interface configurations and system functionalities. Most versions are available with a hardware compatible electrical and mechanical interface, allowing for future upgrades without the need for redesign.

Versions within the FPC2530 AllKey family at present date:

PRODUCT	DESCRIPTION	PRODUCT SPECIFICATION	FEATURE SUPPLEMENT
FPC2532AP	AllKey Biometric System LGA	FPC2530 (this document)	
FPC2532AM	AllKey Biometric System LGA	FPC2530 (this document)	
FPC2534AP	AllKey Pro Biometric System LGA	FPC2530 (this document)	FPC2534
FPC2534AM	AllKey Pro Biometric System Module	FPC2530 (this document)	FPC2534

1.2.1 FPC2532 AllKey

FPC2532 standard version is fully covered in this document and target applications where fingerprint is used to increase convenience by adding Identification, Personalization and Navigation. The FPC2532 is available both in an LGA package FPC2532AP, and a versatile flex module assembly FPC2532AM.

1.2.2 FPC2534 AllKey Pro

FPC2534 high security version target applications where fingerprint is used for Authentication and where Protection for Tampering is priority. The FPC2534 is available both in an LGA package FPC2534AP, and a versatile flex module assembly FPC2534AM.



2 FUNCTIONAL DESCRIPTION

2.1 Block diagram

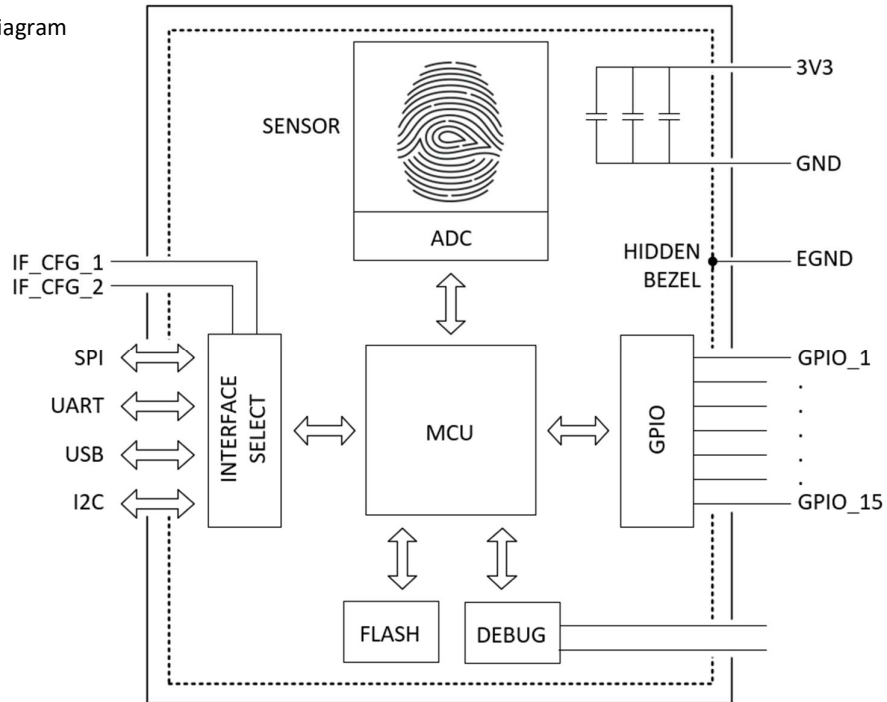

2.2 Product features

PARAMETER	DESCRIPTION	VALUE	UNIT
Dimension	Sensor body (Ø x T), nominal	11,0 x 0,83	mm
Active sensing area	Pixel matrix	5,0 x 4,8	mm
		100 x 96	pixel
Pixel resolution	256 gray scale values	8	bit
Spatial resolution		508	dpi
Package type	47 pin LGA, 8x8 matrix with 1,0 mm pitch	47	pin

2.3 Operating conditions

PARAMETER	CONDITION / DESCRIPTION	VALUE	UNIT
Operating temperature (max)	Ambient temperature, power applied	-40 ... 125	°C
Storage temperature (max)	Long term storage above RT will decrease shelf life (30 years shelf life is expected @25 °C)	-40 ... 85	°C
Floor life (out of bag)	JEDEC MSL Level 3 Compliant	168	hours
IP classification	Supported water and dust proof level	IP67	-



2.4 Electrical characteristics

SYMBOL	PARAMETER	CONDITION	MIN	TYP	MAX	UNIT
V_{DD}	Voltage supply (total)		3,0	3,3	3,6	V
I_{DD}	Current supply, active		-	17	21	mA
	Finger detect mode (FDM)	Waiting for finger		22		uA
	Active mode	Processing commands		5.2		mA
	Deep sleep mode			14		uA
<i>Digital inputs</i>						
V_{IL}	Logic '0' voltage		N/A	N/A	$0,3V_{DD}$	V
V_{IH}	Logic '1' voltage		$0,7V_{DD}$	N/A	N/A	V
<i>Digital outputs</i>						
V_{OL}	Logic '0' output voltage		-	-	0,4	V
V_{OH}	Logic '1' output voltage		2,4	-	-	V
	SPI Clock frequency			10	10	MHz
	UART baud rate	Default rate 921 600	9 600		921 600	baud

Note: All power consumption measurements are made with $V_{DD} = 3,3V$

2.5 Secure package layout

Extra precaution is taken to not expose critical signals on the outside of the SiP. Internal communication lines between the sensor, flash and MCU are all hidden inside the molded package body. To maintain integrity, signals cannot be accessed from the outside.



2.6 Signal configuration overview

Not all signals are available in all Biometric System devices. Refer to the section on “Customization” for more details on optional signals. Below is an overview of available signals (X) and interfaces in different product versions. Signals marked (-) are not available and should be left open (not connected).

PIN NAME	DESCRIPTION (default)	FPC2532AP	FPC2534AP	FPC2532AM	FPC2534AM
IF_CFG_1	Interface selection	X	X	X	X
IF_CFG_2	Interface selection	X	X	-	-
RST_N	System reset, active low	X	X	X	X
IRQ	Interrupt request	X	X	IRQ / HOST_WU *	IRQ / HOST_WU *
SPI_MOSI	SPI master out, slave in	X	X	X	X
SPI_MISO	SPI master in, slave out	X	X	X	X
SPI_SCK	SPI clock	X	X	X	X
SPI_CS_N	SPI chip select, active low	X	X	CS_N / SYS_WU *	CS_N / SYS_WU *
UART_TX	Serial interface, transmit	X	X	X	X
UART_RX	Serial interface, receive	X	X	X	X
USB_DP	USB data + (Optional)	-	X	-	-
USB_DM	USB data - (Optional)	-	X	-	-
I2C_SDA	I2C Data (Optional)	-	X	-	-
I2C_SCL	I2C Clock (Optional)	-	X	-	-
GPIO_1	General purpose IO	X	X	-	-
GPIO_2	General purpose IO	X	X	-	-
GPIO_3	General purpose IO	X	X	-	-
GPIO_4	General purpose IO	X	X	-	-
GPIO_5	General purpose IO	X	X	-	-
GPIO_6	General purpose IO	X	X	-	-
GPIO_7	General purpose IO	X	X	-	-
GPIO_8	General purpose IO	X	X	-	-
GPIO_9	General purpose IO	X	X	-	-
GPIO_10	General purpose IO	X	X	-	-
GPIO_11	General purpose IO	X	X	-	-
GPIO_12	General purpose IO	X	X	-	-
GPIO_13	General purpose IO	X	X	-	-
GPIO_14	General purpose IO	X	X	-	-
GPIO_15	General purpose IO	X	X	-	-
BOOT0	Do not connect	X	X	-	-
DBG_ (prefix)	Do not connect	-	-	-	-
3V3	Power supply	X	X	X	X
GND	Signal ground	X	X	X	X
EGND	Hidden bezel, ESD node	X	X	X	X
NO PAD	Pin ONE indication	-	-	-	-
NO PAD	Laser marking area	-	-	-	-

(*) NOTE: Dual functionality depending on SPI or UART interface selection, i.e. functionality in SPI mode (default) / UART mode. See more under FLEX MODULE section.



3 SOFTWARE

3.1 Overview

The software configuration on the device will depend on the feature set supported by the product variant. In this chapter is a summary of the common parts. For details on commands implementations, data types, and various defines, refer to the provided API header file (`fpc_api.h`) and sample code.

3.2 States

The internal state of the device is defined by a 2-byte bitmap. The table below gives an overview of the possible states. Note that some are mutually exclusive. For example, only one of Enroll, Identify, Navigation, and Capture can be active at a time. Attempting to enter multiple of these states simultaneously yields an error response.

STATE ID	NAME	CLEARED ON ABORT	DESCRIPTION
0x0001	App FW Ready	No	Application is ready to receive commands.
0x0004	Capture	Yes	Sensor is armed for a single touch. Transitions to <i>Image Available</i> state on capture. Note that the image cannot be used for biometric operations; this state is intended for debugging purposes and evaluating image quality.
0x0010	Image Available	Yes	A captured fingerprint image is available for readout. No biometrics can be performed on the image. State is cleared upon readout.
0x0040	Data Transfer	Yes	Data transfer session is ongoing.
0x0080	Finger Down	No	A finger is touching the sensor. Can only be entered if the sensor is actively searching for a finger (i.e. during Enroll, Identify, Navigation, or Capture).
0x0400	System Error	No	A system error has occurred. State will clear itself once the error code has been read out.
0x1000	Enroll	Yes	Enrollment of a new user is ongoing, and the sensor is armed for multiple touches. State will clear itself once enrollment finishes.
0x2000	Identify	Yes	Identification/Verification of user is ongoing, and the sensor is armed for a single touch. State will clear itself once the match result is reported.
0x4000	Navigation	Yes	Sensor is primed for detection and classification of navigation gestures.

3.3 Events

A change in the internal state is communicated as an *event*. They can occur as a response to a request (e.g. an enrollment request), a touch of the sensor, or the outcome of some internal operation (e.g. fingerprint matching). All events are reported to the host as part of a status response, which also contains the current state. A status response will always be sent in response to any command, and in case there is no special event which occurred, it is seen as an “empty” event. Below is a list of possible events, which are also defined in the API header file.

EVENT ID	NAME	DESCRIPTION
0	None / Empty event	No special event occurred.
1	Idle	Triggers on device startup.
2	Armed	Not in use.
3	Finger Detect	Triggers on touch if the sensor is searching for a finger. The device enters “Finger Down” state on this event.
4	Finger Lost	Triggers if a finger leaves the sensor area. The device exits “Finger Down” state on this event.
5	Image Ready	Sensor has captured an image.
6	Command Failed	The requested command failed. Typically accompanied by an error code.



3.4 Communication Protocol

All data transfers have a *Frame Header*, *Command Header* and, where applicable, *Command Payload Data*. This applies to all messages in both directions.

FRAME HEADER	COMMAND HEADER	COMMAND DATA (PAYLOAD)
8 bytes	4 bytes	Variable

All structs and defines described in this document can be found in the API header files and sample code. The data fields in the API header files use size-specific datatypes defined in `stdint.h` (e.g., `uint16_t`, etc.).

All fields are in little endian format.

3.4.1 Frame Header

All Requests, Responses and Events start with a Frame Header.

The header contains information on what version of the protocol and what type of message it is, and the length of the following payload. The size of the frame header is 8 bytes.

If the VERSION field does not match between device and host, the frame will be discarded.

VERSION	TYPE	FLAGS	PAYLOAD SIZE
2 bytes	2 bytes	2 bytes	2 bytes

3.4.2 Command Header

All commands have a common command header. The payload depends on the command. The size of the command header is 4 bytes.

COMMAND ID	TYPE	COMMAND DATA (PAYLOAD)
2 bytes	2 bytes	Variable



3.5 Commands

This table below contains all common commands supported by the FPC2530 device family.

“Command” and “Request” are used interchangeably, and both refer to a data transfer initiated by the host.

ID	NAME	DESCRIPTION
0x0040	Status	Get the status of device.
0x0041	Version	Get FW version.
0x0044	Built-in Self-Test (BIST)	Run internal test for defects on the fingerprint sensor.
0x0050	Capture	Arm the sensor to capture a single image on touch.
0x0052	Abort	Abort active state(s). See Section 3.2 for which states can be aborted.
0x0053	Image Data	Request readout of fingerprint image collected in <i>Capture</i> mode.
0x0054	Enroll	Put the device in Enrollment state. The device will register each touch of the sensor until enrollment finishes.
0x0055	Identify	Put device in Identify state (one touch) to perform matching against saved templates on touch.
0x0060	List Templates	List enrolled templates.
0x0061	Delete Template(s)	Delete one or all enrolled templates.
0x006A	Get System Configuration	Get active or default system configuration settings.
0x006B	Set System Configuration	Set system configuration settings.
0x0072	Reset	Reset device.
0x00B0	Set Debug Log Level	Not supported. Only Critical logs can be read out.
0x0101	Data Get	Read out one chunk of requested data from buffer. A data request, such as <i>Image Data</i> , must be sent prior.
0x0200	Navigation	Put the device in Navigation mode.
0x0300	GPIO Control	Set or get configuration for GPIO pins. Refer to Section 6.6 for details.



3.6 Enrollment mode

Enrollment mode consists of the full enrollment of a new fingerprint, from capturing images, providing continuous feedback, and saving the template to the internal flash. An overview of the enrollment flow is displayed to the right.

It is initiated by the Enroll command, with the optional argument of an ID to register the template under. If no ID is specified, it will use the next number available. The enroll request is validated by a status event, signaling that enrollment successfully started.

Once enrollment is started, the device continuously checks for a finger on its sensor to enroll. Each touch is registered, and feedback is provided on the image quality and remaining touches. The loop continues until sufficient information has been registered of the fingerprint and will return to its idle state afterwards.

The enrollment can be cancelled either by the host or the device. From the host side, it is cancelled by sending the abort command at any point which returns the device to its idle state. Similarly, the device may abort enrollment if multiple images in a row are of insufficient quality. It will then exit with the appropriate error code. Note that if either side aborts, all registered data so far is discarded – nothing is saved until the full enrollment finishes successfully.

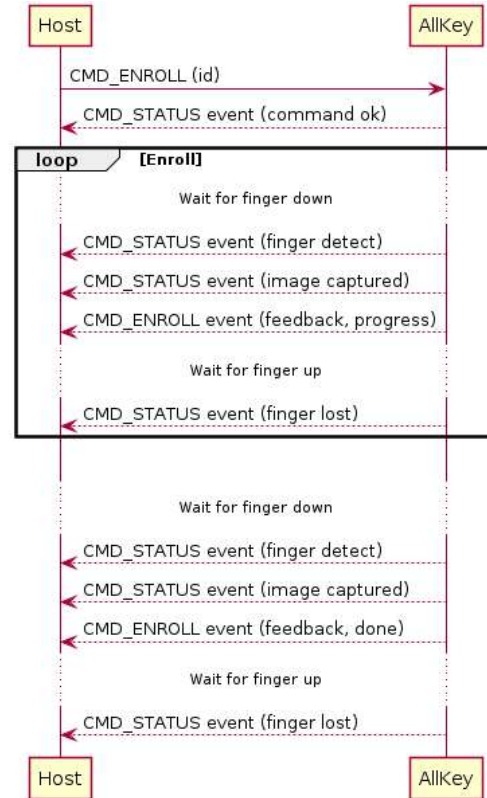

3.7 Identify mode

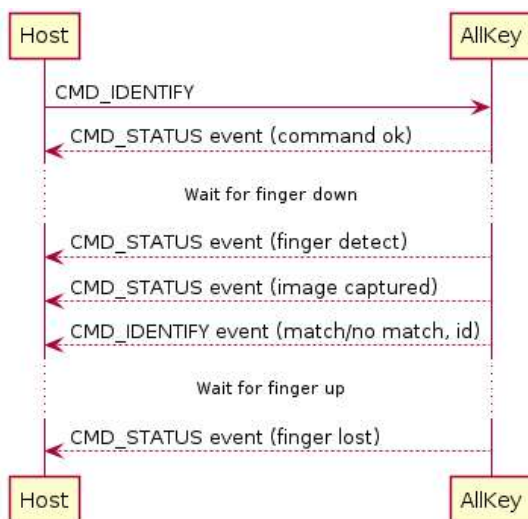

When identify mode is entered, the sensor is armed to capture a single image on touch. The device will try to match the image against *any* template on the device, or a specific one (i.e. verify), if specified in the Identify command payload. The outcome and the match ID are returned as an event, and the device returns to its idle state once the finger is lifted.

Note that identify mode consists of a *single* attempt. The mode must be re-entered again after the match response is given and the finger is lifted.

If too many unsuccessful attempts are made, the device will be locked out from identify for some time, preventing further attempts. The number of fails, and the lockout time can be changed via the system configuration (see Section 3.9).



3.8 Navigation mode

The device also provides the possibility of performing simple navigational gestures, such as traversing a menu. This is handled in *navigation mode*, which continuously checks for a finger on the sensor. Instead of capturing and processing an image, the device tracks and categorizes any gestures performed. It may either be classified as a swipe in one of the four cardinal directions (up, down, left, right), a press, or a long press. Navigation events are sent to the host on any gesture, as seen in the diagram below. To exit navigation, an abort request must be sent from the host.

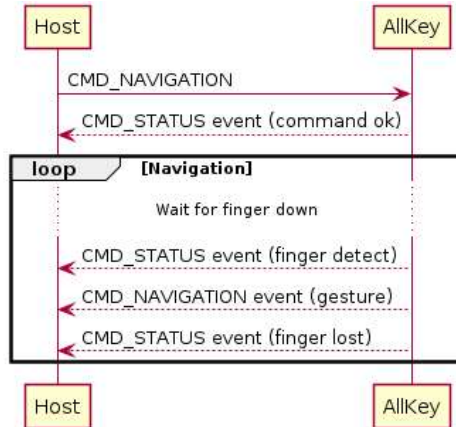

3.9 System configuration

A few parameters for the software can be configured by the host. The table below lists all available settings and their default values. These are FPC recommended settings, and do not need to be changed. The exception is “Stop mode for UART” flag which should be enabled in the final integration if power consumption is a restriction. See sections 4.3 and 5 for details.

CONFIG	DEFAULT	DESCRIPTION	
Version	1	Version of system configuration structure. Shall always be set to 1.	
Finger Scan interval	34 ms	Sleep time between each finger presence check. A higher value will decrease power consumption in Finger Detect Mode, but also increase response time.	
System Flags	Status event at boot	Enabled	Send Status event after system boot.
	Stop mode for UART	Disabled	Let system go into deep sleep when using UART interface. This requires the system to be woken via the wake-up pin (CS) before sending any UART data to host.
	UART IRQ before TX	Enabled	Set IRQ pin before SiP sends UART data. The delay between the IRQ and start of data transfer is configurable via “UART delay before TX” below.
UART delay before TX	1 ms	Delay between the IRQ pin is set, and UART TX is started.	
Idle time before sleep	0 ms	Idle time after last command before entering deep sleep.	
Identify lockout	Max consecutive fails	5	Number of consecutive fails to trigger a lockout. The lockout is activated on the next failure i.e. 6 th no-match for default setting.
	Lockout time	15 s	Lockout time. The lockout is cleared upon FW reset.



4 INTERFACES

4.1 Interface overview

The FPC2530 module supports a variety of HW interfaces. SPI and UART are supported in all SW variants. Other interfaces may be supported depending on SW. The interface selection will adhere to the table in the section "Interface selection pins (IF CONFIG)".

4.2 SPI communication

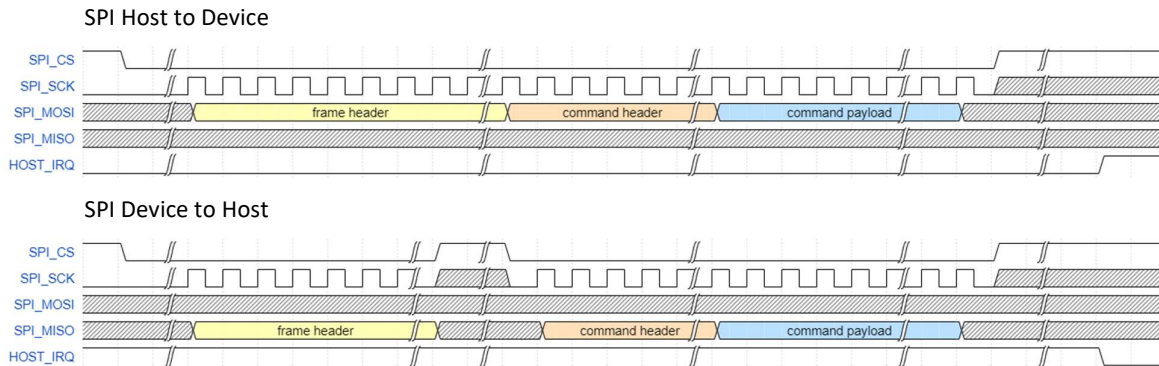

Time between chip select low and first clock flank must be > 500 us to let the MCU wake from sleep state. Frames from Host must be sent without toggling the chip select during the transfer. For frames read by the host, the frame header is usually read first and then the rest of the frame. Chip select can be toggled multiple times while reading.

4.3 UART communication

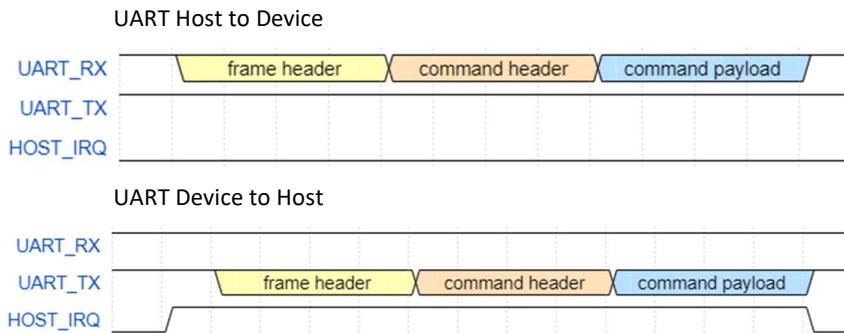

Transfer from device to host will be sent 1ms after HOST_IRQ goes high (this value is configurable, see Section 3.9). The HOST_IRQ is used to let the host device wake from sleep if needed.

To wake the device from sleep, the HOST_CS_N line must be toggled. If fewer pins are needed, the HOST_CS_N line can be connected to HOST_UART_RX instead and a break character can be sent before sending the normal frame. The break length must be > 1 character in length (baud rate dependent, ~10us at 921600 baud).

4.4 USB and I2C communication

Only supported for FPC2534. See feature supplement for additional details.



5 MODES OF OPERATION

This product has 4 different power modes. In most cases, the software automatically defaults to the lowest applicable mode to minimize power consumption. The subsections below describe each mode, when its used, and ways of minimizing consumption.

5.1 Deep sleep mode

Deep sleep mode refers to the lowest power state when the fingerprint sensor is also in deep sleep. This mode may also be referred to as Stop mode interchangeably. For SPI interface, this is automatically entered when the device is idle.

5.2 Finger detect mode

Finger detect mode refers to when the device is waiting for a finger to touch the sensor or waiting for a finger to leave the sensor area (enroll/identify/navigation states). No other data is being processed by the device during finger detect mode. It is activated during Enroll, Identify, Navigation, and Finger Down states.

5.3 Active mode

Active mode refers to when the device is fully awake and processing data or communicating with internal hardware. Any requests and communication with the device will put it in active mode, as well as processing navigation gestures. Based on the system configuration it will re-enter deep sleep or finger detect after a while.

5.4 Active mode, high performance

High performance mode is only activated in short periods when greater processing power is required. It is automatically entered or exited by the device; it cannot be controlled by the host. The high-performance mode is only used for processing a captured fingerprint image for enrollment or identification purposes, as well as listing all templates.

5.5 Reducing power consumption.

Below are a few suggestions on how to reduce power consumption in the software implementation. Note that these are dependent on the end use case and may not be applicable in all situations.

- ④ If using UART mode, make sure to enable “Stop mode for UART” flag in the system configuration for the final product. Note that it requires the device to be woken via CS pin before sending any data.
- ④ If the end solution allows it, avoid idling in Finger detect mode. Scanning for a finger on the sensor slightly increases power consumption (see Section 2.4). Instead, only enter these modes when needed.
 - If this is not possible, e.g. if the system is intended to wake up on a finger detect, consider increasing the finger scan interval in the system configuration.
- ④ If the purpose is only to verify the identity of a known user, consider specifying their ID in the Identify command. Matching is done in high performance mode, and it is faster to match against a single template, rather than the entire database.



6 LGA INTEGRATION GUIDELINE

6.1 Package outline

The standard package within the FPC2530 device family is a round LGA (land grid array) with a small notch as pin one indication. Top side is coated black and bottom side gives access to all signals.

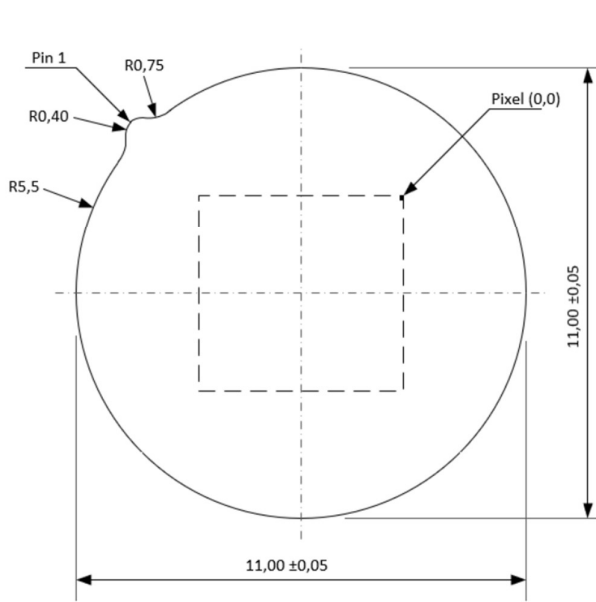

TOP VIEW

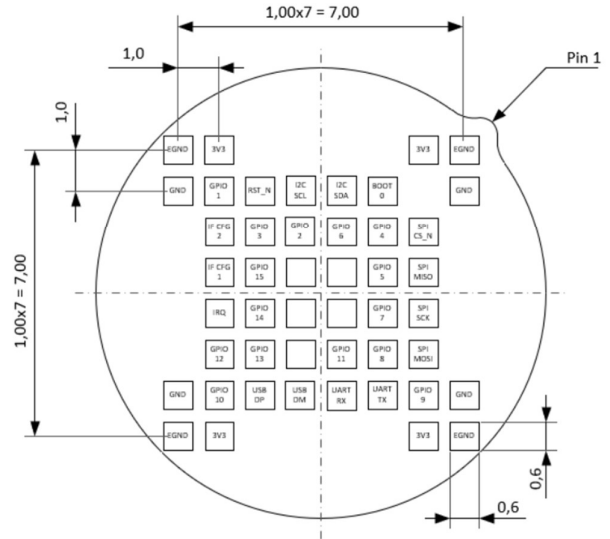

BOTTOM VIEW



SIDE VIEW

[mm]



6.2 Pin numbering

Default configuration

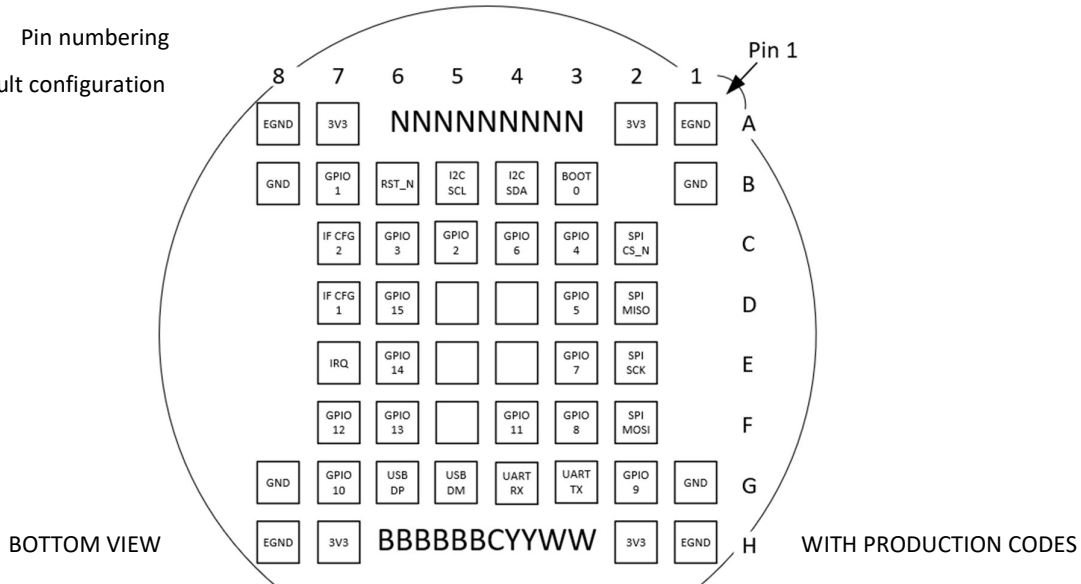

PIN	NAME	DESCRIPTION	PIN	NAME	DESCRIPTION
A1	EGND	Hidden bezel, ESD node	E1	NO PAD	Laser marking area
A2	3V3	Power supply	E2	SPI_SCK	SPI clock
A3	NO PAD	Laser marking area	E3	GPIO_7	General purpose IO
A4	NO PAD	Laser marking area	E4	DBG_UART_RX	Do not connect
A5	NO PAD	Laser marking area	E5	DBG_SWCLK	Do not connect
A6	NO PAD	Laser marking area	E6	GPIO_14	General purpose IO
A7	3V3	Power supply	E7	IRQ	Interrupt request
A8	EGND	Hidden bezel, ESD node	E8	NO PAD	Laser marking area
B1	GND	Common ground	F1	NO PAD	Laser marking area
B2	NO PAD	Pin ONE indication	F2	SPI_MOSI	SPI master out, slave in
B3	BOOT0	Do not connect	F3	GPIO_8	General purpose IO
B4	I2C_SDA	I2C Data	F4	GPIO_11	General purpose IO
B5	I2C_SCL	I2C Clock	F5	DBG_UART_TX	Do not connect
B6	RST_N	System reset, active low	F6	GPIO_13	General purpose IO
B7	GPIO_1	General purpose IO	F7	GPIO_12	General purpose IO
B8	GND	Common ground	F8	NO PAD	Laser marking area
C1	NO PAD	Laser marking area	G1	GND	Common ground
C2	SPI_CS_N	SPI chip select, active low	G2	GPIO_9	General purpose IO
C3	GPIO_4	General purpose IO	G3	UART_TX	Serial interface, transmit
C4	GPIO_6	General purpose IO	G4	UART_RX	Serial interface, receive
C5	GPIO_2	General purpose IO	G5	USB_DM	USB data -
C6	GPIO_3	General purpose IO	G6	USB_DP	USB data +
C7	IF_CFG_2	Interface selection, config pin 2	G7	GPIO_10	General purpose IO
C8	NO PAD	Laser marking area	G8	GND	Common ground
D1	NO PAD	Laser marking area	H1	EGND	Hidden bezel, ESD node
D2	SPI_MISO	SPI master in, slave out	H2	3V3	Power supply
D3	GPIO_5	General purpose IO	H3	NO PAD	Laser marking area
D4	DBG_SWO	Do not connect	H4	NO PAD	Laser marking area
D5	DBG_SWCLK	Do not connect	H5	NO PAD	Laser marking area
D6	GPIO_15	General purpose IO	H6	NO PAD	Laser marking area
D7	IF_CFG_1	Interface selection, config pin 1	H7	3V3	Power supply
D8	NO PAD	Laser marking area	H8	EGND	Hidden bezel, ESD node



6.3 Power supply and ground pins

The LGA package is provided with four pins for power supply, and four ground pins. Even if it may be enough to connect only two of these pins, it is recommended to connect all eight pins for optimal power supply stability. Package is equipped with internal decoupling and hence the need for external decoupling is limited in most applications. If space is limited, connections are short (< 30 mm), and power supply can be considered stable, omitting external decoupling capacitors can be evaluated.

6.4 Interface selection pins

Different product versions of the FPC2530, offers a choice of up to four interfaces. In order to select the desired interface, two configuration pins are used. These pins can be hard wired high (3V3) or low (GND) in the final application, when the final interface is selected, assuming only one interface is used.

INTERFACE	IF_CFG_1	IF_CFG_2	COMMENT
SPI	LOW	LOW	Standard interface available on FPC2532
UART	HIGH	LOW	Standard interface available on FPC2532
USB	LOW	HIGH	Optional interface
I2C	HIGH	HIGH	Optional interface

6.5 Interface pins

The functionality of all interface pins are described in previous section “Interfaces”.

Since multiple interfaces are supported, some pins have dual use depending on IF CONFIG selection. This implementation is also described more in the “Module integration guideline” section.

PIN NAME	DESCRIPTION (SPI/default)	DESCRIPTION (UART mode)	SPI mode	UART mode
IF_CFG_1	Interface selection, config pin 1	Interface selection, config pin 1	LOW	HIGH
IF_CFG_2	Interface selection, config pin 2	Interface selection, config pin 2	LOW	LOW
IRQ	Interrupt request / Host wakeup	Host wakeup	IRQ	HOST_WU
SPI_MOSI	SPI master out, slave in	General purpose IO	MOSI	GPIO_31
SPI_MISO	SPI master in, slave out	General purpose IO	MISO	GPIO_32
SPI_SCK	SPI clock	General purpose IO	SCK	GPIO_33
SPI_CS_N	SPI chip select, active low	System wakeup	CS_N	SYS_WU
UART_TX	General purpose IO	Serial interface, transmit	GPIO_21	TX
UART_RX	General purpose IO	Serial interface, receive	GPIO_22	RX

6.6 General purpose I/O pins (GPIO)

Different versions of the FPC2530 incorporates different functionalities on the available GPIO pins (see below). In fact each of the GPIO pins can be configured as output (push-pull or open-drain), as input (with or without pull-up or pull-down) or as peripheral alternate function. Most of the GPIO pins are shared with digital or analog alternate functions. Refer to the applicable feature supplement or section about “Customization” for more details on specific GPIO signals and how they can be customized for different applications.

GPIO pin	FPC2532	FPC2534	COMMENT
1 to 15	Configured in SW	Configured in SW	Not available on module level
21, 22,31,32,33	Configured in SW	Configured in SW	Depend on interface selection



6.7 ESD protection (EGND)

All LGAs are equipped with a built in ESD drain node, a so-called hidden bezel. Purpose with this feature is to redirect a potential high voltage discharge to the local ESD drain node (EGND). This drain feature works in combination with the durable sensor surface coating, that will safely deflect potential ESD discharges to the hidden bezel structure, and hence providing a robust protection against a surface breakdown.

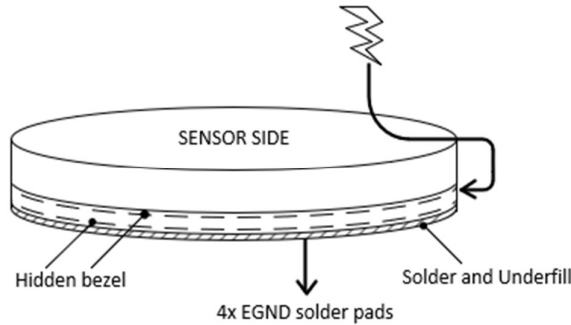

It is recommended to connect all four EGND pins directly to protective ground for best performance.

6.8 Pins not used

The LGA implements an 8x8 pin matrix pattern, but some locations are not used. Especially B2 is left blank to provide a “pin one” indication for easy orientation of the package back side. This blank pin also coincides with the package notch. Four positions on each side, are left blank to offer space for device marking.

Five pins in the center region with DBG prefix are shown as “do not connect. They are only intended for manufacturing.

6.9 Underfill

It is recommended to seal the solder joints by means of underfill to improve environmental durability and/or to meet a specific IP classification (water proofing). However, pay attention to not cover the hidden bezel structure embedded in the LGA package. Covering the hidden bezel structure will reduce the tolerance to external ESD discharges.

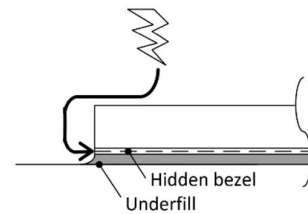

6.10 Adding a customized bezel

A customized bezel can be added to enhance the visual appearance in the end user application. Regardless, proper access to an ESD discharge node (hidden bezel or EGND) is required to maintain the ESD resistance.

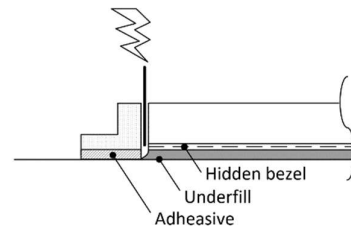

When applying underfill as described above, extra precaution needs to be taken not to cover the hidden bezel pattern on the package sides. Metal bezels are preferably grounded (EGND), and hence access to the hidden bezel is of less importance. When adding a non-conductive bezel or casing in combination with underfill, the same requirement for hidden bezel access applies.

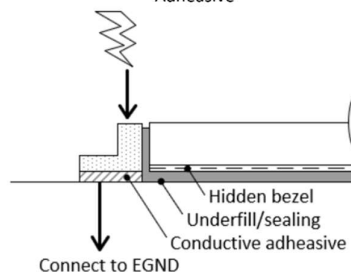



6.11 Recommended solder pattern

The FPC2530 family LGAs are provided with squared 0,6 mm solder-mask-defined (SMD) pads. It is recommended to use a mirrored pad pattern on the receiver PCB as shown below. On Fingerprints Development boards, 0,6 mm NSMD pads with a 0,7 mm solder mask opening are used (see below), but other designs may be possible. Stencil openings are the same as the exposed Cu.

TOP VIEW (receiver PCB)

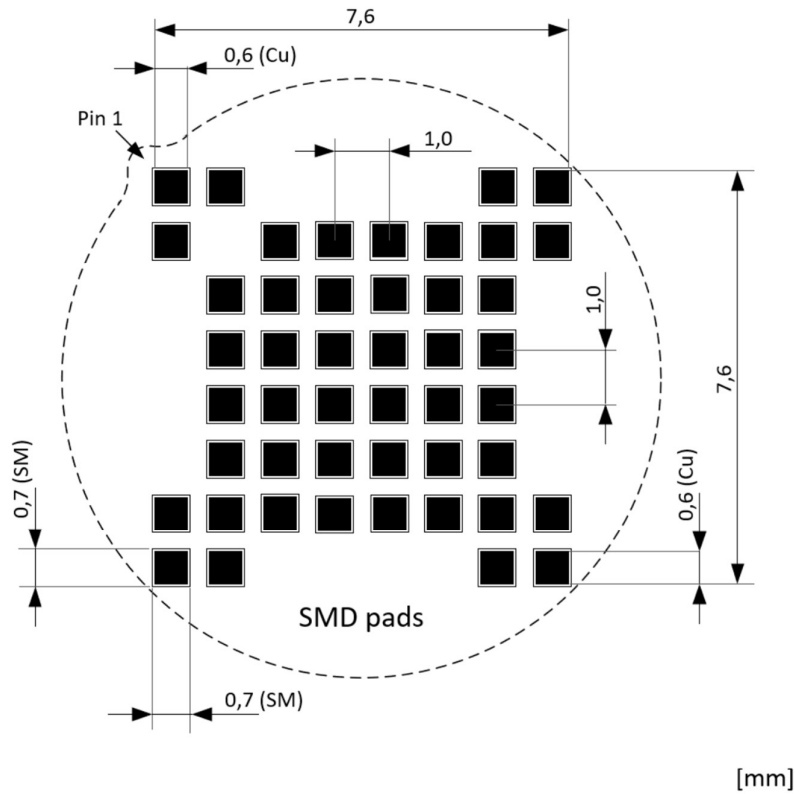



7 MODULE INTEGRATION GUIDELINE

7.1 Module outline

The Biometric Systems module has an integrated bezel in stainless steel. The bezel is grounded and operates together with the integrated ESD protection system for optimal performance. On the flex side there is a 12 pin ZIF (zero insertion force) connector pattern. Sensor facing up, connectors facing down. This allows for a low-cost connection to the host system. One recommended connector, used on Fingerprints development boards, is provided below in the “Mating connector section”.

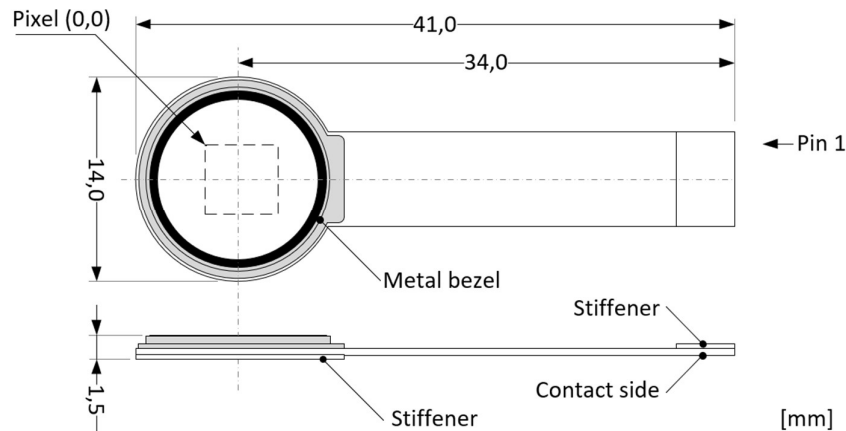

7.2 Pin numbering

PIN	NAME	DESCRIPTION	CONFIG = low	CONFIG = high
1	CONFIG *	Interface select	SPI interface active	UART interface active
2	TX	UART TX	GPIO_21	TX
3	RX	UART RX	GPIO_22	RX
4	IRQ	Interrupt request	IRQ	HOST_WU (host wakeup)
5	MOSI	SPI master out slave in	MOSI	GPIO_31
6	MISO	SPI master in slave out	MISO	GPIO_32
7	SCK	SPI serial clock	SCK	GPIO_33
8	CS_N	SPI chip select, active low	CS_N	SYS_WU (system wakeup)
9	RST_N	System reset, active low	RST_N	RST_N
10	3V3	Power supply	3V3	3V3
11	GND	Internal use	GND	GND
12	EGND	ESD ground node, bezel	EGND	EGND

(*) NOTE: CONFIG is identical with IF_CFG_1, and IF_CFG_2 is internally hard wired to limit interfaces to SPI and UART

7.3 Power supply and ground

The flex module use one single power line and one ground connection. The module is further equipped with internal decoupling and hence the need for external decoupling is limited in most applications. If space is limited, additional connections are short (< 30 mm), and power supply can be considered stable, omitting dedicated external decoupling capacitors may be evaluated.



7.4 ESD protection (EGND)

The FPC2530 flex module is fitted with a conductive external bezel for improved appearance. The bezel is directly connected to the ESD drain node (EGND). The EGND and hidden bezel operation is described more in detail in the "LGA integration guideline" where both the use of underfill, and other things so consider when attaching an external bezel, are described. General reference schematic below.

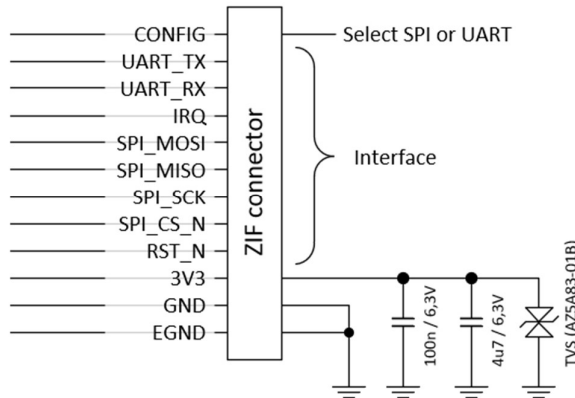

7.5 Mating connector

Several brands of flex connectors will successfully fit with the Biometric Systems module. On Fingerprints development boards, Molex 505110-1292 is used. Flex dimensions and connector solder pattern for this combination is shown below. Please refer to Molex data sheets for additional information.

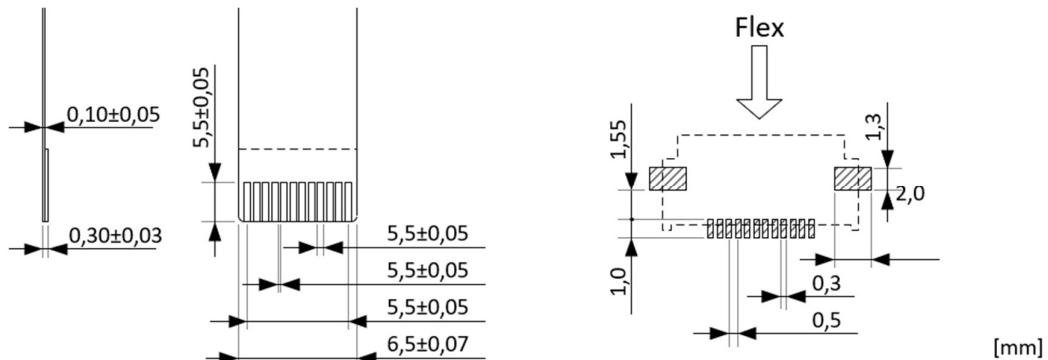

7.6 Water and dust proof

The Biometric module complies with the IP67 standard which means its water and dust proof, and not damaged by rain or splashing water. The internal sealing is accomplished by a sealing agent, filling the entire gap between solder joints and around the bezel. In order to create a water and dust proof end user product, the bezel flange needs to be fully sealed towards the product casing/enclosure, e.g. using Tesa 62625 or similar, to make a complete ring all around the bezel. Alternatively a full backside potting can be applied.

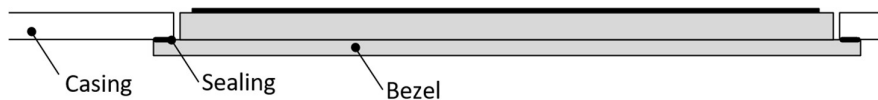



8 USER GUIDELINE

8.1 Introduction

Biometric systems are built to cope with variations in user behavior and different conditions. Understanding the basics of what will impact biometric performance, will help to improve product integration and system design. The coming sections describes the fundamentals of a biometric system. It's strongly recommended to avoid a product integration that impairs users' possibility to interact with the biometric system in an optimal way. Allowing for, or even encouraging correct finger placement, will in the end result in a stable high performing system.

8.2 Finger placement

Below is some general information on how to properly put a finger on a sensor. This behavior can be emphasized in the product design with a user-friendly approach angle, finger guidance, or symbols and signs.

- ⊗ The lower part of the fingertip should be exposed to the sensor
- ⊗ The sensor needs to be fully covered by the finger
- ⊗ Keep the finger straight and fully parallel to the sensor

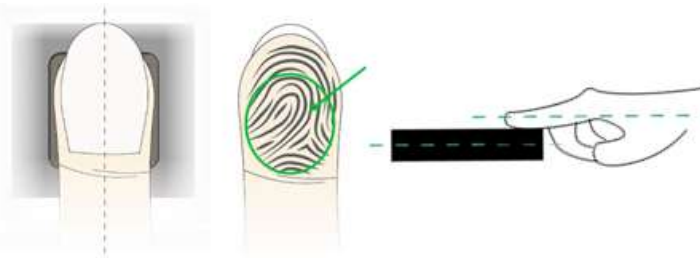

8.3 Enroll

Before first usage, at least one fingerprint needs to be registered, i.e. enrolled on the sensor. The enrollment information is stored as a template, containing key features in the fingerprint, and cannot be reversed to a fingerprint image. It's recommended that enrollment is done in the same way as normal product use will happen, i.e. wall mounted vs handheld, standing vs sitting etc. Below the enrollment process is described.

- ⊗ Approach the sensor as you would when using it (i.e. same placement, direction, grip)
- ⊗ Enroll the finger you want to use for verification
- ⊗ Keep the finger still on the sensor for approximately 1 second and then completely lift it
- ⊗ This must be repeated until the enrollment is finished, and a complete template has been acquired
- ⊗ To enroll additional fingers, restart the enrollment and repeat the process with another finger
- ⊗ The sensor needs to be fully covered by the finger

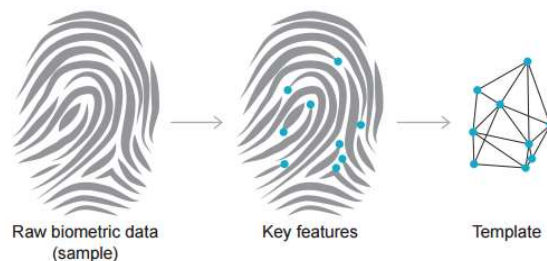



8.4 Verify/Authenticate

When the sensor is used to verify a user, features on the fingerprint presented are compared to features in the stored template. If there are enough similar features, it is considered a match. Once again, user repeatability should be encouraged by the design to maximize biometric performance.

- ⦿ Make sure you use the same finger as when you enrolled
- ⦿ And that preferably the same part of the fingertip is exposed to the sensor.

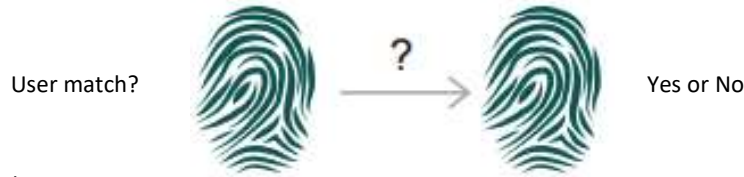

8.5 Template update

Template updating adapts the template information to better match seasonal variations and/or damages to the enrolled fingertip. Template updating is only activated for consecutive successful verifications.

Template updating enables:

- ⦿ Increased template information (template growing) to mitigate low initial fingerprint coverage
- ⦿ Increased quality score of already covered parts with successful matching
- ⦿ Adapting template information to variations in user behavior (new grip or approach)
- ⦿ Adapting template information to seasonal variations (e.g. humidity)
- ⦿ Adapting template information to fingertip degradation/improvement (e.g. worn or dry fingertip)

Template update use acquired template information to continuously improve the match score.

8.6 Biometric performance

An estimate on the biometric performance is given in the table below. Values are measured on a reference dataset. Individual performance may vary depending on user mobility, skin conditions, etc.

PARAMETER	USE CASE	VALUE	COMMENT
FRR (False Reject Rate)	After Enrollment	< 5 %	Normal dataset, measured directly after enrollment
	After Template Update	< 2 %	Normal dataset, measured after multiple updates
	Wet Fingers	< 8 %	Dataset with wet fingers, measured against normally enrolled fingers
FAR (False Accept Rate)	-	1 / 100 K	False Accept Rate is given per finger

8.6.1 Abbreviations

FAR (False Accept Rate): the probability that the system incorrectly matches the input pattern to a non-matching template in the database. It measures the percent of invalid inputs that are incorrectly accepted. In case of similarity scale, if the person is an imposter, but the matching score is higher than the threshold, then he is treated as genuine. This increases the FAR, which thus also depends upon the threshold value. FAR also increases with increased number of enrolled templates. In summary, FAR is a measurement on security.



FRR (False Reject Rate): the probability that the system fails to detect a match between the input pattern and a matching template in the database. It measures the percent of valid inputs that are incorrectly rejected. In summary, FRR is a measurement on convenience or user friendliness.

The errors that are observed in FRR are typically not evenly distributed between the users, most of the users have good biometric performance but few users might have an observed high FRR. The reason for this is that the fingers of the users with high FRR might have features that are hard to capture e.g. from worn fingers, dry skin, or damages

8.7 Navigation

The navigational gesture detection is designed to handle variations in user motion and classifying them accordingly. Just like biometrics, understanding how the system operates helps improve the performance even further.

The detection of gestures is primarily done through how the finger *leaves* the sensor. For example, if the top part of the sensor loses connection to the finger first, it is likely to be detected as a swipe downwards. If the finger is lifted straight from the sensor, it is considered a short press. If it stays on the sensor for longer, it is a long press.

The following guidelines helps achieve the best possible performance:

- ⊗ The sensor should be fully covered by the finger at some point during the gesture.
- ⊗ Keep the finger straight and fully parallel to the sensor.
- ⊗ For presses, lift the finger straight from the sensor.
- ⊗ For swipes, make a clear sweeping motion in the intended direction.
- ⊗ Sweep across the entire sensor, starting at one edge and ending past the opposite edge.



9 DEVELOPMENT BOARDS

To support integration and development of the target application, Fingerprints provides different breakout boards and development kits. Development boards are available to support both the Feather wing and Arduino Shield standard.

9.1 FingerWing - Sensor feather wing

9.1.1 Overview

The FingerWing is a Biometric Systems breakout board, with all LGA signals easily accessible via through-hole-plated connections. The FingerWing can be used either by attaching cables directly to the board, or by connecting to the standard 12 and 16 pin feather board headers (mounted on delivery). There is also a separate row of connections to mate with various FTDI based adapter boards.

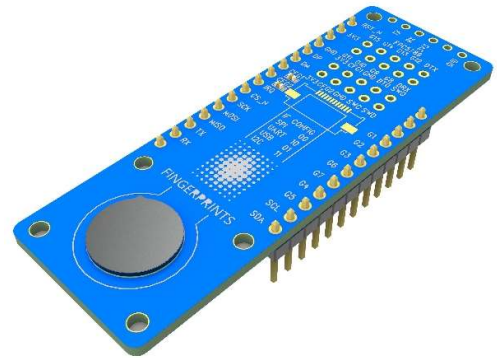

9.1.2 Product outline

All dimensions are according to the feather wing standard, except for the length where adjustments have been made to make sure that the sensor is easily accessible to the user, without touching any electrical signals. All mounting holes, with break-out signals, are placed in a 2,54 mmm grid, allowing for an easy connection with standard proto boards.

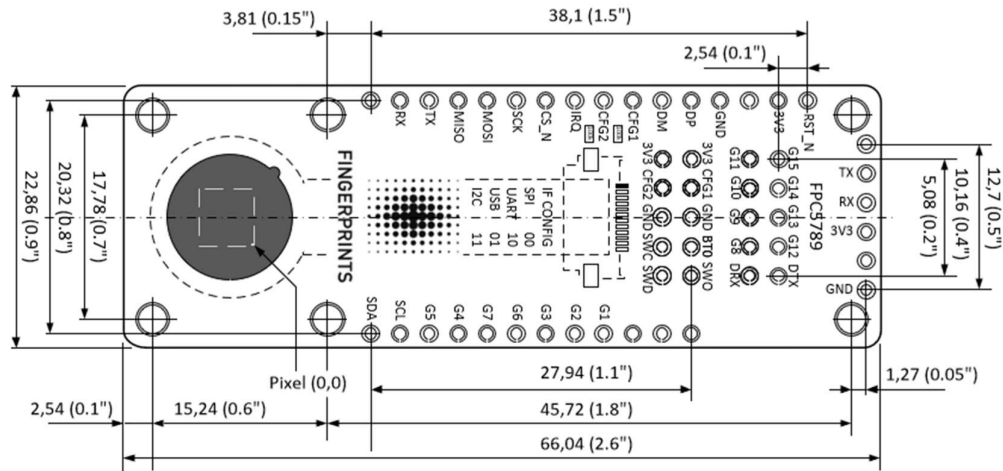



9.1.3 Simplified schematic

All signals from the LGA are available in one or more headers in order to support the feather wing standard as well as commonly used USB to UART adaptors (FTDI). Remaining signal are made available in the two 10p breakout headers (not mounted). To simplify onboard interface selection, CFG1 and CFG2 are also available in the breakout header close by 3V3 and GND. Note that these two signals (CFG1* and CFG2*) are connected to the corresponding CFG1 and CFG2 in the FingerWing header via 100k resistors. This to avoid signal shortage, if SW settings are accidentally applied on top of a manual interface selection.

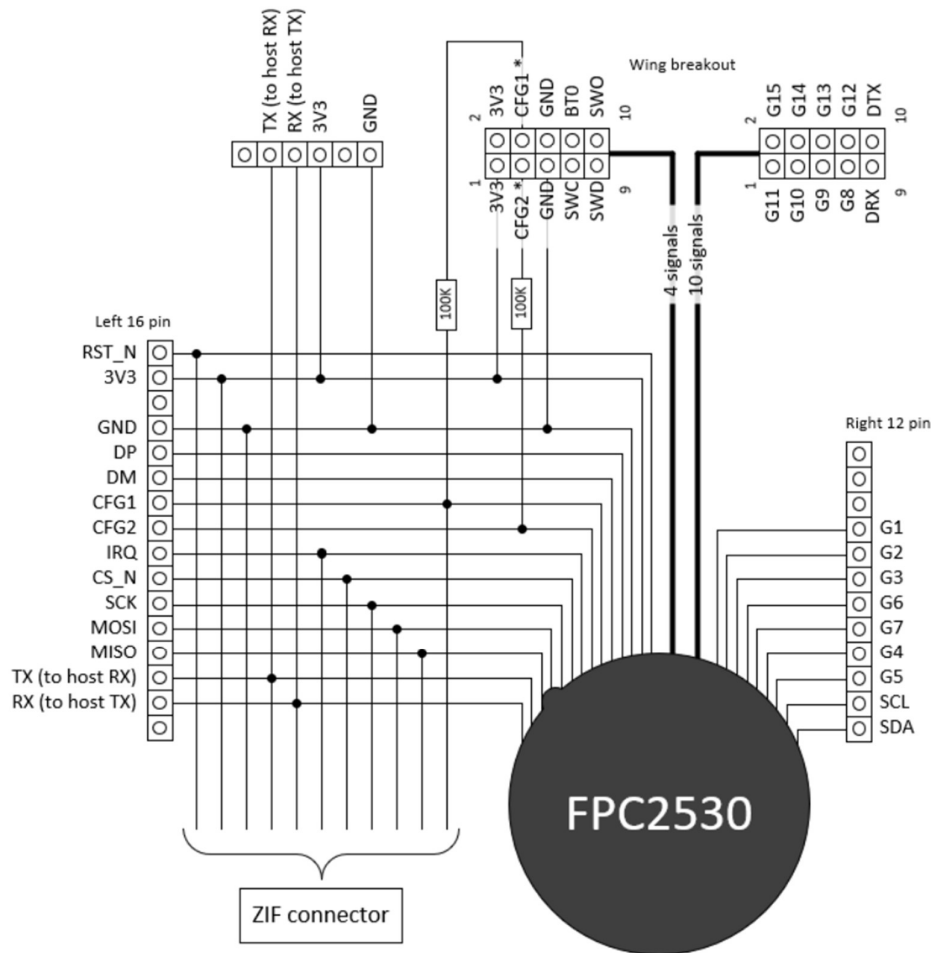



9.1.4 Pin configuration

Most pins on the LGA or module are directly connected to the wing headers and hence a detailed description of the signals is be found earlier in the document.

FingerWing headers (16 pin / 12 pin):

PIN	NAME (short)	FULL SIGNAL NAME
1	RST_N	RST_N
2	3V3	3V3
3	Not used	Not used
4	GND	GND
5	DP	USB_DP
6	DM	USB_DM
7	CFG1	IF_CFG_1
8	CFG2	IF_CFG_2
9	IRQ	IRQ
10	CS_N	SPI_CS_N
11	SCK	SPI_SCK
12	MOSI	SPI_MOSI
13	MISO	SPI_MISO
14	TX	UART_TX (to host RX)
15	RX	UART_RX (to host TX)
16	Not used	Not used

PIN	NAME (short)	FULL SIGNAL NAME
-		
-		
-		
-		
1	Not used	
2	Not used	
3	Not used	
4	G1	GPIO_1
5	G2	GPIO_2
6	G3	GPIO_3
7	G6	GPIO_6
8	G7	GPIO_7
9	G4	GPIO_4
10	G5	GPIO_5
11	SCL	I2C_SCL
12	SDA	I2C_SDA

Breakout headers (10 pin / 10 pin):

PIN	NAME (short)	FULL SIGNAL NAME
1	3V3	3V3
2	3V3	3V3
3	CFG1 *	
4	CFG2 *	
5	GND	GND
6	GND	GND
7	SWC **	DBG_SWCLK
8	BT0	BOOT0
9	SWD **	DBG_SWO
10	SWO **	DBG_SWDIO

PIN	NAME (short)	FULL SIGNAL NAME
1	G11	GPIO_11
2	G15	GPIO_15
3	G10	GPIO_10
4	G14	GPIO_14
5	G9	GPIO_9
6	G13	GPIO_13
7	G8	GPIO_8
8	G12	GPIO_12
9	DRX **	DBG_UART_RX
10	DTX **	DBG_UART_TX

(*) NOTE: CFG1 and CFG2 in the breakout header above, are connected to CFG1 and CFG2 in the Feather wing header via 100k resistors, to avoid signal shortage if SW settings are accidentally applied on top of a manual interface selection.

(**) NOTE: DBG signal are only for internal use, leave not connected



Serial adapter board interface:

PIN	NAME (short)	FULL SINGAL NAME
1	Not used	
2	TX	UART_TX (connect to host RX)
3	RX	UART_RX (connect to host TX)
4	3V3 *	
5	Not used	
6	GND	

(*) NOTE: Only serial adapter boards, or cable assemblies, supporting 3V3 supply voltage can be used. Connecting a 3V3 serial adapter with 5V power supply may damage the FPC2530 device.

Flex connector pattern:

The FingerWing is prepared for a flex connector (option). But this is not mounted on delivery since the LGA, and the flex connector, cannot be attached at the same time (signal shortage). If the FingerWing is to be used with a flex connector and module, the LGA need to be "not mounted". Refer to the "Customization" section to understand more about available options.

9.1.5 Interface selection

Interface configuration can be set in SW or manually (hard wired) on the feather wing with wire jumpers. Correct configuration for each interface is described in the "LGA integration guideline" section. If they are left open (not set), SPI is the default interface. No wire jumpers are mounted on delivery. If the FingerWing is used together with a shield board, manual configuration can also be done directly on the shield.

SPI interface set:

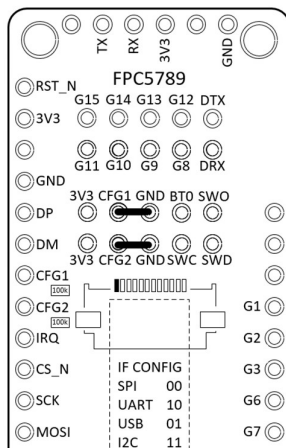

UART interface set:

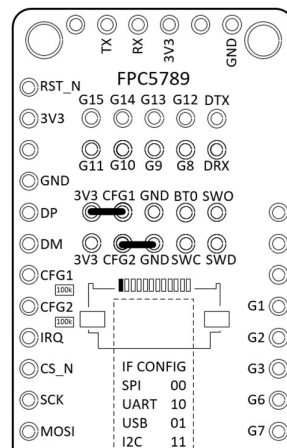



9.2 Shield - Arduino shield board

9.2.1 Overview

The shield board provides connection to the biometric FingerWing, the Arduino shield connector interface, and to the flex module. The shield also provides access and configuration possibilities to all signals available on the FPC2530 Biometric system. Even though many signals are placed for easy configuration with a jumper, all signals are fully flexible, and the final shield configuration is decided by the customer. The FingerWing is attached on top of the shield.

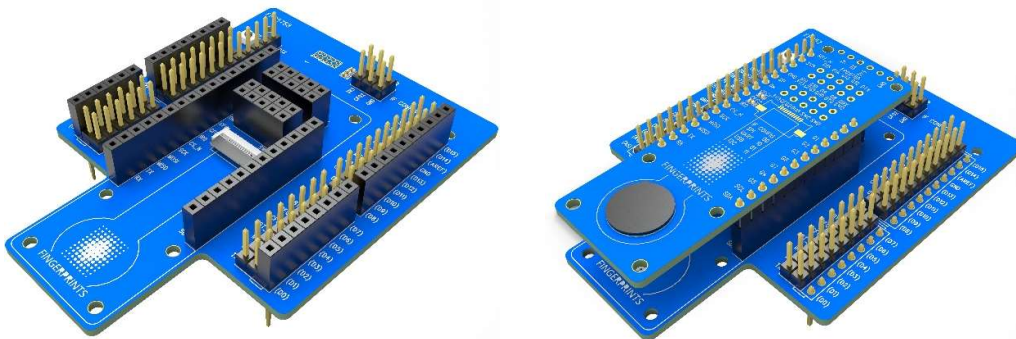

9.2.2 Shield default setup

On delivery the shield is setup to work with the Fingerprints example code. Other configurations are possible, but the jumper setting to the right is default.

Pay attention to connect the 3V3_IN to 3V3 and GND jumper since this jumper provides power and ground to the entire board. The 5V_IN is NOT to be used and may damage the FPC2530 if connected.

9.2.3 DEEP SLEEP wakeup in UART mode

The steps to wake up a Biometric system from DEEP SLEEP in UART mode, is described more in detail under the "Interface/UART communication" section.

As described in the above-mentioned section, if no separate signal is assigned as system wakeup, a dedicated jumper is required between CS_N (SYS_WU in UART mode) and UART_RX. This will allow the system to wake up using only the UART_RX signal.

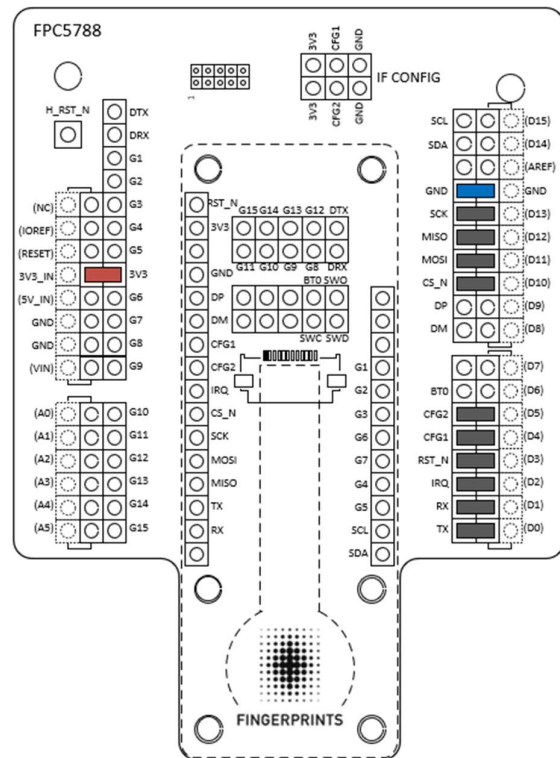
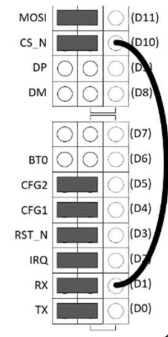



9.2.1 Product outline

All dimensions are according to the normal shield standard. All mounting holes, including break-out signals, are placed in a 2,54 mm grid, allowing for an easy connection with standard proto boards.

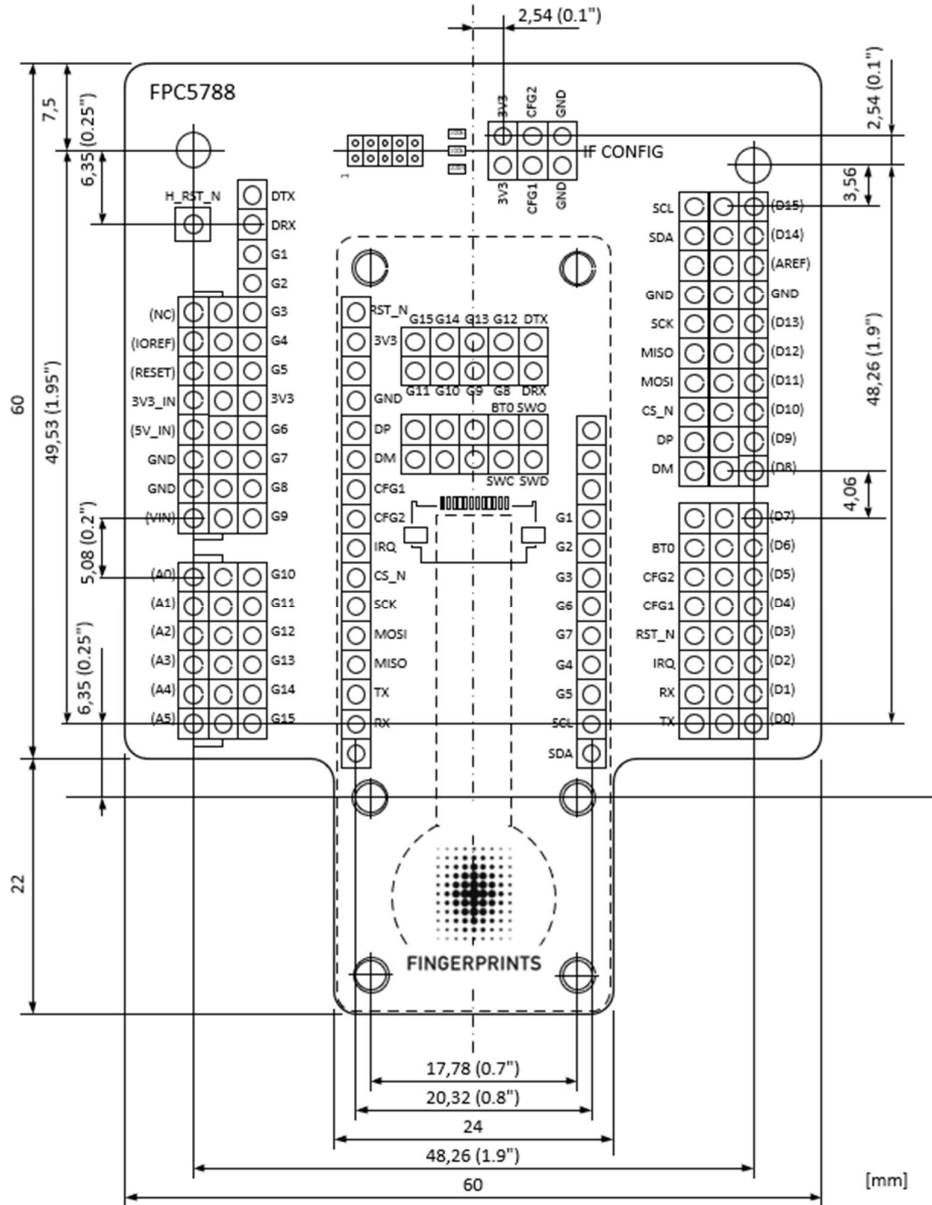



9.2.2 Simplified schematic

All signals coming from the FingerWing are available in headers for easy configuration in the shield interface. To simplify onboard interface selection, CFG1 and CFG2 are also available in a separate header close by 3V3 and GND. Note that these two signals (CFG1* and CFG2*) are connected to the corresponding CFG1 and CFG2 in the shield configuration header via 100k resistors. This to avoid signal shortage, if SW settings are accidentally applied on top of a manual interface selection. Besides headers there is also a system reset micro switch (RST_N) available in the top left of the board. Pressing this one will send a reset signal to the FPC2530.

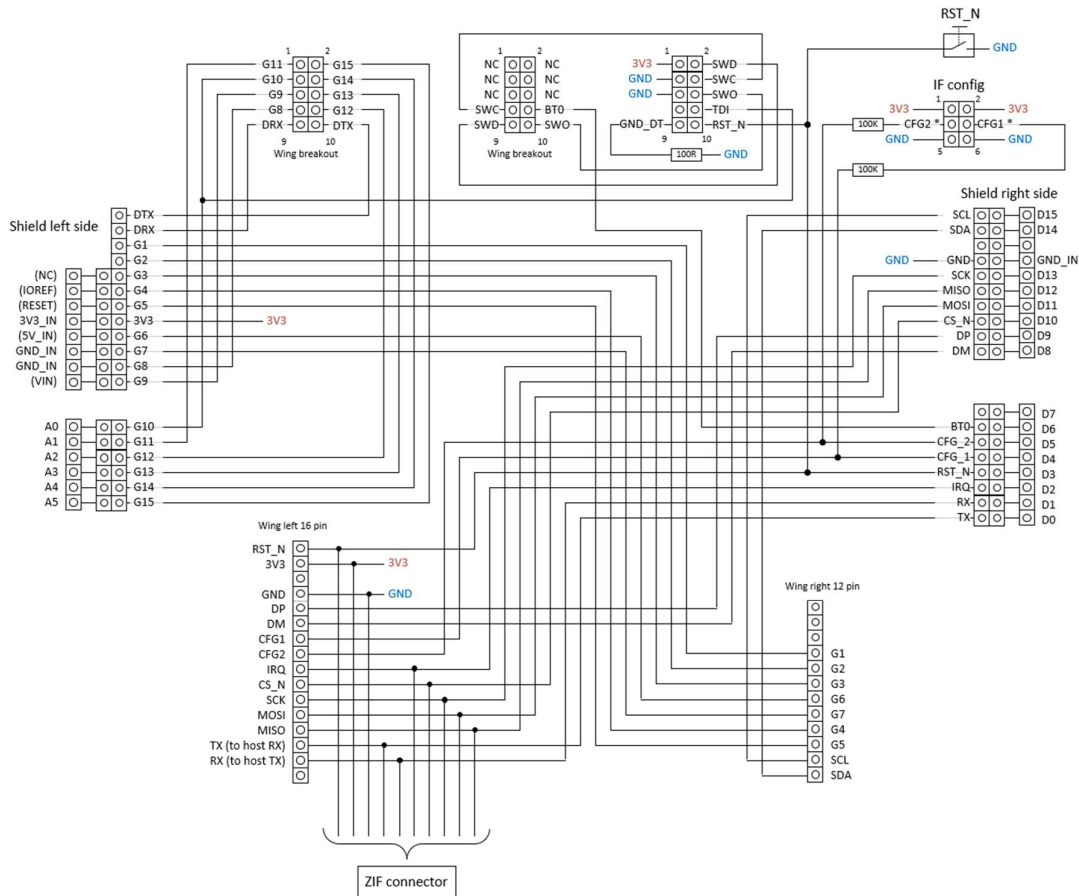



9.2.3 Pin configuration

Headers with signals coming from the FingerWing are described in the FingerWing section. The four shield headers are built up of three columns, the outer header column represents the standard stackable shield header, center column is one-to-one connected with the first one mounted on the top side facing up. The last column, towards board center, contains signals from the FingerWing and can hence easily be connected to the neighboring shield pin with a jumper, or further away using a jumper cable. Shield interface signals in brackets are not used in this board setup and should not be connected with jumpers.

Left shield headers (top side signals only):

POS	CENTER Shield signal	RIGHT COL Wing signal	NOTE
1		DTX	Internal use only
2		DRX	Internal use only
3		G1	GPIO_1
4		G2	GPIO_2
5	(NC)	G3	GPIO_3
6	(IOREF)	G4	GPIO_4
7	(RESET)	G5	GPIO_5
8	3V3_IN	3V3	Shield power supply
9	(5V_IN)	G6	GPIO_6
10	GND	G7	GPIO_7
11	GND	G8	GPIO_8
12	(VIN)	G9	GPIO_9
13	A0	G10	GPIO_10
14	A1	G11	GPIO_11
15	A2	G12	GPIO_12
16	A3	G13	GPIO_13
17	A4	G14	GPIO_14
18	A5	G15	GPIO_15

Right shield headers (top side signals only):

POS	CENTER Shield signal	LEFT COL Wing signal	NOTE
1			
2	D15	SCL	I2C_SCL
3	D14	SDA	I2C_SDA
4	(AREF)	Not used	
5	D13	SCK	SPI_SCK
6	D12	MISO	SPI_MISO
7	D11	MOSI	SPI_MOSI
8	D10	CS_N	SPI_CS_N
9	D9	DP	USB_DP
10	D8	DM	USB_DM
11	D7	Not used	
12	D6	BT0	Internal use only
13	D5	CFG2	IF_CFG_2
14	D4	CFG1	IF_CFG_1
15	D3	RST_N	System reset
16	D2	IRQ	Interrupt request
17	D1	RX	To host TX
18	D0	TX	To host RX

9.2.4 Interface selection

Interface configuration can be set in SW or manually on the shield using jumpers. Correct configuration for each interface is described in the "LGA integration guideline" section. If they are left open (not set), SPI is the default interface. Also pay attention to any hard-wired interface selection done on the FingerWing. Conflicting interface selection will lead to interface malfunction.

SPI interface set:

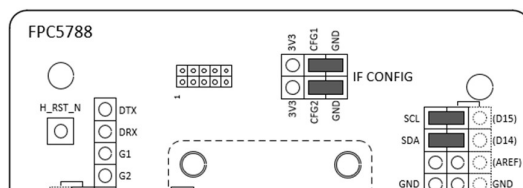

UART interface set:

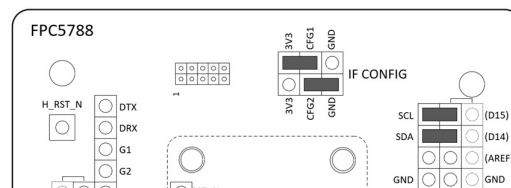



2024-11-12

FPC AllKey - Biometric System family

9.3 Flex (12p) breakout board

9.3.1 Overview

The flex breakout board is provided to simplify initial module evaluation and early prototyping. All pins are exposed for easy access. On top of this interface selection can be hardwired directly on the breakout board as well as EGND and GND connection.

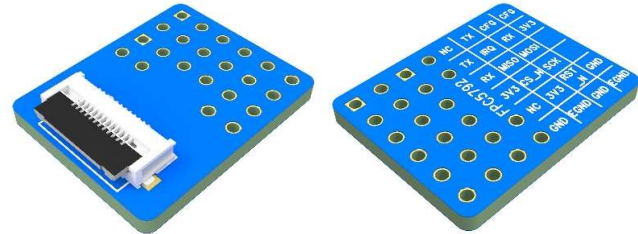

9.3.2 Product outline

On delivery the breakout board is provided with a ZIF connector only. Remaining terminals are left open and ready for connection to serial adapters or pin-to-pin wiring.

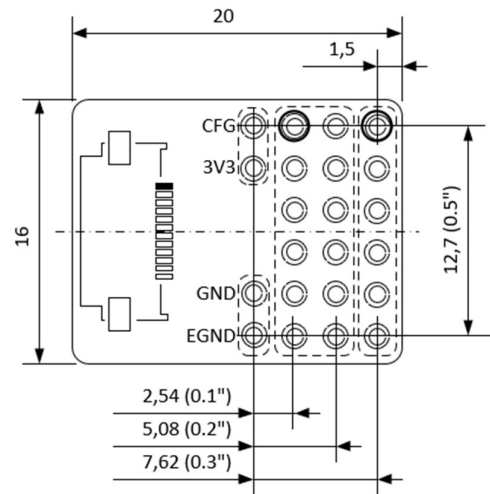

9.3.3 Simplified schematic

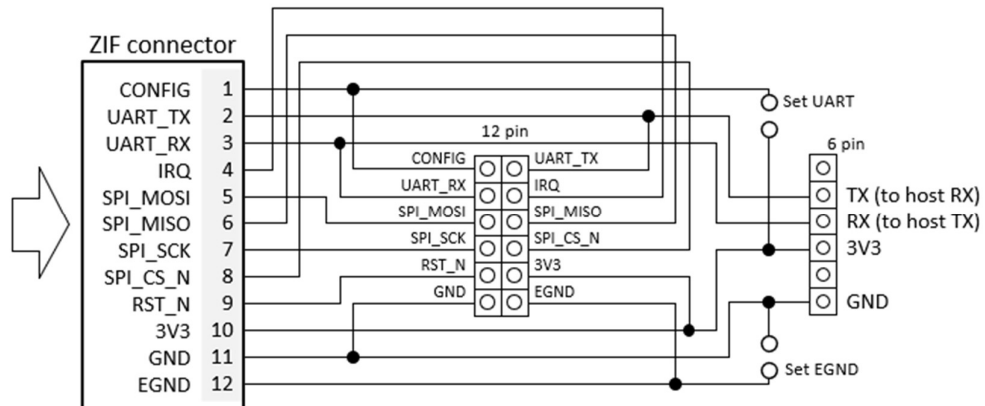



9.3.4 Pin configuration

Flex breakout board header (4x6 matrix):

SETUP COLUMN	BREAKOUT 1 (left)	BREAKOUT 2 (right)	SERIAL ADAPTOR
CFG	CONFIG (PIN 1)	UART_TX (PIN 2)	NC (PIN 1)
3V3	UART_RX (PIN 3)	IRQ (PIN 4)	TX (PIN 2)
-	SPI_MOSI (PIN 5)	SPI_MISO (PIN 6)	RX (PIN 3)
-	SPI_SCK (PIN 7)	SPI_CS_N (PIN 8)	3V3 (PIN 4)
GND	RST_N (PIN 9)	3V3 (PIN 10)	NC (PIN 5)
EGND	GND (PIN 11)	EGND (PIN 12)	GND (PIN 6)

TOP VIEW / SERIAL ADAPTER INTERFACE

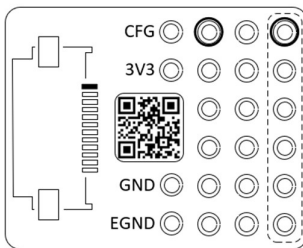

TOP VIEW / FLEX BREAKOUT PINS

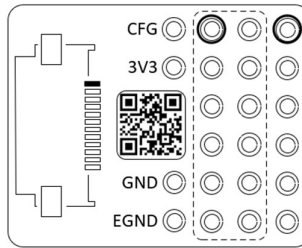

BOTTOM VIEW

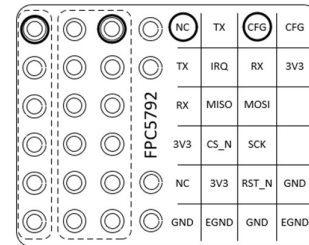

9.3.5 Interface selection and ESD discharge path

Interface configuration can be set in SW or manually (hard wired) on the flex breakout board with a wire jumper. To use UART the jumper need to be set, if the jumper is left open SPI is the default interface. No wire jumpers are mounted on delivery.

More information on setting the correct configuration for each interface is described in the “LGA integration guideline” section.

If an external protective ground is available, EGND can be connected directly to this terminal. Otherwise EGND should be shorted to GND. Note the EGND should not be left open (not connected) since this will disable the built-in ESD discharge protection.

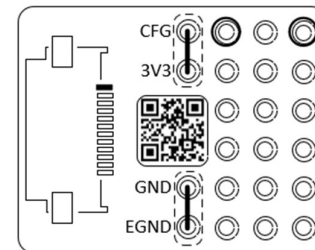
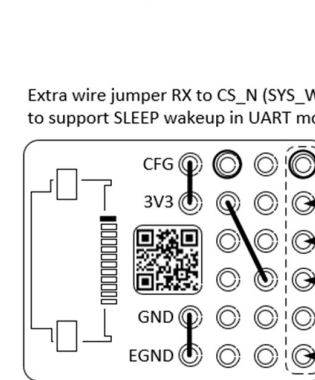
Wire jumper to set UART
SPI is default if left openWire jumper to short
EGND to GNDExtra wire jumper RX to CS_N (SYS_WU)
to support SLEEP wakeup in UART mode

9.3.6 DEEP SLEEP wakeup in UART mode

The steps to wake up a Biometric system from DEEP SLEEP in UART mode, is described more in detail under the “Interface/UART communication” section.

As described in the above-mentioned section, if no separate signal is assigned as system wakeup, e.g. using a common USB-to-serial adaptor, a dedicated jumper is required between CS_N (SYS_WU in UART mode) and UART_RX. This will allow the system to wake up using only the UART_RX signal.

**10 PRODUCT STRESS TESTING**

10.1 Standard compliance - LGA package

The FPC2530 LGA package is tested according to the JEDEC standard. Below performed tests are listed.

TEST ITEM	CONDITION	RESULT
Preconditioning (PC)	MSL3	PASS
Temperature cycling (TCT)	-55°C to 125°C, 700x, 2 cycles/hour	PASS
Unbiased HAST	130°C, 85% RH, 96 hours	PASS
High temp storage (HTSL)	150°C, 1000 hours	PASS

10.2 Standard compliance - Flex module

The FPC2530 module is tested according to applicable standards. Below performed tests are listed.

TEST ITEM	CONDITION	RESULT
IP67	SS-EN 60529, IP6X and IPX7	PASS
Thermal shock	30 cycles (-40°C 2 hours ~85°C 2 hours, 5 min duration at 20°C between), 4 hours at room temperature	PASS
High temperature high humidity	T85°C/RH85%/120 hours, 4 hours at room temperature	PASS
Low temperature storage	120 hours, -40°C	PASS
Ball drop test	Basic requirement: 18mm stainless steel ball, minimum 5cm height	PASS
Static load	3mm round tip (material SUS), increased load up to 13 kgf, Speed 5mm/min, hold 10sec, repeat 10 times	PASS
Flex bending Test	Bending fixture: R=0.8mm, thickness= 1mm, bending 180° for 20 times	PASS
ESD contact discharge	IEC61000-4-2, 8 kV	PASS
ESD air discharge	IEC61000-4-2, 15 kV	PASS



10.3 Sensor surface properties

The FPC2530 surface coating is tested according to Fingerprints internal test methods. No formal standard applies but the listed test items below have proven to be adequate to guarantee good biometric performance.

TEST ITEM	DESCRIPTION	RESULT
Coating thickness	Manual thickness measurement before and after coating	PASS
Coating adhesion	1mm cut, 3 times tape, classification: max 2 (ISO 2409)	PASS
Coating WCA	Water Contact Angle > 75°	PASS
Pencil hardness	ISO 15184-2012 classifications: 4H	PASS
UV resistance	Distance between Lamp and Samples: 200mm, test UVB only, Lux value 15W for 72 hours	PASS
RCA paper abrasion test	175g load, 80 times, 17cycles/min	PASS
Hot water resistance	30 min 80°C, wipe dry	PASS
Salt spray resistance	Surface continuous sprayed with salt solution, 35°C, 72h 5%±1% Na Cl, PH=6.5~7.2	PASS
Alcohol resistance	500g load, 250 strokes (40 strokes/min), alcohol input: 1 ml/50 strokes and then perform cross-cutting	PASS
Ink resistance	Pen lines on surface T85 °C/RH 85%/60 min, room temperature 60 min, cleaning 15 times, 2 kg load using 99.3% alcohol cloth	PASS
Artificial sweat test	SHINYO BUFFER STD SOLUTION pH4, pH7(48 hours), wash with water, wipe dry, 4 hours in room temperature	PASS
Cosmetics resistance	Sunblock cream on surface, T85°C/RH85%/24h, wash with water, wipe with cloth	PASS



11 ENVIRONMENTAL COMPLIANCE

11.1 Environmental regulations

The FPC2530 device family all comply with the necessary regulations.

TEST ITEM	CONDITION	RESULT
RoHS EU	Compliant to requirement standard	PASS
RoHS China	Compliant to requirement standard	PASS
REACH	Compliant to requirement standard	PASS
Halogen free	Compliant to requirement standard	PASS
ODS	Compliant to requirement standard	PASS
POP	Compliant to requirement standard	PASS
Conflict minerals	Compliant to requirement standard	PASS



12 CUSTOMIZATION (ON REQUEST)

12.1 Customization project

The FPC2530 can be customized in many ways to fit specific target applications. Both host-controlled systems, as well as stand-alone operation mode without external components can be supported. Depending on the level of customization different MOQ (minimum order quantity), NRE (non-refundable engineering fee) and lead time will apply. Reach out to your FPC sales contact for more information on customization projects.

12.2 Device geometry

FPC2530 is available off-the-shelf in a standard sized LGA. On request other dimensions, colors and/or shapes can be provided.

Available size ranges that can be supported on request:

- ⊗ Round 11,0 to 13,2 mm
- ⊗ Square 9,0 to 13,2 mm
- ⊗ Larger sizes are also possible but with longer lead time

12.3 General purpose IO

The FPC2530 family are equipped with multiple GPIO signals for controlling peripherals or communicating with external host systems. In some product versions the GPIOs have dedicated functionality, in others they are not used. Due to the vast number of interfaces and onboard GPIO possibilities, the FPC2530 device can be customized to fit into numerous target applications.

Example of functionalities that can be supported on request:

- ⊗ Additional SPI busses or UART communication
- ⊗ LED control (RGB/PWM)
- ⊗ External oscillator
- ⊗ ADC and/or DAC
- ⊗ Digital audio
- ⊗ SD memory cards



13 ORDERING INFORMATION

13.1 Device name and Part numbers

PRODUCT	PART #	DESCRIPTION
FPC2532AP	100026222	47 pin LGA, FPC AllKey package
FPC2534AP	100026223	47 pin LGA, FPC AllKey Pro package
FPC2532AM	100026207	12 pin AllKey flex module including FPC2532AP (UART and SPI, black bezel)
FPC2534AM	100026230	12 pin AllKey Pro module including FPC2534AP (UART and SPI, black bezel)
AllKey Devkit	100026231	FingerWing including FPC2532AP mounted on the Shield
AllKey Pro Devkit	100026232	FingerWing including FPC2534AP mounted on the Shield
FPC5792	100026229	Flex break-out, 12 pin ZIF with interface selection

13.2 Production codes

All LGA parts are laser marked on the backside with a unique production code. This code comprises information about part number, production batch and date.

ITEM	REFERENCE DESIGNATION	LENGTH
Part number	NNNNNNNN (FPC part number)	9 characters
Supplier batch number	BBBBBB (example S29227)	6 characters
Lot number	C	1 character
Manufacturing year	YY	2 characters
Manufacturing week	WW	2 characters

Other devices are labeled with a QR code instead.

ITEM	REFERENCE DESIGNATION	LENGTH
Part number	NNNNNNNN (FPC part number)	9 characters
Hardware revision	1A	2 characters
Supplier batch number	DDDDDDDDDD (up to)	12 characters
Manufacturing year	YY	2 characters
Manufacturing week	WW	2 characters

Example QR code string: 100026224-1A-DDDDDDDD-2418



13.3 Shipping format

AllKey LGA parts are supplied face up in standard ESD safe JEDEC trays, 144 sensor units per tray. Products are arranged in trays to match standard industry; pin 1 at the tray chamfered corner. 10 trays and one lid are stacked, wrapped, and dry packed in one ESD safe bag, i.e. 1440 parts per full stack/box, all placed in a standard cardboard box (tray box).

AllKey modules are supplied in ESD safe vacuum trays, 60 units per tray, 10 trays per box.

Boxes are marked with necessary product information, both text and barcode.

13.4 ESD sensitive device

Although the component provides a rigorous ESD protection when connected in the final application, proper handling shall be ensured during device assembly.



14 REVISION HISTORY

14.1 Product specification (this document)

REVISION	DESCRIPTION	RELEASE DATE
A	Initial release (draft) to support early engineering samples (ES)	Aug 2024
B	Final release (CS)	Nov 2024

14.2 Product updates

PRODUCT	REVISION	UPDATES	RELEASE DATE
FPC2532AP	1	Engineering sample release (ES)	Aug 2024
FPC2532AP	3	Customer sample release (CS), MP release	Nov 2024

15 CONTACT INFORMATION

Fingerprint Cards AB

Main office
P.O. Box 2412
SE-403 16, Gothenburg
Sweden

Web site
www.fingerprints.com

Sales contact information: sales@fingerprints.com

Mouser Electronics

Authorized Distributor

Click to View Pricing, Inventory, Delivery & Lifecycle Information:

[Fingerprints:](#)

[100026231](#) [100026222](#) [100026207](#) [100026223](#) [100026230](#) [100026232](#)