

EVALUATION BOARD MANUAL

EBSPBN Series

EVALUATION KIT MANUAL

EKSPBN Series

for EYSPBN Series Bluetooth[®] low energy Module

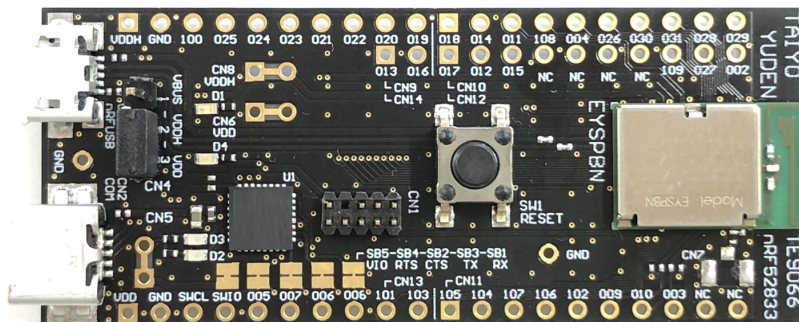

EBSPBN, EKSPBN

TAIYO YUDEN CO., LTD.

Introduction

This evaluation board is applicable for Taiyo Yuden's **Bluetooth® low energy** module, EYSPBN Series.

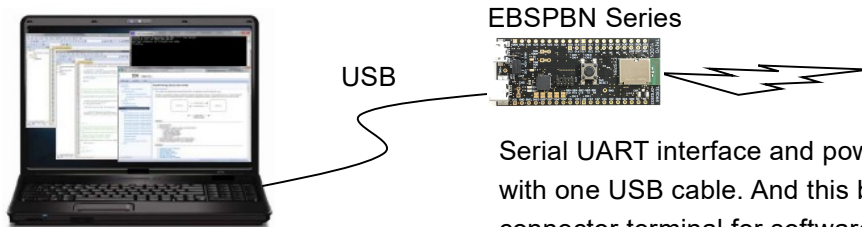

Serial UART interface and power supply are possible with one USB cable. And this board has the SWD connector terminal for software development.

Mounted module

EYSPBN (10.0mm x 15.4mm x 2.0mm_MAX)

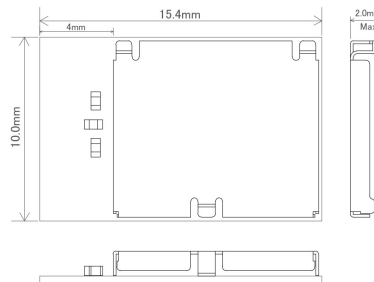
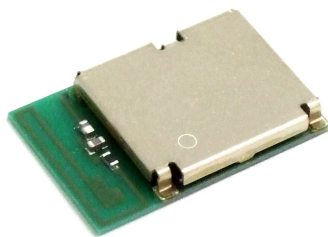

Nordic nRF52833 / ARM® Cortex™-M4F 32 bit processor and 512kB Flash & 128kB RAM
63-pin Land Grid Array / 40GPIOs / SWD

- Basic Module -

Taiyo Yuden writes firmware for S140 (EYSPBNZUA) SoftDevice to this product.

The user can develop unique application for the module.

Content

1	EBSPBN Series Evaluation Board	1 pc
2	J-Link Lite (EKSPBN Series Only) + USB cable for Evaluation Board	1 set

1. EBSPBN

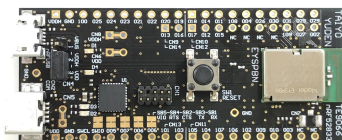

2. EKSPBN



TAIYO YUDEN CO., LTD

EBSPBN, EKSPBN

TAIYO YUDEN CO., LTD.

Evaluation board circuit schematic

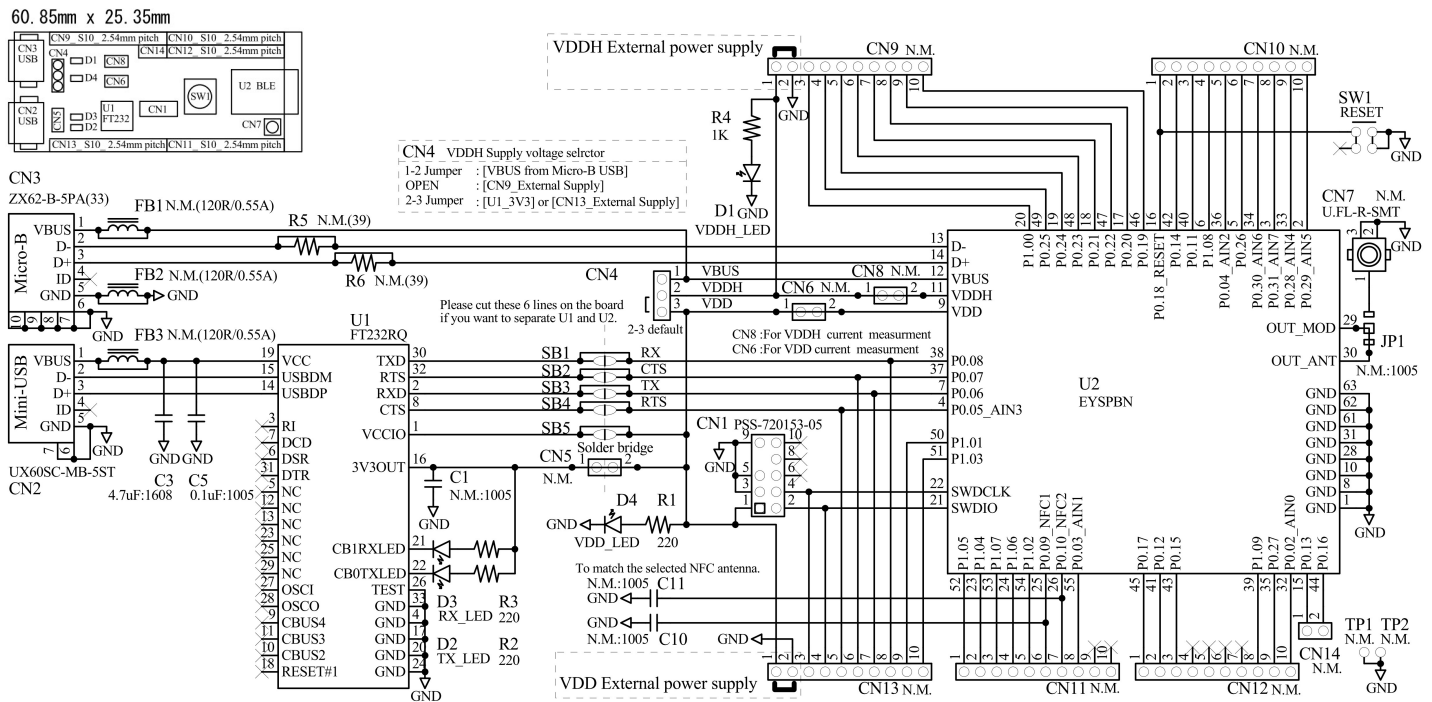

Evaluation board layout

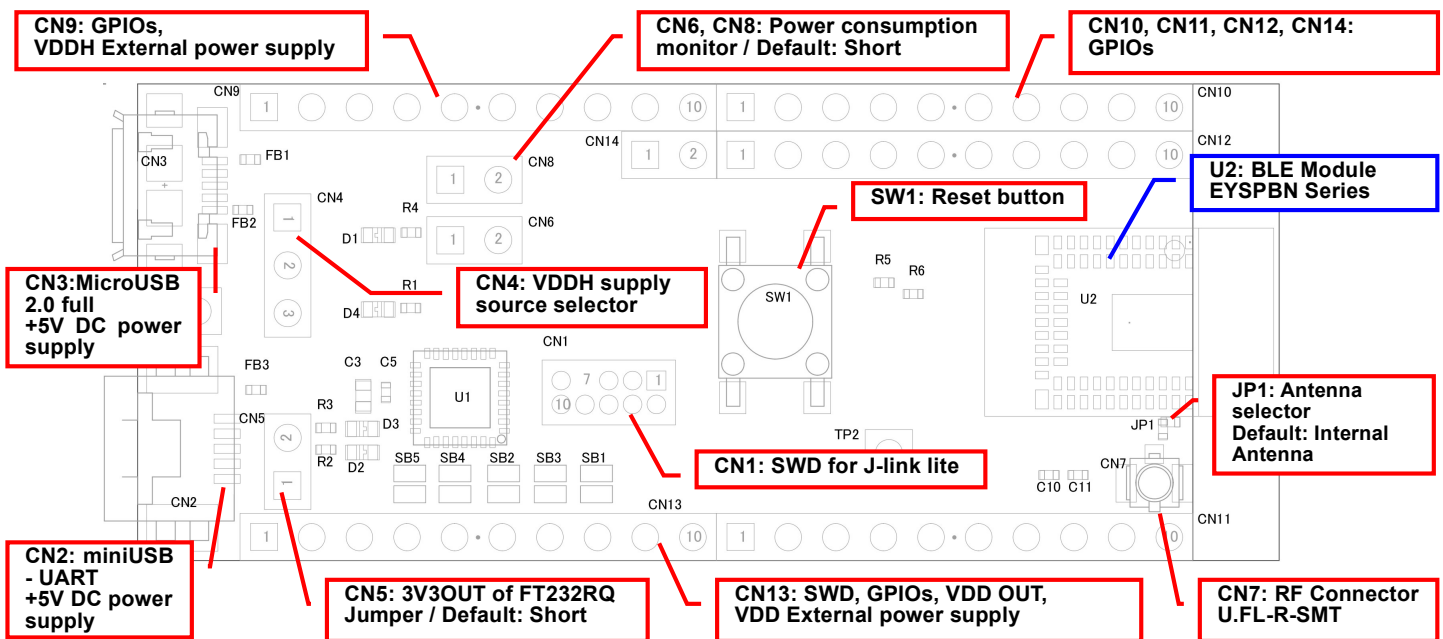

- 1) All pin headers are 2.54mm pitch. And **CN9 - CN14** are on the **2.54mm grid**.
- 2) Many parts are not mounted. Please refer to (N.M.) in the circuit schematic.
- 3) **D1 (LED)**: VDDH Indicator, **D4(LED)**: VDDL(VCC_NRF) Indicator
- 4) **D2 (LED)**: UART TX Indicator
- 5) **D3 (LED)**: UART RX Indicator
- 6) **SW1 (Push button)**: Module Reset (active low)

TAIYO YUDEN CO., LTD

EBSPBN, EKSPBN

TAIYO YUDEN CO., LTD.

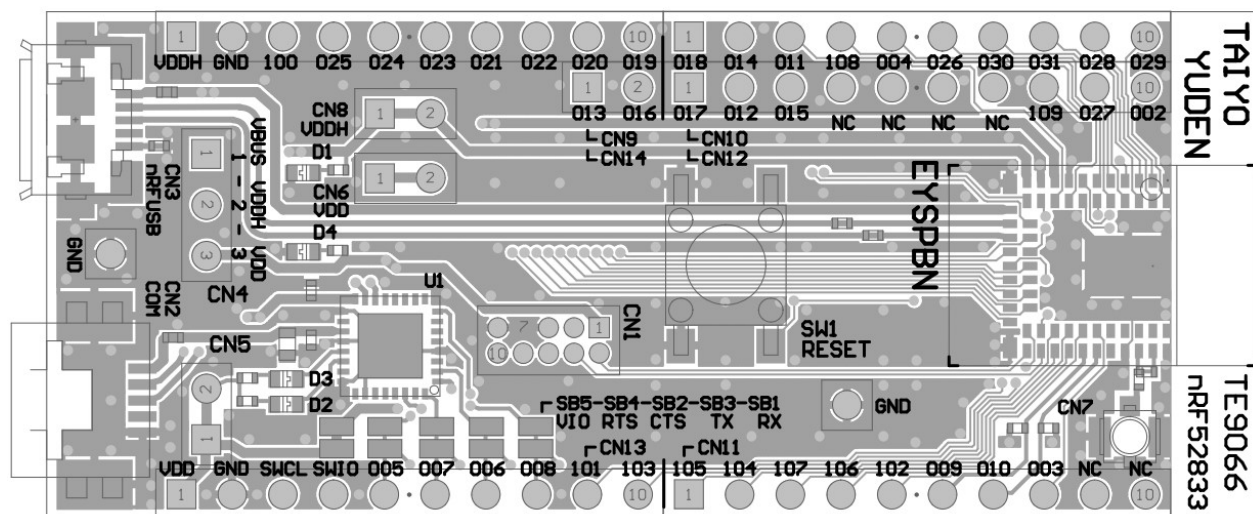
Silkscreen PrintingPin Descriptions

Pin No.	CN9	CN10	CN11
1	VDDH	P0.18_RESET	P1.05
2	GND	P0.14	P1.04
3	P1.00	P0.11	P1.07
4	P0.25	P1.08	P1.06
5	P0.24	P0.04_AIN2	P1.02
6	P0.23	P0.26	P0.09_NFC1
7	P0.21	P0.30_AIN6	P0.10_NFC2
8	P0.22	P0.31_AIN7	P0.03_AIN1
9	P0.20	P0.28_AIN4	N.C.
10	P0.19	P0.29_AIN5	N.C.

Pin No.	CN12	CN13	CN14
1	P0.17	VDD	P0.13
2	P0.12	GND	P0.16
3	P0.15	SWDCLK	
4	N.C.	SWDIO	
5	N.C.	P0.05_AIN3 / RTS	
6	N.C.	P0.07 / CTS	
7	N.C.	P0.06 / TX	
8	P1.09	P0.08 / RX	
9	P0.27	P1.01	
10	P0.02_AIN0	P1.03	

TAIYO YUDEN CO., LTD

EBSPBN, EKSPBN

TAIYO YUDEN CO., LTD.

How to use

It is very easy just to tie this board to the PC with a USB cable. It is not necessary to change the setting of the board. The power supply of the module supplies by default 3.3V from 3V3OUT of FT232RQ.

For software development

Nordic-DK and Use case

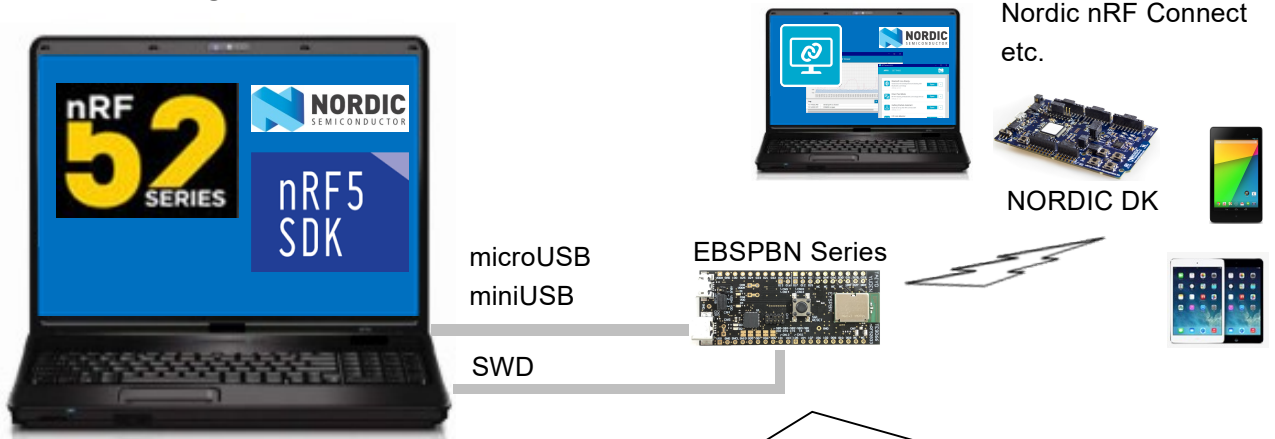

- SEGGER Embedded Studio



- nRF Connect for Desktop

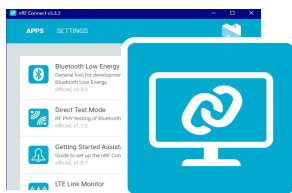

etc.

Nordic-nRF52833 DK

<https://www.nordicsemi.com/Products/Low-power-short-range-wireless/nRF52833>

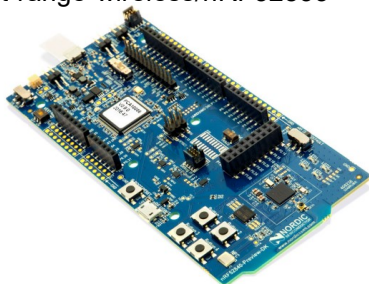

SWD : Serial Wire Debug

For example, please use J-Link Lite CortexM-9 JTAG/SWD Emulator.

EKSPBN included



CN1 supports the connection of the 10 pin 1.27mm flat cable.

Please be careful about the directions.

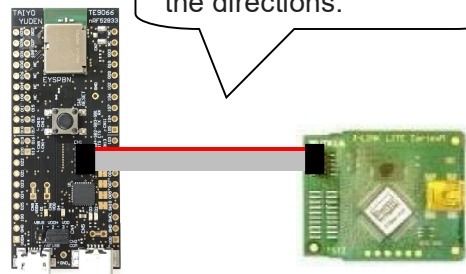

MEMO

1) Current measurement

To measure VDD current, please cut the shorting 1pin and 2 pin of CN6. And connect an ampere-meter between the pins of connector CN6 to monitor the current directly.

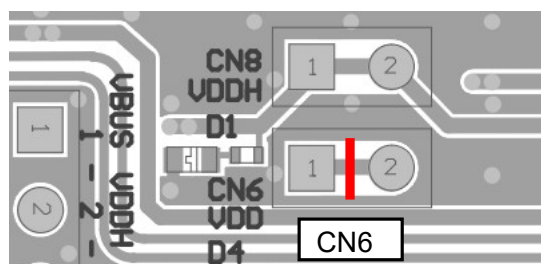

2) About VDD power supply

When you use external power supply, please supply power from 1pin and 2pin of CN13. On this case, you cut short circuit 1pin and 2pin of CN5 and should separate 3V3OUT of FT232RQ.

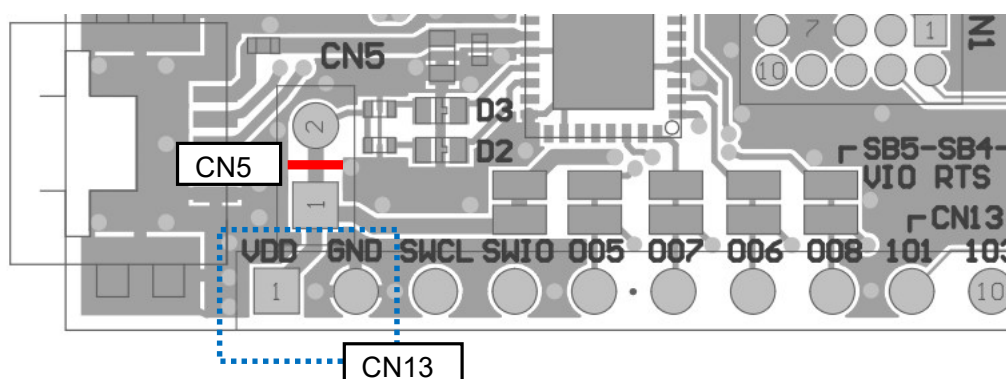

3) USB to serial UART interface

It needs to install driver of FT232RQ to use USB for UART interface. The drivers are available on FTDI website.

<http://www.ftdichip.com/Drivers/D2XX.htm>

In addition, by the application development, please assign GPIO as follows.

GPIO	UART
P0.05	RTS
P0.06	TX
P0.07	CTS
P0.08	RX

EBSPBN, EKSPBN

TAIYO YUDEN CO., LTD.

4) Size and Coordinate information

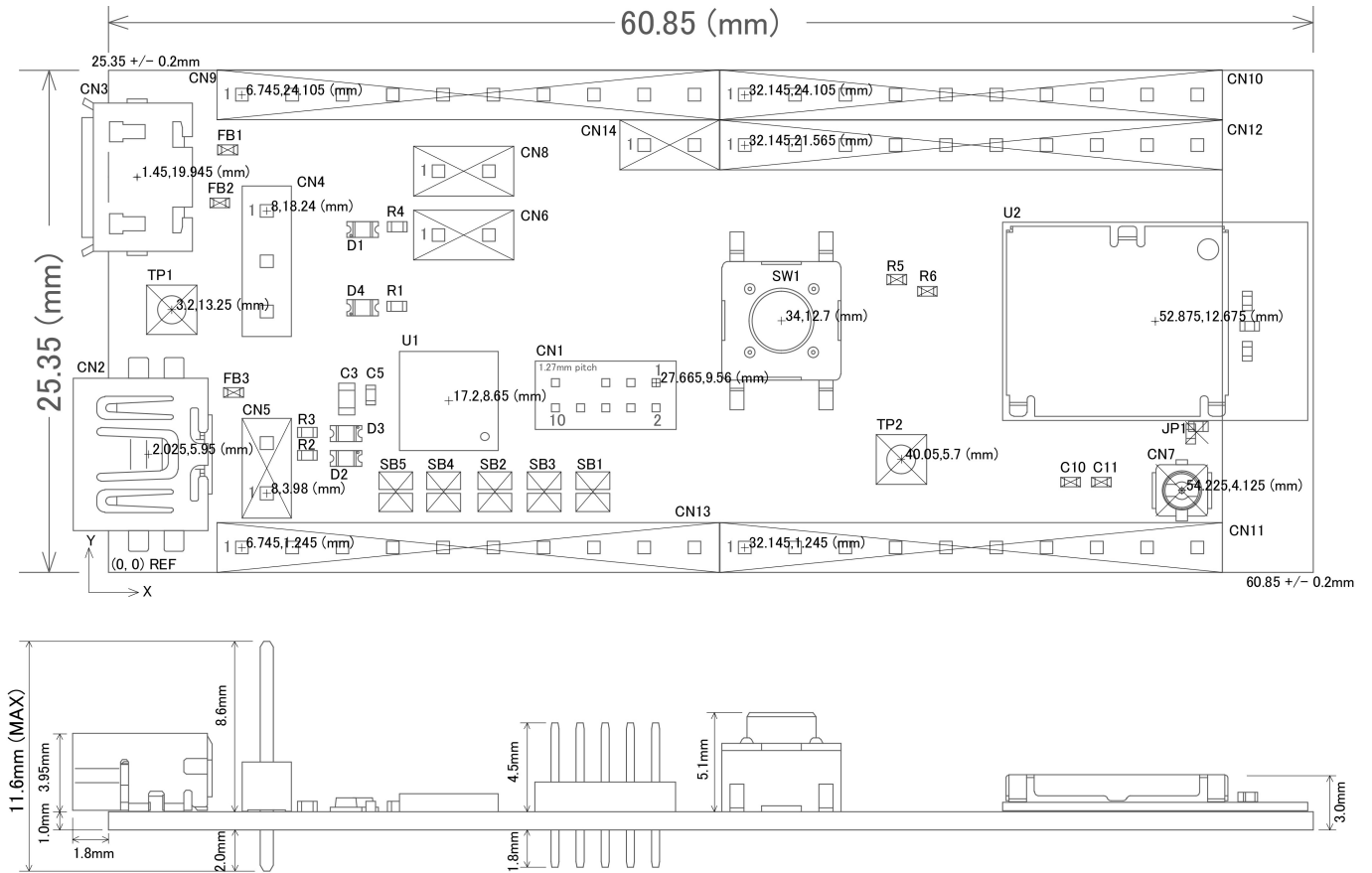

Mouser Electronics

Authorized Distributor

Click to View Pricing, Inventory, Delivery & Lifecycle Information:

[Kaga FEI:](#)

[EBSPBNZUA](#) [EKSPBNZUA](#)