

# AEM10300 Evaluation Board User Guide

## Description

The AEM10300 evaluation board is a printed circuit board (PCB) featuring all the needed components to operate the AEM10300 integrated circuit (IC).

The AEM10300 evaluation board allows users to test the e-peas IC and analyse its performances in a laboratory-like setting.

It allows easy connections to the energy harvester and the storage element. It also provides all the configuration access to set the device in any one of the modes described in the datasheet. The control and status signals are available on standard pin headers, allowing users to wire for any usage scenario and evaluate the relevant performances.

The AEM10300 evaluation board is a plug and play, intuitive and efficient tool for making the appropriate decisions (component selection, operating modes, etc) for the design of a highly efficient subsystem in your target application.

More detailed information about AEM10300 features can be found in the datasheet.

## Applications

- Asset Tracking/Monitoring
- Industrial applications
- Retail ESL/Smart sensors
- Aftermarket automotive
- Smart home/building

## Appearance

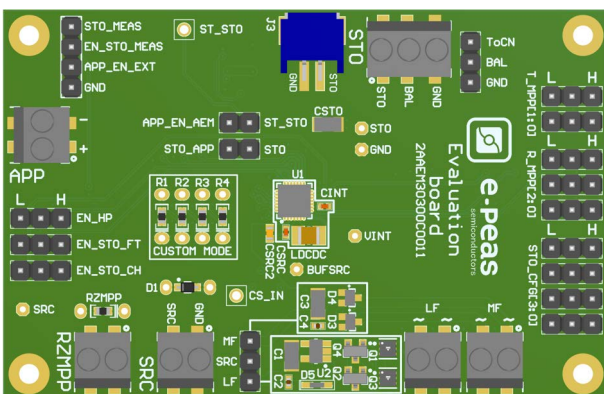

## Features

### Five two-way screw terminals

- Source of energy (DC)
- Source of energy (AC low frequency)
- Source of energy (AC medium frequency)
- ZMPP configuration
- External output supply

### One three-way screw terminal

- Energy storage element (battery or (super)capacitor)

### One 2-pin "Shrouded Header"

- Alternative connector for the storage element

### Thirteen 3-pin headers

- Maximum power point ratio (R\_MPP) configuration
- Maximum power point timing (T\_MPP) configuration
- Energy storage element threshold configuration
- Dual-cell supercapacitor configuration
- Modes configuration

### Provision for five resistors

- Custom mode configuration
- ZMPP configuration

### Configuration by 0 Ohm resistors

- Cold start input configuration

### One 1-pin header

- Access to status pin

## Device Information

Part Number	Dimensions
2AAEM10300C0010	76 mm x 50 mm

# 1. Connections Diagram

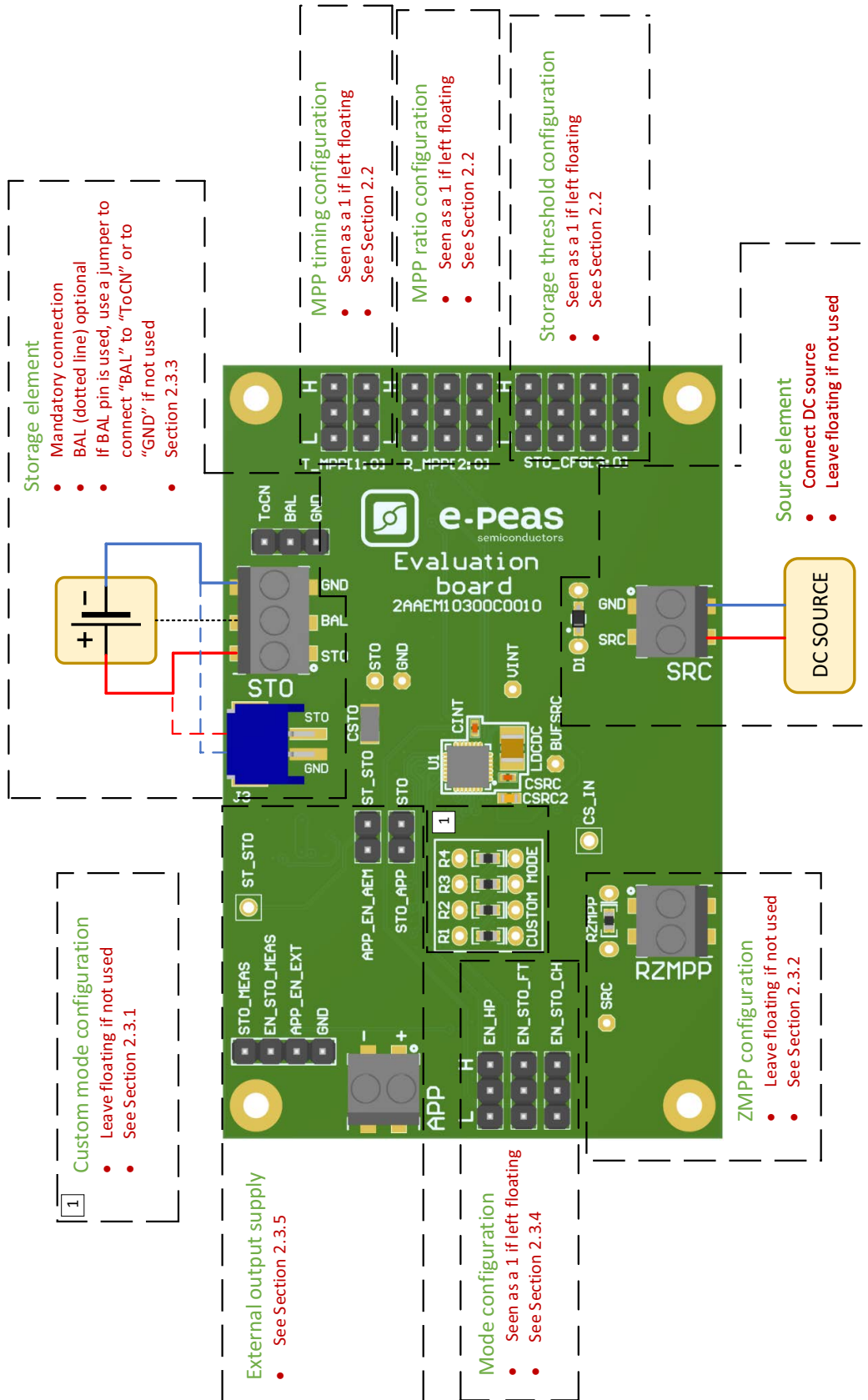

Figure 1: Connection diagram

## 1.1. Signals Description

NAME	FUNCTION	CONNECTION	
		If used	If not used
<b>Power signals</b>			
SRC	Connection to the harvested energy source.	Connect the source element.	
STO	Connection to the energy storage element.	Connect the storage element in addition to CSTO (150 $\mu$ F).	Do not remove CSTO.
BAL	Connection to balancing of the dual-cell supercapacitor.	Connect balancing and place a jumper shorting BAL and "ToCN".	Use a jumper to connect "BAL" to "GND".
APP	Connection to the application	Connect the jumper on APP_EN_AEM and a jumper on STO_APP	Remove the jumper on APP_EN_AEM and the jumper on STO_APP
<b>Debug signals</b>			
VINT	Internal voltage supply.		
BUFSRC	Connection to an external capacitor buffering the buck-boost converter input.		
<b>Configuration signals</b>			
R_MPP[2:0]	Configuration of the MPP ratio.	Connect jumper	Leave floating
T_MPP[1:0]	Configuration of the MPP timing	Connect jumper	Leave floating
STO_CFG[3:0]	Configuration of the threshold voltages for the energy storage element.	Connect jumper	Leave floating
ZMPP	Configuration of the constant impedance MPP	Use resistor RZMPP	Leave floating
<b>Control signals</b>			
EN_HP	Enabling pin for the high-power mode	Connect jumper	
EN_STO_FT	Enabling pin for the feed-through feature	Connect jumper	
EN_STO_CH	Enabling pin for the storage charging	Connect jumper	
APP_EN_AEM	Enabling pin for the application supply	Connect jumper	
APP_EN_EXT		External signal	Leave floating
EN_STO_MEAS	Enabling pin for the storage element measure	External signal	Leave floating
<b>Status signals</b>			
ST_STO	Logic output. Asserted when the storage device voltage rises above the $V_{CHRDY}$ threshold. Reset when the storage device voltage drops below $V_{OVDIS}$ threshold. High level is $V_{STO}$ .		
STO_MEAS	Voltage level on the storage element.	High level in EN_STO_MEAS (from external signal) to enable the measure.	Leave floating EN_STO_MEAS

Table 1: Pin description

## 2. General Considerations

### 2.1. Safety Information

Always connect the elements in the following order:

1. Reset the board: Short VINT, STO and SRC test points to GND.
2. Completely configure the PCB (Jumpers/resistors);
  - MPP configuration (Ratio/Timing)
  - Battery configuration
  - Balancing circuit configuration
  - Mode configuration
3. Connect the storage elements on STO.
4. Connect the source (DC or AC) to the SRC connector.

To avoid damaging the board, users are required to follow this procedure. In fact, the pins BAL cannot remain floating.

### 2.2. Basic Configurations

Configuration pins				Storage element threshold voltages			Typical use
STO_CFG[3]	STO_CFG[2]	STO_CFG[1]	STO_CFG[0]	V <sub>OVCH</sub>	V <sub>CHRDY</sub>	V <sub>OVDIS</sub>	
0	0	0	0	4.08 V	3.51 V	3.03 V	Li-ion battery
0	0	0	1	3.64 V	3.08 V	2.82 V	LiFePO4 battery
0	0	1	0	2.74 V	2.41 V	1.85 V	NiMH battery
0	0	1	1	4.65 V	1.00 V	0.20 V	Dual-cell supercapacitor
0	1	0	0	2.63 V	1.00 V	0.20V	Single-cell supercapacitor
0	1	0	1	2.99 V	1.20 V	1.00 V	Single-cell supercapacitor
0	1	1	0	2.63 V	2.30 V	1.85 V	NGK
0	1	1	1	Custom Mode			
1	0	0	0	1.49 V	1.25 V	1.1 V	Ni-Cd 1 cells
1	0	0	1	2.99 V	2.50 V	2.22 V	Ni-Cd 2 cells
1	0	1	0	4.65 V	2.00 V	1.49 V	Dual-cell supercapacitor
1	0	1	1	2.63 V	1.20 V	1.00 V	Single-cell supercapacitor
1	1	0	0	2.63 V	2.30 V	2.00 V	ITEN / Umal Murata
1	1	0	1	4.35 V	3.51 V	3.03 V	Li-Po battery
1	1	1	0	4.00 V	2.70 V	2.60 V	Tadiran TLI1020A
1	1	1	1	3.92 V	3.51 V	2.60 V	Tadiran HLC1020

Table 2: Storage Element Configuration Pins

Configuration pins			MPPT ratio
R_MPP[2]	R_MPP[1]	R_MPP[0]	$V_{MPP} / V_{OC}$
0	0	0	60%
0	0	1	65%
0	1	0	70%
0	1	1	75%
1	0	0	80%
1	0	1	85%
1	1	0	90%
1	1	1	ZMPP

Table 3: MPP Ratio Configuration Pins

Configuration pins		MPPT timing	
T_MPP[1]	T_MPP[0]	Sampling duration	Sampling period
0	0	5.19 ms	280 ms
0	1	70.8 ms	4.5 s
1	0	280 ms	17.87 s
1	1	1.12 s	71.7 s

Table 4: MPP Timing Configuration Pins

## 2.3. Advanced Configurations

A complete description of the system constraints and configurations is available in Section 8 “System configuration” of the AEM10300 datasheet.

A reminder on how to calculate the configuration resistors value is provided below. Calculation can be made with the help of the spreadsheet found on the e-peas website.

### 2.3.1. Custom Mode

In addition to the pre-defined protection levels, the custom mode allows users to define their own levels via resistors R1 to R4.

By defining  $RT = R1 + R2 + R3 + R4$  ( $1\text{ M} \leq RT \leq 100\text{ M}$ )

- $R1 = RT (1\text{ V} / V_{OVCH})$
- $R2 = RT (1\text{ V} / V_{CHR DY} - 1\text{ V} / V_{OVCH})$
- $R3 = RT (1\text{ V} / V_{OVDIS} - 1\text{ V} / V_{CHR DY})$
- $R4 = RT (1 - 1\text{ V} / V_{OVDIS})$

Make sure the protection levels satisfy the following conditions:

- $V_{CHR DY} + 0.05\text{ V} \leq V_{OVCH} \leq 4.5\text{ V}$
- $V_{OVDIS} + 0.05\text{ V} \leq V_{CHR DY} \leq V_{OVCH} - 0.05\text{ V}$
- $1\text{ V} \leq V_{OVDIS}$

If unused, leave the resistor footprints (R1 to R4) empty.

### 2.3.2. ZMPP Configuration

If this configuration is chosen (see Table 3), the AEM10300 regulates  $V_{src}$  at a voltage equals to the product of  $R_{ZMPP}$  times the current available at the source SRC.

- $10\ \Omega \leq R_{ZMPP} \leq 1\text{ M}\Omega$

If unused, leave the resistor footprint  $R_{ZMPP}$  empty.

### 2.3.3. Balancing Circuit Configuration

When using a dual-cell supercapacitor (that does not already include a balancing circuit), enable the balun circuit configuration to ensure equal voltage on both cells. To do so:

- Connect the node between the two supercapacitor cells to BAL (on STO connector)
- Use a jumper to connect “BAL” to “ToCN”

If unused, use a jumper to connect “BAL” to “GND”

### 2.3.4. Mode Configuration

#### EN\_HP

When  $EN\_HP$  is pulled up to  $V_{INT}$ , the DCDC converter is set to **HIGH POWER MODE**. This allows higher currents to be extracted from the buck-boost input (SRC) to the buck-boost output (STO or  $V_{INT}$ ).

- Use a jumper to connect  $EN\_HP$  to 1 to enable the high-power mode.
- Use a jumper to connect  $EN\_HP$  to 0 to disable the high-power mode.

#### EN\_STO\_CH

To disable battery charging, the 3-pin header is available.

- Use a jumper to connect the  $EN\_STO\_CH$  to 1 to enable the charge of the storage element
- Use a jumper to connect the  $EN\_STO\_CH$  to 0 to disable the charge of the storage element

#### EN\_STO\_FT

To disable the source to storage element feed-through, the 3-pin header is available.

- Use a jumper to connect the  $EN\_STO\_FT$  to 1 to activate the feature.
- Use a jumper to connect the  $EN\_STO\_FT$  to 0 to disable the feature.

### 2.3.5. External Output Supply

The AEM10300 is a battery charger. An external application can be supplied from the battery using the APP connector in the EVK.

To enable this feature a jumper may be placed connecting STO to  $STO\_APP$ . A switch will connect the storage element to the APP connector if one of these two signals,  $APP\_EN\_AEM$  or  $APP\_EN\_EXT$ , have a high logic level. Placing a jumper linking  $ST\_STO$  and  $APP\_EN\_AEM$  will enable the APP output when the voltage in the storage element rises above  $V_{CHR DY}$  (if the AEM comes from **RESET STATE**) and while the storage element voltages is over  $V_{OVDIS}$ . The AEM10300 goes to **RESET STATE** if there is no more energy to harvest in the SRC input, the  $ST\_STO$  signal is also reset. The  $APP\_EN\_EXT$  signal may be asserted from the application to continue using the APP output when the AEM is in **RESET STATE**.

The storage element voltage can be measured in the  $STO\_MEAS$  pin. This pin is connected to a power gated resistor bridge that can be enabled through the  $EN\_STO\_MEAS$  signal.

### 3. Functional Tests

This section presents a few simple tests that allow the user to understand the functional behaviour of the AEM10300. **To avoid damaging the board, follow the procedure found in Section 2.1 “Safety Information”.** If a test has to be restarted make sure to properly reset the system to obtain reproducible results.

The following functional tests were made using the following setup:

- Configuration:  $R\_MPP[2:0] = LLL$ ,  $T\_MPP[1:0] = LH$ ,  $STO\_CFG[3:0] = LLLL$ ,  $EN\_HP = H$ ,  $EN\_STO\_CH = H$ ,  $EN\_STO\_FT = L$
- Storage element: Capacitor (4.7 mF + CSTO)
- SRC: current source (1mA or 100uA) with voltage compliance (4V)

The user can adapt the setup to match your system as long as you respect the input and cold-start constraints (see Section 1 “Introduction” of AEM10300 datasheet).

#### 3.1. Start-up

The following example allows the user to observe the behavior of the AEM10300 in the Wake-up state.

##### Setup

- Place the probes on the nodes to be observed.
- Referring to Figure 1, follow steps 1 to 5 explained in Section 2.1 “Safety Information”.

##### Observations and measurements

- **STO**: Voltage rises as the power provided by the source is transferred to the storage element
- **ST\_STO**: Asserted when the voltage on STO rises above  $V_{CHRDY}$

#### 3.2. Shutdown

This test allows users to observe the behaviour of the AEM10300 when the system is running out of energy.

##### Setup

- Place the probes on the nodes to be observed.
- Referring to Figure 1, follow steps 1 to 5 explained in Section 2.1 “Safety Information”. Configure the board in the desired state and start the system (see Section 3.1).
- Let the system reach a steady state (i.e. voltage on **STO** between  $V_{CHRDY}$  and  $V_{OVCH}$  and **ST\_STO** asserted).
- Remove your source element and let the system discharge through quiescent current.

##### Observations and measurements

- **STO**: Voltage decreases as the system consumes the power accumulated in the storage element. The voltage reaches  $V_{OVDIS}$ .
- **ST\_STO**: De-asserted when the storage element is running out of energy ( $V_{OVDIS}$ ).

### 3.3. Cold start

The following test allows the user to observe the minimum voltage required to coldstart the AEM10300. To prevent leakage current induced by the probe the user should avoid probing any unnecessary node. Make sure to properly reset the board to observe the cold-start behaviour.

#### Setup

- Place the probes on the nodes to be observed.
- Referring Figure 1, follow steps 1 and 2 explained in Section 2.1. Configure the board in the desired state. Do not plug any storage element in addition to CSTO.
- **SRC**: Connect your source element.

#### Observations and measurements

- **SRC**: Equal to the cold-start voltage during the coldstart phase. Regulated at the selected MPPT percentage of Voc when cold start is over. Be careful that the cold-start phase time will shorten with the input power. Limit it to ease the observation.
- **STO**: Starts to charge the storage element when the cold-start phase is over

### 3.4. Dual-cell supercapacitor balancing circuit

This test allows users to observe the balancing circuit behaviour that maintains the voltage on BAL equilibrated.

#### Setup

- Following steps 1 and 2 explained in Section 2.1 and referring to Figure 1, configure the board in the desired state. Plug the jumper linking "BAL" to "ToCN".
- **STO**: Plug capacitor C1 between the positive (+) and the BAL pins and a capacitor C2 between BAL and the negative (-) pins.  
Select  $C1 \neq C2$  such that:

- $C1 \& C2 > 1\text{mF}$
- $(C2 * V_{\text{CHRDY}})/C1 \geq 0.9\text{V}$
- **SRC**: Plug your source element to start the power flow to the system

#### Observations and measurements

- **BAL**: Equal to half the voltage on **STO**

**Do not leave BAL floating, you risk damaging the AEM.**

### 3.5. Source to Storage Element Feed-Through

This example allows users to observe the feed-through feature.

#### Setup

- Place the probes on the nodes to be observed.
- Referring to Figure 1, follow steps 1 to 5 explained in Section 2.1 "Safety Information". Configure the board in the desired state and start the system (see Section 3.1).
- Let the system reach a steady state (i.e. voltage on **STO** between  $V_{\text{CHRDY}}$  and  $V_{\text{OVCH}}$  and **ST\_STO** asserted).
- **EN\_STO\_FT**: Connect to H
- **SRC**: current source (1mA or 100uA) with voltage compliance (5V)
- Put a capacitor (>1mF) on **SRC** and **STO** to avoid perturbation due to the SMU behavior.

#### Observations and measurements

- **STO**: The current from the source is transferred directly to the storage element



## 4. Schematics

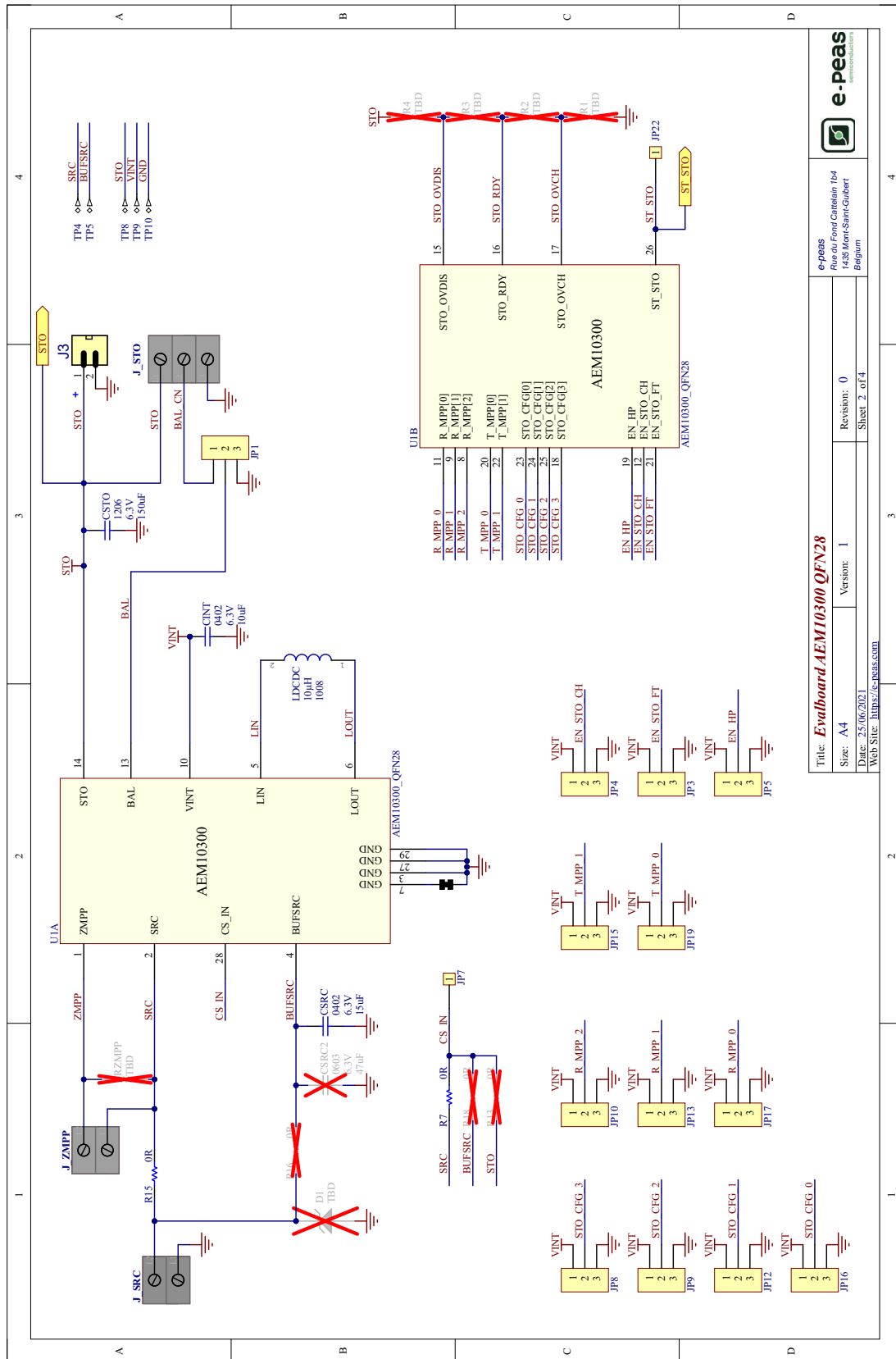
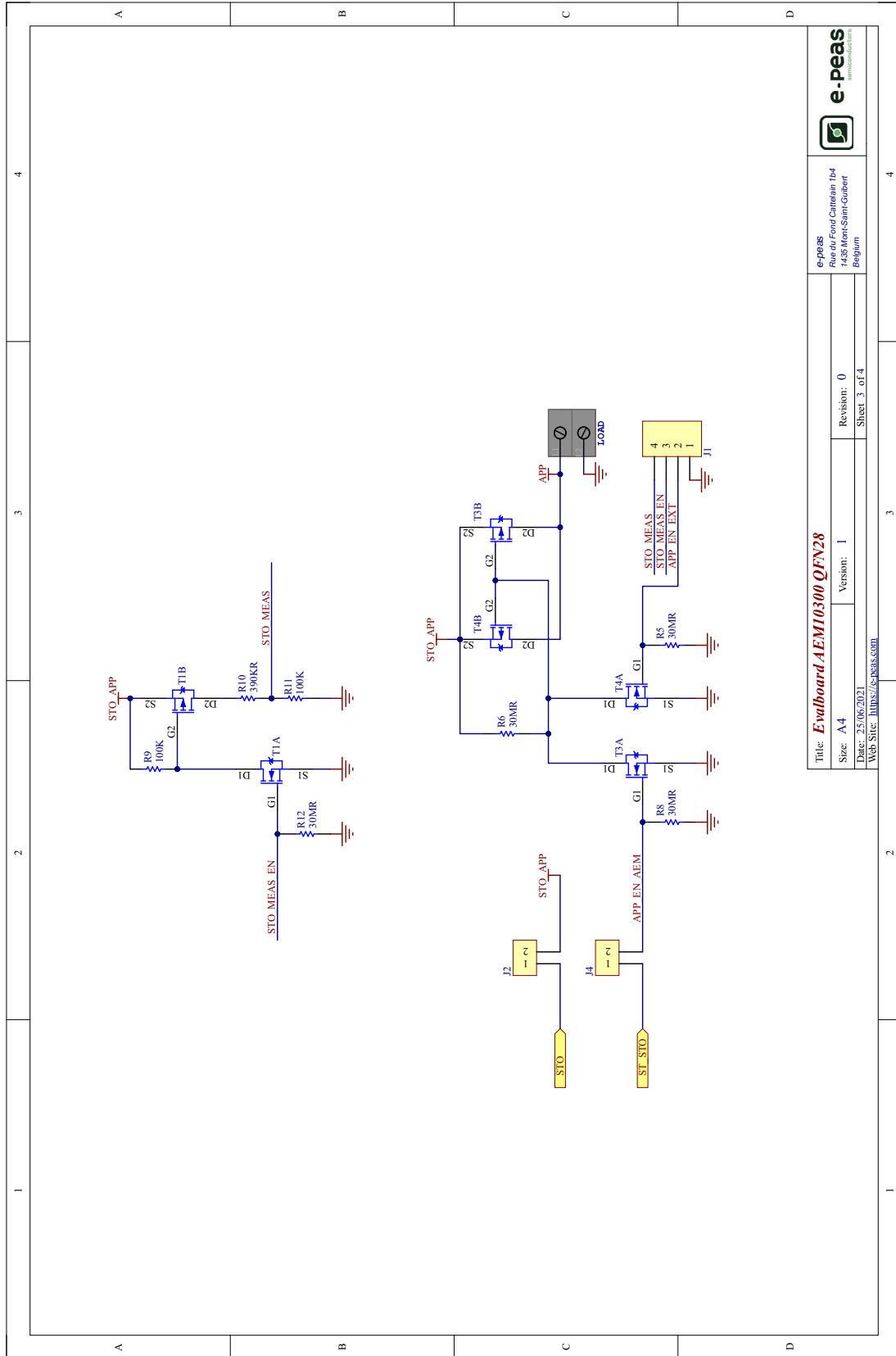

Figure 2: Schematic part 1



Title: **EvaluationBoard AEM10300 QFN28**  
 Size: A4  
 Date: 25/06/2021  
 Web Site: <https://e-peas.com>

e-peas  
Rue du Fond Calvaire 104  
B-1303 Melle/St-Amand-Guibert  
Belgium

Revision: 0  
 Sheet 3 of 4

Figure 3: Schematic part 2

# Mouser Electronics

Authorized Distributor

Click to View Pricing, Inventory, Delivery & Lifecycle Information:

[e-peas:](#)

[EVK10300](#)