

Mini Evaluation Board : AEM10941



e-peas
semiconductors

Please follow the next steps when using the AEM10941 mini evaluation board



- Step 1 :** MPP configuration (DS page 12)
- Step 2 :** System configuration (DS page 11)
- Step 3 :** LDO outputs configuration (DS page 9)
- Step 4 :** Cold-start configuration (DS page 12)
- Step 5 :** Balun for dual-cells supercapacitor (DS page 10)
- Step 6 :** Primary battery configuration (DS page 12)
- Step 7 :** Connect the storage element
- Step 8 :** Connect the primary battery
- Step 9 :** Connect the loads
- Step 10 :** Connect the source
- Step 11 :** Status

For more information : support@e-peas.com

Mini Evaluation Board : AEM10941



e-peas
semiconductors

1.

SELMPP1-0	MPPT Ratio (%)
0-0	70
0-1	75
1-0	85
1-1	90

2.

CFG2-1-0	Storage element type
H-H-H	Li-ion battery
H-H-L	Solid state Battery
H-L-H	Li-ion / NiMH battery
H-L-L	Single cell supercapacitor
L-H-H	Dual cell supercapacitor
L-H-L	Dual cell supercapacitor
L-L-H	LifePo4
L-L-L	Custom mode

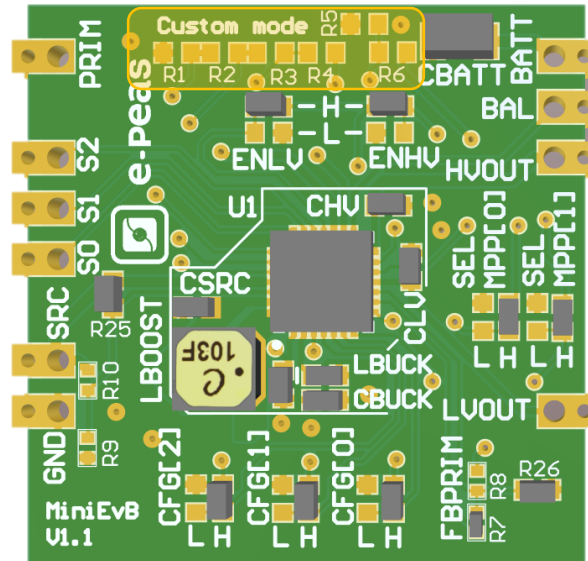

1. MPP configuration
(DS page 12)

2. System configuration (DS page 11)

Please see DS page 11 « Custom mode »
and use the **R1 – R6** resistors

Mini Evaluation Board : AEM10941



e-peas
semiconductors

3.

ENLV	ENHV	LVOUT	HVOUT
1	1	Enabled	Enabled
1	0	Enabled	Disabled
0	1	Disabled	Enabled
0	0	Disabled	Disabled

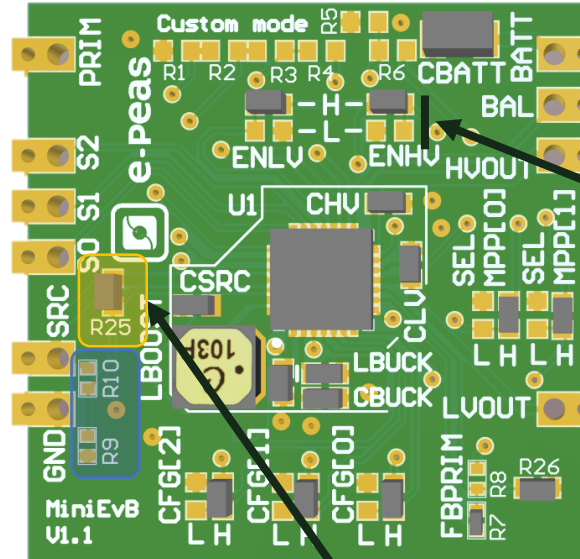

3. LDO outputs configuration
(DS page 9)

4.

Solder resistor « 0R R25 » if not used else :

4. Cold-start configuration (DS page 12)

$$100 \text{ k}\Omega \leq RC = R9 + R10 \leq 10 \text{ M}\Omega$$

CS = coldstart voltage (> 380mV)

$$R9 = \frac{0.38}{CS} * RC$$

$$R10 = RC - R9$$

For more information : support@e-peas.com

Mini Evaluation Board : AEM10941



e-peas
semiconductors

5.

If dual-cell supercapacitor :
BAL connected to the node
between the supercapacitors

BAL = ToCN

If not :

BAL = GND

Do not leave floating PRIM or BAL

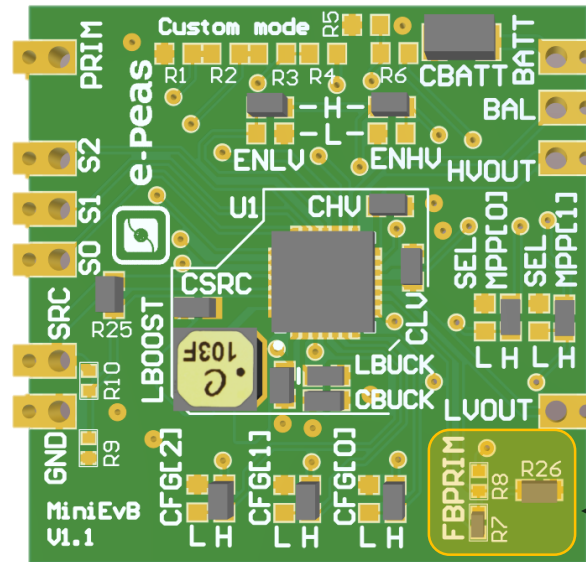

5. Balun for dual-cells
supercapacitor
(DS page 10)

6.

Solder resistor « 0R R26 » if no primary battery
else

$$100 \text{ k}\Omega \leq R_P = R_7 + R_8 \leq 500 \text{ k}\Omega$$

V_{PRIM_MIN} = minimum voltage on PRIM

$$R_7 = \left(\frac{V_{PRIM_MIN}}{4} * R_P \right) / 2.2 \text{ V}$$

$$R_8 = R_P - R_7$$

6. Primary battery configuration
(DS page 12)

For more information : support@e-peas.com

Mini Evaluation Board : AEM10941

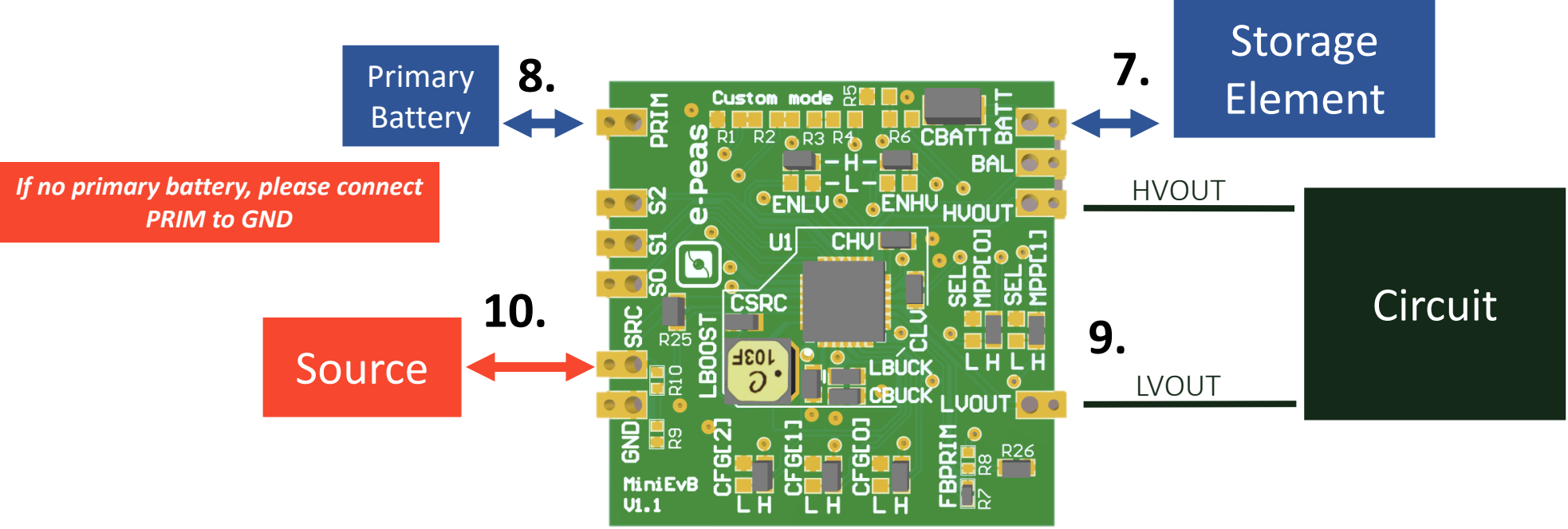

For more information : support@e-peas.com

Visit us on

www.e-peas.com

Or contact us at

support@e-peas.com

sales@e-peas.com

Mouser Electronics

Authorized Distributor

Click to View Pricing, Inventory, Delivery & Lifecycle Information:

[e-peas:](#)

[EVK10941M](#)