



ES9016K2M Ultra 32-bit Stereo Low Power Audio DAC Datasheet

The **ES9016K2M SABRE³²® Ultra DAC** is a high-performance 32-bit, 2-channel audio D/A converter targeted for portable high-fidelity audio power sensitive applications such as digital music players, consumer applications such as Blu-ray players, audio pre-amplifiers and A/V receivers, as well as professional applications such as recording systems, mixer consoles and digital audio workstations.

Using the critically acclaimed ESS patented 32-bit HyperStream® DAC architecture and Time Domain Jitter Eliminator, the **ES9016K2M SABRE³²® Ultra DAC** delivers a DNR of up to 122dB and THD+N of -110dB, a performance level that will satisfy the most demanding audio enthusiasts.

The **ES9016K2M SABRE³²® Ultra DAC**'s 32-bit HyperStream® architecture can handle up to 32-bit, 384kHz PCM data via I²S, DSD-11.2MHz data as well as mono mode for highest performance applications. Both synchronous and ASRC (asynchronous sample rate conversion) modes are supported.

The **ES9016K2M SABRE® Ultra DAC** is powered by a +1.8V to +3.3V supply for both the digital and analog sections, with internal regulators generating the core supply. The DAC comes in a 28-QFN package, supports 1.8V logic levels and consumes less than 40mW in normal operating mode (< 1mW in standby mode)

The **SABRE® Ultra DAC** sets a new standard for high quality audio performance, **SABRE SOUND®**, in a cost effective, easy-to-use form factor for today's most demanding digital audio applications.

FEATURE	DESCRIPTION
Patented 32-bit HyperStream® DAC ○ +122dB DNR ○ -110dB THD+N	○ 32-bit audio DAC powered by Sabre ³² ® DAC architecture with unmatched dynamic range and ultra low distortion ○ Supports both synchronous and ASRC (asynchronous sample rate converter) modes
Patented Time Domain Jitter Eliminator	○ Unmatched audio clarity free from input clock jitter
64-bit accumulator and 32-bit processing	○ Distortion free signal processing
Integrated DSP Functions	○ Click-free soft mute and volume control ○ Programmable Zero detect ○ De-emphasis for 32kHz, 44.1kHz, and 48kHz sampling
Customizable output configuration	○ Mono or stereo output in current or voltage mode based on performance criterion
I ² C control	○ Allows software control of DAC features
28-QFN (5mm x 5mm) package	○ Minimizes PCB footprint
< 40mW operating, < 1mW standby power	○ Maximizes battery life
1.8 to 3.3V analog & digital power supplies	○ Reduces power and simplifies power supply design
1.8V digital logic supported	○ Connects to Application Processor without level shifter
Versatile digital input	○ Supports SPDIF, PCM (I ² S, LJ 16-32-bit) or DSD input
Customizable filter characteristics	○ User programmable filter allowing custom roll-off response ○ Bypassable oversampling filter

APPLICATIONS

- Mobile phones / Tablets / Digital music players / Portable multimedia players
- Blu-ray / SACD / DVD-Audio player
- Audio preamplifier and A/V receiver
- Professional audio recording systems / Mixing consoles / Digital audio workstation

New product version is available in ES9020Q



ES9016K2M Datasheet

FUNCTIONAL BLOCK DIAGRAM

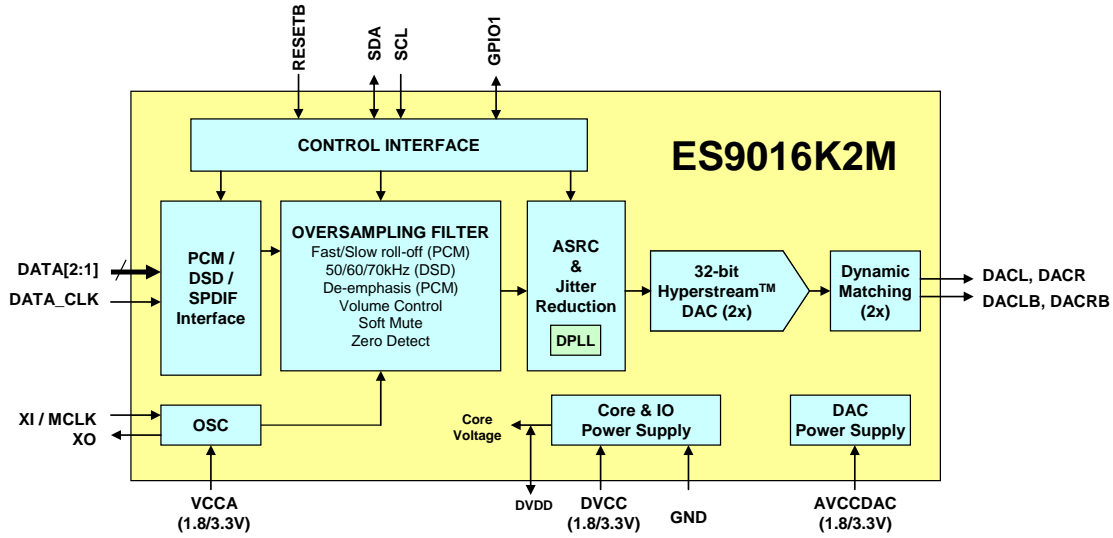

TYPICAL APPLICATION DIAGRAM

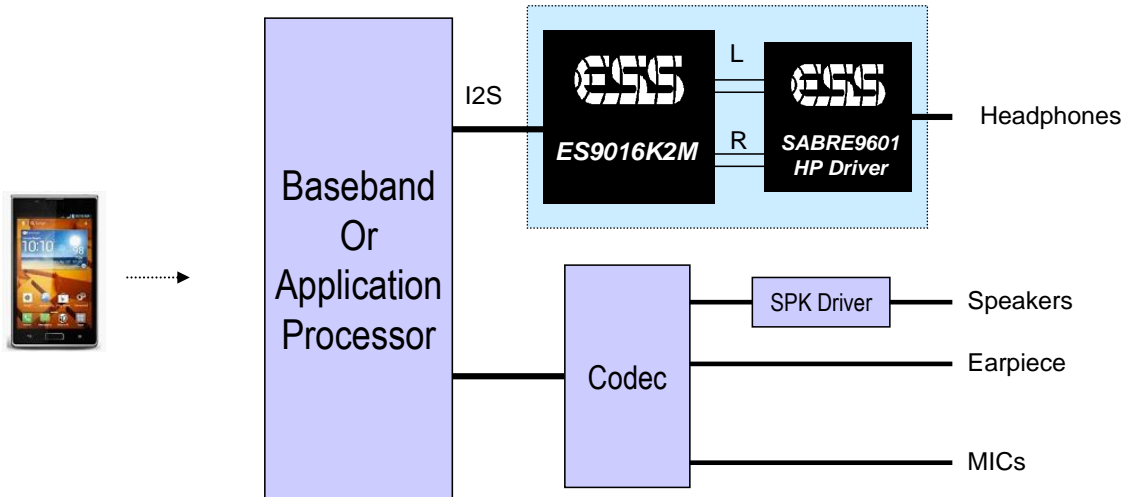

New product version is available in ES9020Q

ES9016K2M Datasheet



PIN LAYOUT

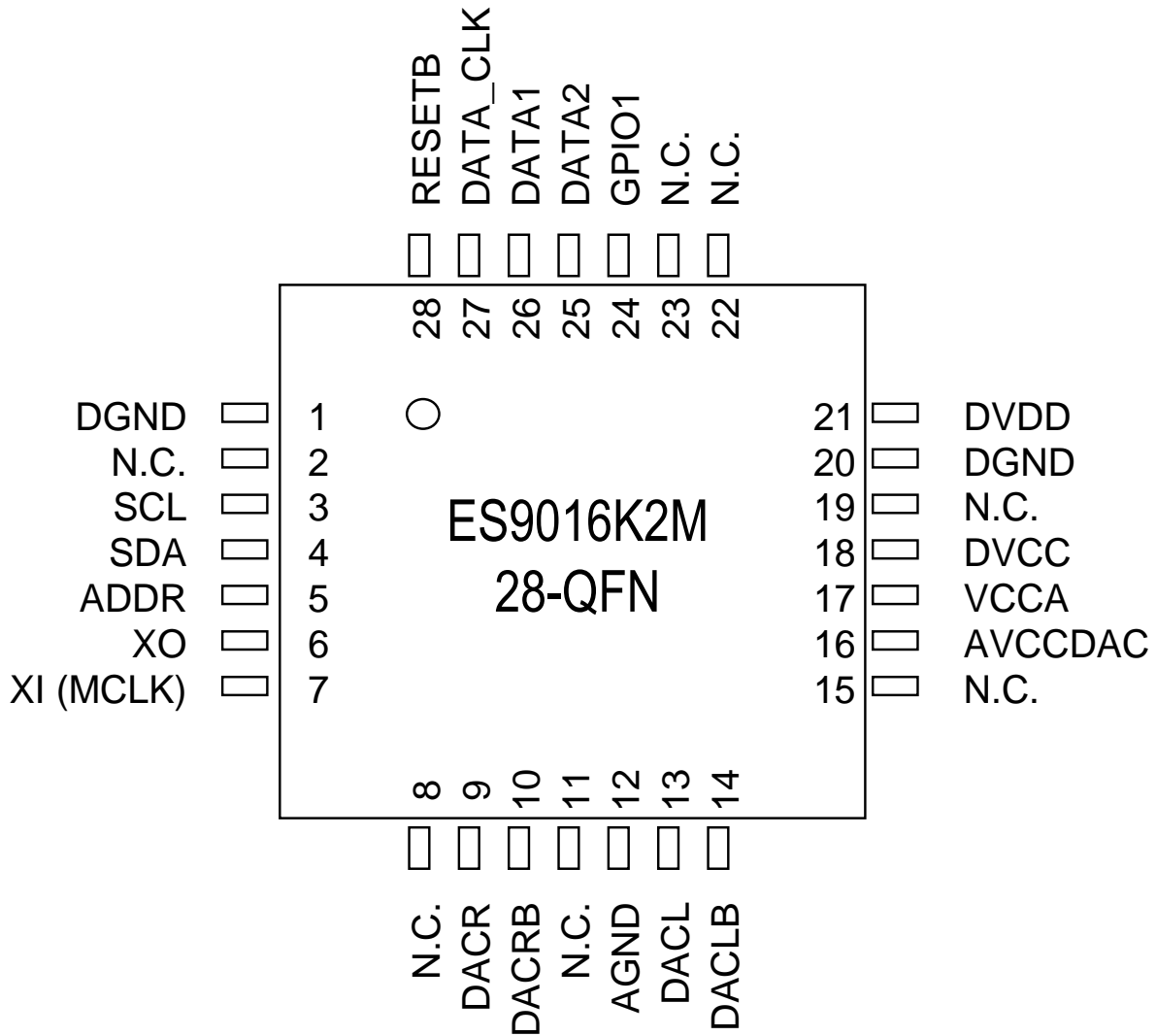

New product version is available in ES9020Q



ES9016K2M Datasheet

PIN DESCRIPTIONS

Pin	Name	Pin Type	Reset State	Pin Description
1	DGND	Ground	Ground	Digital Ground
2	N.C.	-	-	No internal connection. Pin may be grounded if desired.
3	SCL	I	Tri-stated	I ² C Serial Clock Input
4	SDA	I/O	Tri-stated	I ² C Serial Data Input/Output
5	ADDR	I	Tri-stated	I ² C Address Select
6	XO	AO	Floating	XTAL Out
7	XI (MCLK)	AI	Floating	XTAL / MCLK In
8	N.C.	-	-	No internal connection. Pin may be grounded if desired.
9	DACR	AO	Driven to ground	Differential Positive Analog Output Right
10	DACRB	AO	Driven to ground	Differential Negative Analog Output Right
11	N.C.	-	-	No internal connection. Pin may be grounded if desired.
12	AGND	Ground	Ground	Analog Ground
13	DACL	AO	Driven to ground	Differential Positive Analog Output Left
14	DACLB	AO	Driven to ground	Differential Negative Analog Output Left
15	N.C.	-	-	No internal connection. Pin may be grounded if desired.
16	AVCCDAC	Power	Power	Analog AVCC for DAC
17	VCCA	Power	Power	Analog +1.8V or +3.3V for OSC
18	DVCC	Power	Power	Digital +1.8V to +3.3V
19	N.C.	-	-	No internal connection. Pin may be grounded if desired.
20	DGND	Ground	Ground	Digital Ground
21	DVDD	Power	Power	Digital Core Voltage, nominally +1.2V, is supplied by a regulator from DVCC. DVDD must be decoupled with a minimum 4.7 μ F capacitor to DGND for stable operation. DVDD needs to be externally supplied for high XI / MCLK frequency. Please refer to the section about the DVDD supply on page 7 for additional information.
22	N.C.	-	-	No internal connection. Pin may be grounded if desired.
23	N.C.	-	-	No internal connection. Pin may be grounded if desired.
24	GPIO1	I/O	Tri-stated	GPIO 1
25	DATA2	I	Tri-stated	DSD Data2 (R) or PCM Data CH1/CH2 or SPDIF Input 2
26	DATA1	I/O	Tri-stated	Master mode off: Input for DSD Data1 (L) or PCM Frame Clock or SPDIF Input 3 Master mode on: Output for PCM Frame Clock
27	DATA_CLK	I/O	Tri-stated	Master mode off: Input for PCM Bit Clock or DSD Bit Clock or SPDIF Input 1 Master mode on: Output for PCM Bit Clock
28	RESETB	I	Tri-stated	Master Reset / Power Down (active low)
Exposed Pad	DGND	Ground	Ground	Digital Ground. Connect the Exposed Pad to DGND

Notes:

- There are 7 N.C. (No Connect) pins. If desired, these pins can be connected to ground on the PCB to strengthen the otherwise isolated pin pads.
- The exposed pad must be connected to digital ground.

New product version is available in ES9020Q

ES9016K2M Datasheet



FUNCTIONAL DESCRIPTION

NOTATIONS for Sampling Rates

Mode	fs (target sample rate)	FSR (raw sample rate)
DSD	DATA_CLK / 64	DSD data rate
Serial (PCM) Normal Mode	Frame Clock Rate	Frame Clock Rate
Serial (PCM) OSF Bypass Mode	Frame Clock Rate / 8	Frame Clock Rate
SPDIF	SPDIF Sampling Rate	SPDIF Sampling Rate

PCM, SPDIF and DSD Pin Connections

PCM Audio Format

Notes:

XI clock (MCLK) must be > 192 x FSR when using PCM input (normal mode), or 128 x FSR (synchronous MCLK).
XI clock (MCLK) must be > 24 x FSR when using PCM input (OSF bypass mode).

Pin Name	Description
DATA1	Frame clock
DATA2	2-channel PCM serial data
DATA_CLK	Bit clock for PCM audio format

Master Mode (32-bit data only)

When Register #1 'input_select' is set to 2'd0 (I²S) and 'i2s_length' is set to 2'd2 (32-bit), the DAC can become a master for Bit Clock and Frame Clock by setting Register #9 'master clock enable' to 1'b1. The Bit Clock frequency can be configured to MCLK / 4, MCLK / 8 or MCLK / 16 by setting Register #9 'clock divider select' to 2'b00, 2'b01 or 2'b10. GPIO 1 can be configured to output MCLK by setting Register #8 gpio1_cfg to 4'd3.

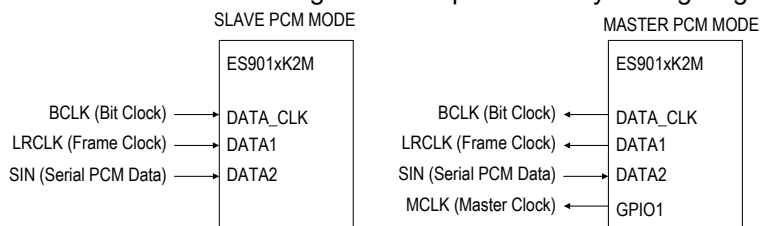

SPDIF Audio Formant

Note: XI clock (MCLK) must be > 386 x FSR when using SPDIF input.

Up to four SPDIF inputs can be connected to the 4-to-1 mux, selectable via register "spdif_sel". SPDIF can also be sourced from a GPIO pin configured as input.

Pin Name	Description
GPIO1	SPDIF input 4
DATA1	SPDIF input 3
DATA2	SPDIF input 2
DATA_CLK	SPDIF input 1

DSD Audio Format

Note: XI clock (MCLK) must be > 3 x FSR when using DSD input.

Pin Name	Description
DATA[1:2]	2-channel DSD data input
DATA_CLK	Bit clock for DSD data input



New product version is available in ES9020Q

ES9016K2M Datasheet

FEATURE DESCRIPTION

Soft Mute

When Mute is asserted the output signal will ramp to the $-\infty$ level. When Mute is reset the attenuation level will ramp back up to the previous level set by the volume control register. Asserting Mute will not change the value of the volume control register. The ramp rate is $0.0078125 \times fs / 2^{(vol_rate-5)}$ dB/s.

Automute

During an automute condition the ramping of the volume of each DAC to $-\infty$ can now be programmatically enabled or disabled.

- In PCM serial mode, "AUTOMUTE" will become active once the audio data is continuously below the threshold set by <Register Automute_lev>, for a length of time defined by $2096896 / (<Register\#4> \times 64 \times fs)$ seconds.
- In SPDIF mode, "AUTOMUTE" will become active once the audio data is continuously below the threshold set by <Register Automute_lev>, for a length of time defined by $2096896 / (<Register\#4> \times (64 \times fs))$ seconds.
- In the DSD Mode, "AUTOMUTE" will become active when any 8 consecutive values in the DSD stream have as many 1's and 0's for a length of time defined by $2096896 / (<Register\ Automute_time> \times DATA_CLK)$ seconds. The following table summarizes the conditions.

Mode	Detection Condition	Time
PCM	Data is continuously lower than <Register Automute_lev >	$2096896 / (<Register\ Automute_time > \times 64 \times fs)$
SPDIF	Data is continuously lower than <Register Automute_lev >	$2096896 / (<Register\ Automute_time > \times (64 \times fs))$
DSD	Equal number of 1s and 0s in every 8 bits of data	$2096896 / (<Register\ Automute_time > \times DATA_CLK)$

Volume Control

Each output channel has its own attenuation circuit. The attenuation for each channel is controlled independently. Each channel can be attenuated from 0dB to -127 dB in 0.5dB steps.

Each 0.5dB step transition takes up to 64 intermediate levels, depending on the vol_rate register setting. The result being that the level changes are done using small enough steps so that no switching noise occurs during the transition of the volume control. When a new volume level is set, the attenuation circuit will ramp softly to the new level.

Master Trim

The master trim sets the 0dB reference level for the volume control of each DAC. The master trim is programmable via registers 17-20 and is a 32bit signed number. Therefore it should never exceed $32'h7FFFFFFF$ (as this is full-scale signed).

All Mono Mode

An all mono mode where all DACs are driven from the same source is supported. This can be useful for high-end audio applications. The source data for all DACs can be programmatically configured to be either CH1 or CH2.

De-emphasis

The de-emphasis feature is included for audio data that has utilized the 50/15 μ s pre-emphasis for noise reduction. There are three de-emphasis filters, one for 32kHz, one for 44.1kHz, and one for 48kHz.

SPDIF Data Select

An SPDIF source multiplexer allows for up to four SPDIF sources to be connected to the data pins. An internal programmable register (spdif_sel) is used to select the appropriate data or GPIO pin to decode. SPDIF can also be sourced from GPIO pin configured as input.

New product version is available in ES9020Q

ES9016K2M Datasheet



System Clock (XI / MCLK)

A system clock is required for proper operation of the digital filters and modulation circuitry. See p.28, Note 2 for the maximum MCLK frequencies supported. The minimum system clock frequency must also satisfy:

Data Type	Minimum MCLK Frequency	Note
DSD Data	$MCLK > 3 \times FSR$, $FSR = 2.8224MHz$ (x 1, 2 or 4)	The maximum FSR frequency is further limited by the maximum MCLK frequencies supported as shown p.28, Note 2.
Serial Normal Mode	$MCLK > 192 \times FSR$, $FSR \leq 384kHz$ or $MCLK = 128 \times FSR$ (synchronous MCLK) with $FSR \leq 384kHz$	
Serial OSF Bypass Mode	$MCLK > 24 \times FSR$, $FSR \leq 1.536MHz$	
SPDIF Data	$MCLK > 386 \times FSR$, $FSR \leq 200kHz$	

Data Clock

DATA_CLOCK must be $(2 \times i2s_length) \times FSR$ for SERIAL, and FSR for DSD modes. For SPDIF mode, this pin is used for SPDIF input. This pin should be pulled low if not used.

Built-in Digital Filters

Three digital filters (fast roll-off, slow roll-off and minimum phase filters) are included for PCM data. See 'PCM Filter Characteristics' for more information.

Standby Mode

For lowest power consumption, the following sequence should be performed to enter stand-by mode:

- Set the soft start bit in register 14 to 1'b0 to ramp the DAC outputs (DACL, DACLB, DACR, DACRB) to ground.
- RESETB pin should be brought to low digital level to:
 - Shut off the DACs, Oscillator and internal regulator.
 - Force digital I/O pins (DATA_CLK, DATA1, GPIO1, SDA) into tri-state mode
 - Reset all registers to default states
- If XI/MCLK is supplied externally, it should be stopped at logic low level
- If DVDD is supplied by an external regulator, it should be shutdown during standby

To resume from standby mode, bring RESETB to high digital level and reinitialize all registers.

DVDD Supply

The ES9016K2M is equipped with an internal, regulated DVDD supply powered from DVCC. The internal DVDD regulator must be decoupled to DGND with a 4.7 μ F minimum capacitor for stable operation. Recommended capacitor for decoupling DVDD is a 4.7 μ F \pm 20%, X5R 6.3V 0402, e.g. TDK part number C1005X5R0J475M050BC or similar.

- The internal DVDD should be used except under the following conditions:
 1. PCM (SPDIF, I²S with OSF Bypass off or on): $MCLK > 50MHz$ or $FSR > 192kHz$
 2. DSD: $MCLK > 50MHz$ or $FSR > 11.2MHz$
- Internal DVDD may be used up to the maximum supported MCLK frequencies specified on p.28, Note 2. An External DVDD (+1.3V) supply must be used above those frequencies. The external supply voltage must be greater than the internal supply of +1.2V so the internal supply is disabled.



New product version is available in ES9020Q

ES9016K2M Datasheet

Programmable FIR filter

A two stage interpolating FIR design is used. The interpolating FIR filter is generated using MATLAB, and can then be downloaded using a custom C code.

Example Source Code for Loading a Filter

```
// only accept 128 or 16 coefficients
// Note: The coefficients must be quantized to 24 bits for this method!
// Note: Stage 1 consists of 128 values (0-127 being the coefficients)
// Note: Stage 2 consists of 16 values (0-13 being the coefficients, 14-15 are zeros)
// Note: Stage 2 is symmetric about coefficient 13. See the example filters for more information.
byte reg26 = (byte)(coeffs.Count == 128 ? 0 : 128);
for (int i = 0; i < coeffs.Count; i++)
{
    // stage 1 contains 128 coefficients, while stage 2 contains 16 coefficients
    registers.WriteRegister(26, (byte)(reg26 + i));

    // write the coefficient data
    registers.WriteRegister(27, (byte)(coeffs[i] & 0xff));
    registers.WriteRegister(28, (byte)((coeffs[i] >> 8) & 0xff));
    registers.WriteRegister(29, (byte)((coeffs[i] >> 16) & 0xff));

    registers.WriteRegister(30, 0x02); // set the write enable bit
}
// disable the write enable bit when we're done
registers.WriteRegister(30, (byte)(setEvenBit ? 0x04 : 0x00));
```

OSF Bypass

The oversampling FIR filter can be bypassed, sourcing data directly into the IIR filter. ESS recommends using 8 x FSR as the input. For example, an external signal at 44.1kHz can be oversampled externally to 8 x 44.1kHz = 352.8kHz and then applied to the serial decoder in either I²S or LJ format. The maximum sample rate that can be applied is 1.536MHz (8 x 192kHz).

ES9016K2M Datasheet



Audio Interface Formats

Several interface formats are provided so that direct connection to common audio processors is possible. The available formats and their accompanying diagrams are listed in the following table. The audio interface format can be set by programming the registers.

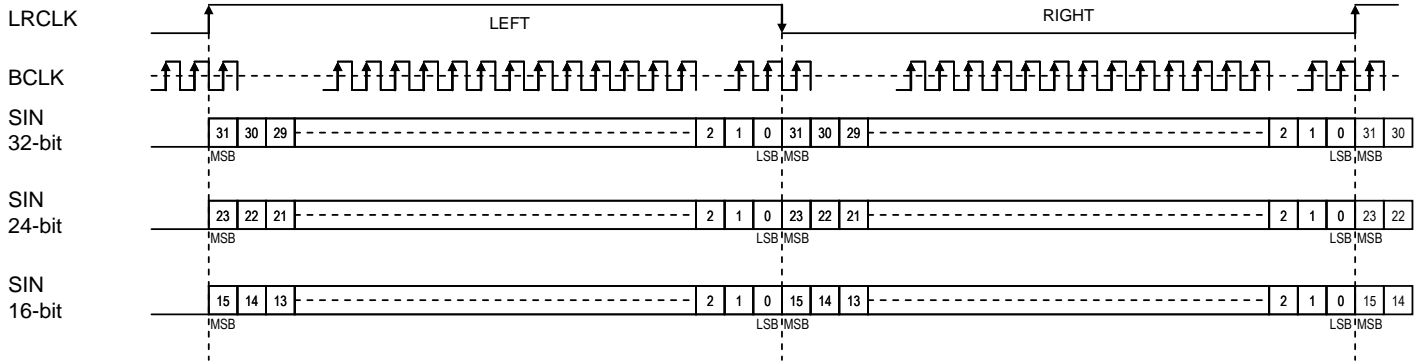

LEFT JUSTIFIED FORMAT

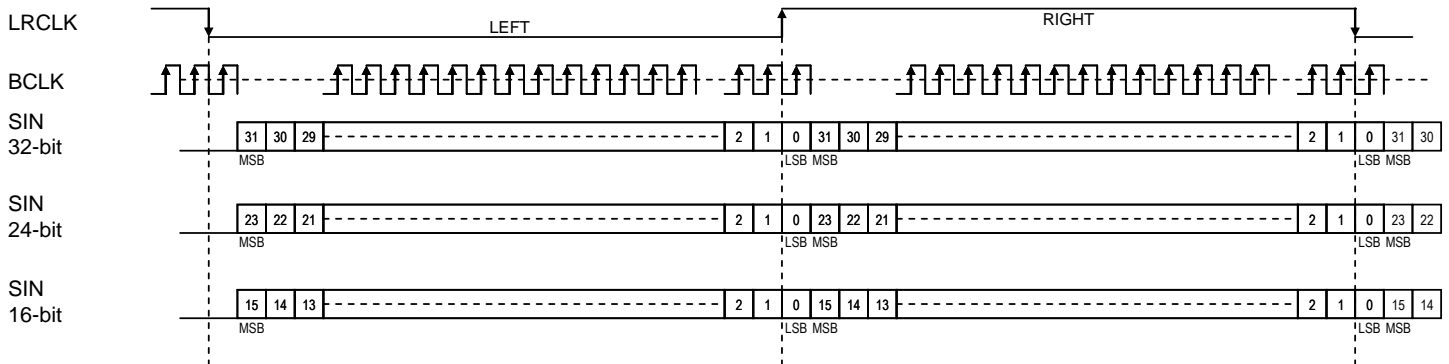

I2S FORMAT

Note: for Left-Justified and I²S formats, the following number of BCLKs is present per LRCLK frame (left plus right channels):

- 16-bit mode: 32 BCLKs
- 24-bit mode: 48 BCLKs
- 32-bit mode: 64 BCLKs

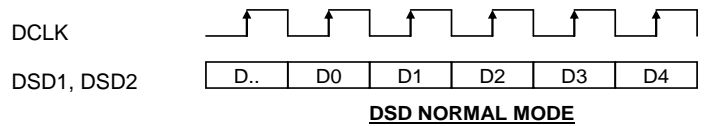

DSD NORMAL MODE

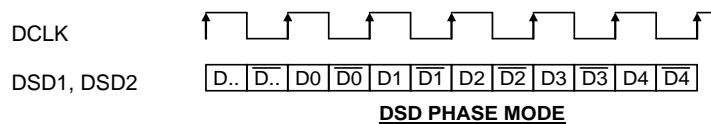

DSD PHASE MODE

New product version is available in ES9020Q



ES9016K2M Datasheet

SERIAL CONTROL INTERFACE

The registers inside the chip are programmed via an I²C interface. The diagram below shows the timing for this interface. The chip address can be set to 2 different settings via the “ADDR” pin. The table below summarizes this.

ADDR	CHIP ADDRESS
0	0x90
1	0x92

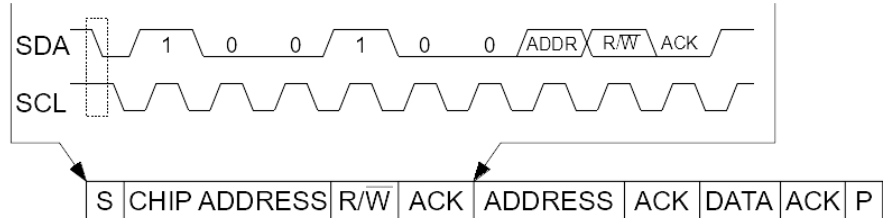

Notes:

1. The “ADDR” pin is used to create the CHIP ADDRESS. (0x90, 0x92)
2. The first byte after the chip address is the “ADDRESS” this is the register address.
3. The second byte after the CHIP ADDRESS is the “DATA” this is the data to be programmed into the register at the previous “ADDRESS”.

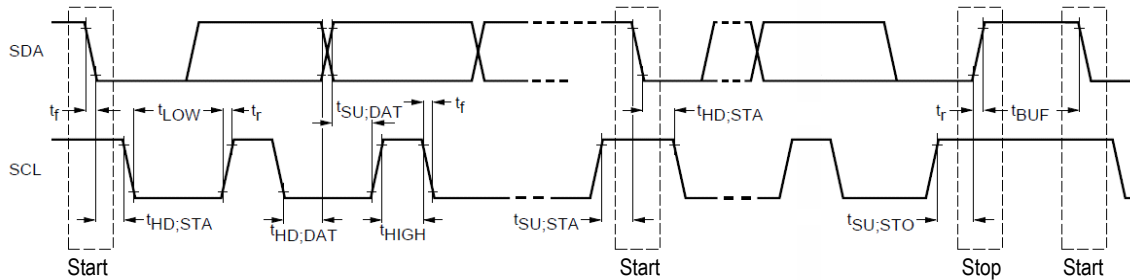

Parameter	Symbol	Standard-Mode		Fast-Mode		Unit
		MIN	MAX	MIN	MAX	
SCL Clock Frequency	f_{SCL}	0	100	0	400	kHz
START condition hold time	$t_{HD,STA}$	4.0	-	0.6	-	μ S
LOW period of SCL	t_{LOW}	4.7	-	1.3	-	μ S
HIGH period of SCL	t_{HIGH}	4.0	-	0.6	-	μ S
START condition setup time (repeat)	$t_{SU,STA}$	4.7	-	0.6	-	μ S
SDA hold time from SCL falling	$t_{HD,DAT}$	0.3	-	0.3	-	μ S
SDA setup time from SCL rising	$t_{SU,DAT}$	250	-	100	-	ns
Rise time of SDA and SCL	t_r	-	1000	-	300	ns
Fall time of SDA and SCL	t_f	-	300	-	300	ns
STOP condition setup time	$t_{SU,STO}$	4	-	0.6	-	μ S
Bus free-time between transmissions	t_{BUF}	4.7	-	1.3	-	μ S
Capacitive load for each bus line	C_b	-	400	-	400	pF

New product version is available in ES9020Q

ES9016K2M Datasheet



REGISTER MAP

Address (Dec/Hex)	Register	D7 (MSB)	D6	D5	D4	D3	D2	D1	D0 (LSB)	
Read/Write										
0 / 0x00	SYSTEM SETTINGS	OSC_DRV				RESERVED			SOFT_RESET	
1 / 0x01	INPUT CONFIGURATION	I2S_LENGTH		I2S_MODE		AUTO_INPUT_SELECT		INPUT_SELECT		
2 / 0x02	RESERVED	RESERVED								
3 / 0x03	RESERVED	RESERVED								
4 / 0x04	AUTOMUTE_TIME	AUTOMUTE_TIME								
5 / 0x05	AUTOMUTE_LEVEL	AUTOMUTE_LOOPBACK	AUTOMUTE_LEVEL							
6 / 0x06	SOFT VOLUME CONTROL 3 & DE-EMPHASIS	SPDIF_AUTO_DEEMPH	DEEMPH_BYPASS	DEEMPH_SEL		RESERVED	VOL_RATE			
7 / 0x07	GENERAL SETTINGS	RESERVED	FILTER_SHAPE		RESERVED	IIR_WR		MUTE		
8 / 0x08	GPIO CONFIGURATION	RESERVED				GPIO1_CFG				
9 / 0x09	RESERVED	RESERVED FOR REVISION V								
10 / 0x0A	MASTER MODE CONTROL	MASTER_CLK_ENABLE	CLOCK_DIVIDER_SELECT		SYNC_MODE	STOP_DIV				
11 / 0x0B	CHANNEL MAPPING	RESERVED	SPDIF_SEL			CH2_ANALOG_SWAP	CH1_ANALOG_SWAP	CH2_SEL	CH1_SEL	
12 / 0x0C	DPLL/ASRC SETTINGS	DPLL_BW_I2S				DPLL_BW_DSD				
13 / 0x0D	THD COMPENSATION	RESERVED	BYPASS_THD	RESERVED						
14 / 0x0E	SOFT START SETTINGS	SOFT_START	SOFT_START_ON_LOCK	MUTE_ON_LOCK	SOFT_START_TIME					
15 / 0x0F	VOLUME 1	VOLUME 1								
16 / 0x10	VOLUME 2	VOLUME 2								
17 / 0x11	MASTER TRIM	MASTER_TRIM								
18 / 0x12										
19 / 0x13										
20 / 0x14										
21 / 0x15	GPIO INPUT SELECTION & OSF BYPASS	GPIO_INPUT_SEL2		GPIO_INPUT_SEL1		RESERVED	BYPASS_IIR	RESERVED	BYPASS_OSF	
22 / 0x16	2ND HARMONIC COMPENSATION COEFFICIENTS	THD_COMP_C2								
23 / 0x17										
24 / 0x18	3RD HARMONIC COMPENSATION COEFFICIENTS	THD_COMP_C3								
25 / 0x19										
26 / 0x1A	PROGRAMMABLE FILTER ADDRESS	PROG_COEFF_STAGE	PROG_COEFF_ADDR							
27 / 0x1B	PROGRAMMABLE FILTER COEFFICIENT	PROG_COEFF								
28 / 0x1C										
29 / 0x1D										
30 / 0x1E	PROGRAMMABLE FILTER CONTROL	RESERVED				EVEN_STAGE2_COEFF	PROG_COEFF_WE	PROG_COEFF_EN		
Read Only										
64 / 0x40	CHIP STATUS	RESERVED		REVISION	CHIP_ID			AUTOMUTE_STATUS	LOCK_STATUS	
65 / 0x41	GPIO STATUS	RESERVED								
66 / 0x42	DPLL RATIO	DPLL_NUM								
67 / 0x43										
68 / 0x44										
69 / 0x45										
70-93 / 0x46-0x5D	CHANNEL STATUS	SPDIF CHANNEL STATUS								



REGISTER SETTINGS

Register #0: System Settings

8 bit, Read-Write Register, Default = 0x00

Bits	[7]	[6]	[5]	[4]	[3]	[2]	[1]	[0]
Mnemonic	osc_drv				reserved *			soft_reset
Default	0	0	0	0	0	0	0	0

Bit	Mnemonic	Description
[7:4]	osc_drv	Oscillator drive specifies the bias current to the oscillator pad. <ul style="list-style-type: none"> 4'b0000: full bias (default) 4'b1000: 3/4 bias 4'b1100: 1/2 bias 4'b1110: 1/4 bias 4'b1111: shut down the oscillator Other settings: reserved It is recommended to use the default setting.
[3:1]	reserved *	
[0]	soft_reset	1'b0 is normal operation (default) 1'b1 resets chip

* All Reserved Bits in Register #0 must be set to the indicated logic level to ensure correct device operation.

Register #1: Input Configuration

8 bit, Read-Write Register, Default = 0x8C

Bits	[7]	[6]	[5]	[4]	[3]	[2]	[1]	[0]
Mnemonic	i2s_length	i2s_mode	auto_input_select		input_select			
Default	1	0	0	0	1	1	0	0

Bit	Mnemonic	Description
[7:6]	i2s_length	2'd0 = 16bit 2'd1 = 24bit 2'd2 or 2'd3 = 32bit (default)
[5:4]	i2s_mode	2'd0 = I ² S (default) 2'd1 = LJ mode 2'd2 = I ² S 2'd3 = LJ mode
[3:2]	auto_input_select	2'd0 = 'input select', 2'd1 = I ² S or DSD, 2'd2 = I ² S or SPDIF, 2'd3 = I ² S, SPDIF or DSD (default)
[1:0]	input_select	2'd0 = I ² S (default) 2'd1 = SPDIF 2'd2 = reserved 2'd3 = DSD

New product version is available in ES9020Q

ES9016K2M Datasheet



Register #2: Reserved

8 bit, Read-Write Register, Default = 0x18

Bits	[7]	[6]	[5]	[4]	[3]	[2]	[1]	[0]
Mnemonic	Reserved							
Default	0	0	0	1	1	0	0	0

Register #3: Reserved

8 bit, Read-Write Register, Default = 0x10

Bits	[7]	[6]	[5]	[4]	[3]	[2]	[1]	[0]
Mnemonic	Reserved							
Default	0	0	0	1	0	0	0	0

Register #4: Soft Volume Control 1 (Automute Time)

8 bit, Read-Write Register, Default = 0x00

Bits	[7]	[6]	[5]	[4]	[3]	[2]	[1]	[0]
Mnemonic	automute_time							
Default	0	0	0	0	0	0	0	0

Bit	Mnemonic	Description
[7:0]	automute_time	Default of 8'd0 (Automute Disabled) Time in Seconds = 2096896 / (automute_time x DATA_CLK) with DATA_CLK in Hz

Register #5: Soft Volume Control 2 (Automute Level)

8 bit, Read-Write Register, Default = 0x68

Bits	[7]	[6]	[5]	[4]	[3]	[2]	[1]	[0]
Mnemonic	automute_loopback	automute_level						
Default	0	1	1	0	1	0	0	0

Bit	Mnemonic	Description
[7]	automute_loopback	1'b0 disables automute_loopback (default) 1'b1 ramps to -infinity on automute
[6:0]	automute_level	The level (in 1dB increments) of the automute, default of 7'd104

New product version is available in ES9020Q



Register #6: Soft Volume Control 3 and De-emphasis

8 bit, Read-Write Register, Default = 0x4A

Bits	[7]	[6]	[5]	[4]	[3]	[2]	[1]	[0]
Mnemonic	spdif_auto_deemph	deemph_bypass	deemph_sel	reserved *	vol_rate			
Default	0	1	0	0	1	0	1	0

Bit	Mnemonic	Description
[7]	spdif_auto_deemph	1'b0 disables automatic de-emphasis select in SPDIF mode (default) 1'b1 enables automatic de-emphasis select in SPDIF mode
[6]	deemph_bypass	1'b0 enables de-emphasis filters 1'b1 disabled de-emphasis filters (default)
[5:4]	deemph_sel	2'b00 = 32kHz (default) 2'b01 = 44.1kHz 2'b10 = 48kHz 2'b11 = RESERVED
[3]	reserved *	Must be left as 1'b1 for normal operation
[2:0]	vol_rate	3'd2 by default Sets the volume ramp rate to $0.0078125 \times fs / 2^{(vol_rate-5)}$ dB/s

* All Reserved Bits in Register #6 must be set to the indicated logic level to ensure correct device operation.

Register #7: General Settings

8 bit, Read-Write Register, Default = 0x80

Bits	[7]	[6]	[5]	[4]	[3]	[2]	[1]	[0]
Mnemonic	reserved	filter_shape	reserved *	iir_bw	mute			
Default	1	0	0	0	0	0	0	0

Bit	Mnemonic	Description
[7]	reserved *	
[6:5]	filter_shape	2'd0 = fast rolloff (default) 2'd1 = slow rolloff 2'd2 = minimum phase 2'd3 = reserved
[4]	reserved	
[3:2]	iir_bw	2'd0 = $1.0757 \times fs$ or 47.44kHz ($fs = 44.1kHz$) - Normal mode (default) 2'd1 = $1.1338 \times fs$ or 50kHz ($fs = 44.1kHz$) 2'd2 = $1.3605 \times fs$ or 60kHz ($fs = 44.1kHz$) 2'd3 = $1.5873 \times fs$ or 70kHz ($fs = 44.1kHz$)
[1:0]	mute	This is a soft mute, which uses the ramping volume control. mute[0] <ul style="list-style-type: none"> 1'b0: Channel 1 (default of left channel) unmuted (default) 1'b1: Channel 1 (default of left channel) muted mute[1] <ul style="list-style-type: none"> 1'b0: Channel 2 (default of right channel) unmuted (default) 1'b1: Channel 2 (default of right channel) muted

* All Reserved Bits in Register #7 must be set to the indicated logic level to ensure correct device operation.

New product version is available in ES9020Q

ES9016K2M Datasheet



Register #8: GPIO Configuration

8 bit, Read-Write Register, Default = 0x10

Bits	[7]	[6]	[5]	[4]	[3]	[2]	[1]	[0]
Mnemonic	reserved				gpio1_cfg			
Default	0	0	0	1	0	0	0	0

Bit	Mnemonic	Description
[7:4]	reserved	
[3:0]	gpio1_cfg	Set GPIO 1 configuration Default to 4'd0 (Automute Status). See GPIO Configuration Table below for meaning of all settings.

GPIO Configuration Table

Setting	Direction	GPIO Function
4'd0	Output	Automute status (active high) – asserted when Automute condition is met
4'd1	Output	DPLL Lock status (active high) – asserted when DPLL is in lock
4'd2	Output	Minimum Volume (active high) - asserted when volume of both the left and right channels has ramped to its minimum value (–127.5dB).
4'd3	Output	MCLK
4'd4	Output	DPLL Lock interrupt (active high) - asserted when DPLL Lock status changes state - reading register 64 clears the interrupt
4'd5	Output	Automute Interrupt (active high) - asserted when Automute status changes state - reading register 64 clears the interrupt
4'd6	Output	DPLL Lock or Automute interrupt (active high) - asserted when DPLL Lock or Automute status changes state - reading register 64 clears the interrupt
4'd7	Output	Output low
4'd8	Input	Use as input pin - pin status can be read from register 65.
4'd9	Input	Input Selection - uses the GPIO as an input select based on register 21
4'd15	Output	Output high

Register #9: Reserved

8 bit, Read-Write Register, Default = 0x22

Bits	[7]	[6]	[5]	[4]	[3]	[2]	[1]	[0]
Mnemonic	Reserved for Revision V							
Default	0	0	0	0	0	0	0	0

New product version is available in ES9020Q



ES9016K2M Datasheet

Register #10: Master Mode Control

8 bit, Read-Write Register, Default = 0x5

Bits	[7]	[6]	[5]	[4]	[3]	[2]	[1]	[0]
Mnemonic	master_clock_enable	clock_divider_select	sync_mode	stop_div				
Default	0	0	0	0	0	1	0	1

Bit	Mnemonic	Description
[7]	master_clock_enable	1'b0 disables master mode (default) 1'b1 enables master mode (driving Bit clock and Frame Clock)
[6:5]	clock_divider_select	2'b00: Bit Clock frequency = MCLK / 4 (default) 2'b01: Bit Clock frequency = MCLK / 8 2'b10: Bit Clock frequency = MCLK / 16 2'b11: Bit Clock frequency = MCLK / 16 Frame Clock frequency = Bit Clock frequency / 64
[4]	sync_mode	1'b1 to enable quick lock if the fs and MCLK are synchronous and MCLK is 128 x FSR. 1'b0 for normal operation of the DPLL and ASRC. Note: quick lock can only be used in PCM normal mode.
[3:0]	stop_div	Sets the number of FSR edges that must occur before the DPLL and ASRC can lock on to the incoming signal. 4'd0 = 16384 FSR edges 4'd1 = 8192 FSR edges 4'd2 = 5461 FSR edges 4'd3 = 4096 FSR edges 4'd4 = 3276 FSR edges 4'd5 = 2730 FSR edges (default) 4'd6 = 2340 FSR edges 4'd7 = 2048 FSR edges 4'd8 = 1820 FSR edges 4'd9 = 1638 FSR edges 4'd10 = 1489 FSR edges 4'd11 = 1365 FSR edges 4'd12 = 1260 FSR edges 4'd13 = 1170 FSR edges 4'd14 = 1092 FSR edges 4'd15 = 1024 FSR edges

For correct operation, master mode should only be enabled when the DAC's input mode is set to I²S, and when i2s_length is set to 32-bit and i2s_mode is set to I²S in register 1.

When master mode is enabled, the DATA_CLK pin will output Bit Clock and the DATA1 pin will output Frame Clock at frequencies specified by clock divider select.

For compatibility with Rev. W, or when PCM data with FSR > 96kHz is used, stop_div should be set to 4'd0 (16384 FSR edges).

New product version is available in ES9020Q

ES9016K2M Datasheet



Register #11: Channel Mapping

8 bit, Read-Write Register, Default = 0x02

Bits	[7]	[6]	[5]	[4]	[3]	[2]	[1]	[0]
Mnemonic	reserved *	spdif_sel			ch2_analog_swap	ch1_analog_swap	ch2_sel	ch1_sel
Default	0	0	0	0	0	0	1	0

Bit	Mnemonic	Description
[7]	reserved *	
[6:4]	spdif_sel	select the spdif data source 3'd0 = DATA_CLK (default) 3'd1 = DATA2 3'd2 = DATA1 3'd3 = GPIO1 3'd4-7: reserved
[3]	ch2_analog_swap	1'b0 = normal operation (default) 1'b1 = swap dac and dacb
[2]	ch1_analog_swap	1'b0 = normal operation (default) 1'b1 = swap dac and dacb
[1]	ch2_sel	1'b0 = left 1'b1 = right (default)
[0]	ch1_sel	1'b0 = left (default) 1'b1 = right

* All Reserved Bits in Register #11 must be set to the indicated logic level to ensure correct device operation.

Left and Right channels can be reversed using Register #11.

New product version is available in ES9020Q



ES9016K2M Datasheet

Register #12: DPLL/ASRC Settings

8 bit, Read-Write Register, Default = 0x5A

Bits	[7]	[6]	[5]	[4]	[3]	[2]	[1]	[0]
Mnemonic	dpll_bw_i2s				dpll_bw_dsd			
Default	0	1	0	1	1	0	1	0

Bit	Mnemonic	Description
[7:4]	dpll_bw_i2s	DPLL bandwidth setting for I ² S and SPDIF modes (16 settings) 4'b0000 : OFF 4'b0001 : Lowest Bandwidth 4'b0101 : (default) 4'b1010 : 4'b1111 : Highest Bandwidth
[3:0]	dpll_bw_dsd	DPLL bandwidth setting for DSD mode (16 settings) 4'b0000 : OFF 4'b0001 : Lowest Bandwidth 4'b0101 : 4'b1010 : (default) 4'b1111 : Highest Bandwidth

Register #13: THD Compensation

8 bit, Read-Write Register, Default = 0x40

Bits	[7]	[6]	[5]	[4]	[3]	[2]	[1]	[0]
Mnemonic	reserved *	bypass_thd	reserved *					
Default	0	1	0	0	0	0	0	0

Bit	Mnemonic	Description
[7]	reserved *	
[6]	bypass_thd	1'b0: enable THD compensation <ul style="list-style-type: none"> output = input + (input²) x thd_comp_c2 + (input³) x thd_comp_c3 thd_comp_c2 is stored in registers 23-22 (16 bits signed) (register 23 stores MSBs) thd_comp_c3 is stored in registers 25-24 (16 bits signed) (register 25 stores MSBs) 1'b1: disable THD compensation (default) <ul style="list-style-type: none"> PCM mode: output = input; DSD mode: output = input / 2
[5:0]	reserved	

* All Reserved Bits in Register #13 must be set to the indicated logic level to ensure correct device operation. THD compensation can be used to reduce the 2nd and 3rd harmonic distortion introduced by external output drivers. A system level tuning is required to arrive at the optimum coefficients for thd_comp_c2 and thd_comp_c3.

Notes:

- To get the same gain (output = input) for PCM and DSD modes without THD compensation, bypass_thd should be set to 1'b0 with thd_comp_c2 and thd_comp_c3 set to 16'd0 (default)
- Erroneous compensation can lead to higher distortion than the one without compensation. If accurate tuning cannot be performed, thd_comp_c2 and thd_comp_c3 should be set to 16'd0 (default) if bypass_thd is set to 1'b0.

New product version is available in ES9020Q

ES9016K2M Datasheet



Register #14: Soft Start Settings

8 bit, Read-Write Register, Default = 0x8A

Bits	[7]	[6]	[5]	[4]	[3]	[2]	[1]	[0]
Mnemonic	soft_start	soft_start_on_lock	mute_on_lock	soft_start_time				
Default	1	0	0	0	1	0	1	0

Bit	Mnemonic	Description
[7]	soft_start	1'b0: Ramp the output stream to ground 1'b1: Normal operation (default) - ramp the output stream to $\frac{1}{2} \times AVCC_L/R$
[6]	soft_start_on_lock	1'b0: Do not force output low when lock is lost (default) 1'b1: Force output low when lock is lost
[5]	mute_on_lock	1'b0: Do not force a mute when lock is lost (default) 1'b1: Force a mute when lock is lost
[4:0]	soft_start_time	Time for soft start ramp = $4096 \times 2^{(\text{soft_start_time}+1)} / \text{MCLK}$ seconds (where MCLK is measured in Hz). The valid range of soft-start_time is from 0 to 20.

Register #15: Volume 1 (usually selected for the Left Channel, but can be reversed using Register #11)

8 bit, Read-Write Register, Default = 0x00

Bits	[7]	[6]	[5]	[4]	[3]	[2]	[1]	[0]
Mnemonic	volume1							
Default	0	0	0	0	0	0	0	0

Bit	Mnemonic	Description
[7:0]	volume1	Default to 8'd0 0dB to -127.5dB in 0.5dB steps

Register #16: Volume 2 (usually selected for the Right Channel, but can be reversed using Register #11)

8 bit, Read-Write Register, Default = 0x00

Bits	[7]	[6]	[5]	[4]	[3]	[2]	[1]	[0]
Mnemonic	volume2							
Default	0	0	0	0	0	0	0	0

Bit	Mnemonic	Description
[7:0]	volume2	Default to 8'd0 0dB to -127.5dB in 0.5dB steps

Register #20-17: Master Trim

32 bit, Read-Write Register, Default = 32'h7ffffff. Reg 20 are the MSB's, Reg 17 are the LSB's.

Bits	[31:0]
Mnemonic	master_trim
Default	32'h7ffffff

This is a 32 bit value that sets the 0dB level for all volume controls. This is a signed number, so it should never exceed 32'h7ffffff (which is $2^{31} - 1$).

New product version is available in ES9020Q



ES9016K2M Datasheet

Register #21: GPIO Input Selection and OSF Bypass

8 bit, Read-Write Register, Default = 0x00

Bits	[7:6]	[5:4]	[3]	[2]	[1]	[0]
Mnemonic	gpio_input_sel2	gpio_input_sel1	reserved *	bypass_iir	reserved *	bypass_osf
Default	0	0	0	0	0	0

Bit	Mnemonic	Description
[7:6]	gpio_input_sel2	Selects which input will be selected when GPIOX = 1'b1 2'd0 = I ² S data (default) 2'd1 = SPDIF data 2'd2 = reserved 2'd3 = DSD data
[5:4]	gpio_input_sel1	Selects which input will be selected when GPIOX = 1'b0 2'd0 = I ² S data (default) 2'd1 = SPDIF data 2'd2 = reserved 2'd3 = DSD data
[3]	reserved *	
[2]	bypass_iir	1'b0 = Use the IIR filter (default) 1'b1 = Bypass the IIR filter.
[3]	reserved *	
[0]	bypass_osf	1'b0 = Use the interpolating 8x FIR filter (default) 1'b1 = Bypass the interpolating 8x FIR filter. Note: Bypassing the interpolating filter requires that the input data be oversampled at 8x fs by an external oversampling filter.

* All Reserved Bits in Register #21 must be set to the indicated logic level to ensure correct device operation.

Note: Any of the GPIO can be configured to be used as an input select. This allows an external MCU or controller to set the input type by setting the GPIO to either logic high (1'b1) or logic low (1'b0). To set this feature, the first step is to enable one of the GPIO as an input select by setting gpio_cfg to 4'd9. Once a GPIO is configured as an input select it has the ability to select between two different inputs. The first input (logic low) is set via register 21[5:4]. The second input (logic high) is set via register 21[7:6].

Register #23-22: 2nd Harmonic Compensation Coefficients

16 bit, Read-Write Register, Default = 0x0000 (no compensation). Register #23 is MSB. See Register #13 for more details.

Bits	[15:0]
Mnemonic	Thd_comp_c2
Default	16'd0

Register #25-24: 3rd Harmonic Compensation Coefficients

16 bit, Read-Write Register, Default = 0x0000 (no compensation). Register #25 is MSB. See Register #13 for more details.

Bits	[15:0]
Mnemonic	Thd_comp_c3
Default	16'd0

New product version is available in ES9020Q

ES9016K2M Datasheet



Register #26: Programmable Filter Address

8 bit, Read-Write Register, Default = 0x00

Bits	[7]	[6:0]
Mnemonic	prog_coeff_stage	prog_coeff_addr
Default	0	0 0 0 0 0 0 0

Bit	Mnemonic	Description
[7]	prog_coeff_stage	Selects which stage of the filter to write. 1'b0 = Stage 1 of the oversampling filter (128 coefficients) 1'b1 = Stage 2 of the oversampling filter (16 coefficients)
[6:0]	prog_coeff_addr	Selects the coefficient address when writing custom coefficients for the oversampling filter.

Register #29-27: Programmable Filter Coefficient

8 bit, Read-Write Register, Default = 0x000000

Bits	[23:0]
Mnemonic	prog_coeff
Default	24'd0

Bit	Mnemonic	Description
[23:0]	prog_coeff	A 24bit filter coefficients that will be written to address 'prog_coeff_addr'.

Register #30: Programmable Filter Control

8 bit, Read-Write Register, Default = 0x00

Bits	[7:3]	[2]	[1]	[0]
Mnemonic	reserved *	even_stage2_coeff	prog_coeff_we	prog_coeff_en
Default	0 0 0 0 0	0	0	0

Bit	Mnemonic	Description
[7:3]	reserved *	
[2]	even_stage2_coeff	Sets the type of symmetry of the stage 2 programmable filter. 1'b0 = Uses a sine symmetric filter (27 coefficients). 1'b1 = Uses a cosine symmetric filter (28 coefficients).
[1]	prog_coeff_we	1'b0 = Disable writing to the custom filter coefficients. 1'b1 = Enable writing to the custom filter coefficients. Note: When set to 1'b1 the custom filter will be bypassed regardless of the state of register 21[0].
[0]	prog_coeff_en	1'b0 = Use one of the built-in oversampling filters. 1'b1 = Use the custom oversampling filter. Note: The custom filter is not programmed to anything on reset, valid coefficients must be written to the filter before enabling.

* All Reserved Bits in Register #30 must be set to the indicated logic level to ensure correct device operation.

Note: even_stage2_coeff sets the type of symmetry used by the second stage filter. The actual RAM is 16 coefficients, but only the first 14 coefficients are used when applying the oversampling filter. The first 14 coefficients are mirrored using either sine or cosine symmetry, resulting in a filter length of either 27 or 28 taps. This means that the second stage RAM should only contain half of the impulse response of the second stage filter, and the impulse peak value will be contained in the 14th coefficient. Also note that, due to the symmetry of the filter, only linear phase filters may be used in the second stage.

New product version is available in ES9020Q



ES9016K2M Datasheet

Register #64: Chip Status

8 bit, Read-Only Register

Bits	[7]	[6]	[5]	[4]	[3]	[2]	[1]	[0]
Mnemonic	Reserved		revision	chip_id		automute_status		lock_status

Bit	Mnemonic	Description
[7:6]	Reserved	
[5]	revision	1'b0 => revision W. 1'b1 => revision V.
[4:2]	chip_id	3'd6 => ES9016K2M
[1]	automute_status	1'b0 => Automute condition is inactive. 1'b1 => Automute condition is active.
[0]	lock_status	1'b0 => The Jitter Eliminator is not locked to an incoming signal. 1'b1 => The Jitter Eliminator is locked to an incoming signal.

Register #65

8 bit, Read-Only Register

Bits	[7]	[6]	[5]	[4]	[3]	[2]	[1]	[0]
Mnemonic	reserved						gpio_I[1:0]	

Bit	Mnemonic	Description
[7:2]	reserved	
[0]	gpio_I[0]	Status of pin GPIO1

Register #69-66: DPLL Ratio

32 bit, Read-Only Register. Reg 69 are the MSB's, Reg 66 are the LSB's

Bits	[31:0]
Mnemonic	dpll_num

This is a read-only 32bit value that can be used to calculate the sample rate. The raw sample rate (FSR) can be calculated using: $FSR = (DPLL_NUM \times F_{MCLK}) / 2^{32}$.

Note that the DPLL number (register 66-69) should be read from LSB to MSB as it is latched on the LSBs (register 66).

Register #93-70: Channel Status

Reg 93 are the MSB's, Reg 70 are the LSB's Format is [191:0]

These registers allow read back of the SPDIF channel status. The status definition is different for the consumer configuration and professional configuration. Please refer to the following two tables for details.

New product version is available in ES9020Q

ES9016K2M Datasheet



SPDIF CHANNEL STATUS - Consumer configuration									
Address Offset	[7]	[6]	[5]	[4]	[3]	[2]	[1]	[0]	
0	Reserved	Reserved	0:2Channel 1:4Channel	Reserved	0:No-Preemph 1:Preemph	0:CopyRight 1:Non-CopyRight	0:Audio 1:Data	0:Consumer 1:Professional	
1	Category Code 0x00: General 0x01: Laser-Optical 0x02: D/D Converter 0x03: Magnetic 0x04: Digital Broadcast 0x05: Musical Instrument 0x06: Present A/D Converter 0x08: Solid State Memory 0x16: Future A/D Converter 0x19: DVD 0x40: Experimental								
2	Channel Number 0x0: Don't Care 0x1: A (Left) 0x2: B (Right) 0x3: C 0x4: D 0x5: E 0x6: F 0x7: G 0x8: H 0x9: I 0xA: J 0xB: K 0xC: L 0xD: M 0xE: N 0xF: O				Source Number 0x0: Don't Care 0x1: 1 0x2: 2 0x3: 3 0x4: 4 0x5: 5 0x6: 6 0x7: G 0x8: 8 0x9: 9 0xA: 10 0xB: 11 0xC: 12 0xD: 13 0xE: 14 0xF: 15				
3	Reserved	Reserved	Clock Accuracy 0x0:Level 2 +-1000ppm 0x1:Level 1 +-50ppm 0x2:Level 3 variable pitch shifted		Sample Frequency 0x0: 44.1k 0x2: 48k 0x3: 32k 0x4: 22.05k 0x6: 24k 0x8: 88.2k 0xA: 96k 0xC: 176.4k 0xE: 192k				
4	Reserved	Reserved	Reserved	Reserved	Word Length: If Word Field Size=0 If Word Field Size = 1 000=Not indicated 000=Not indicated 100 = 23bits 100 = 19bits 010 = 22bits 010 = 18bits 110 = 21bits 110 = 17bits 001 = 20bits 001 = 16bits 101 = 24bits 101 = 20bits			Word Field Size 0:Max 20bits 1:Max 24bits	
5-23	Reserved								

New product version is available in ES9020Q



ES9016K2M Datasheet

SPDIF CHANNEL STATUS - Professional configuration									
Address Offset	[7]	[6]	[5]	[4]	[3]	[2]	[1] [0]		
0	sampling frequency: 00: not indicated (or see byte 4) 10: 48kHz 01: 44.1kHz 11: 32kHz		lock: 0: locked 1: unlocked	emphasis: 000: Emphasis not indicated 001: No emphasis 011: CD-type emphasis 111: J-17 emphasis			0:Audio 1:Non-audio	0:Consumer 1:Professional	
1	User bit management: 0000: no indication 1000: 192-bit block as channel status 0100: As defined in AES18 1100: user-defined 0010: As in IEC60958-3 (consumer)				Channel mode: 0000: not indicated (default to 2 ch) 1000: 2 channel 0100: 1 channel (monophonic) 1100: primary / secondary 0010: stereo 1010: reserved for user applications 0110: reserved for user applications 1110: SCDSR (see byte 3 for ID) 0001: SCDSR (stereo left) 1001: SCDSR (stereo right) 1111: Multichannel (see byte 3 for ID)				
2	alignment level: 00: not indicated 10: -20dB FS 01: -18.06dB FS		Source Word Length: If max = 20bits If max = 24bits 000=Not indicated 1000=Not indicated 100 = 23bits 1100 = 19bits 010 = 22bits 010 = 18bits 110 = 21bits 110 = 17bits 001 = 20bits 1001 = 16bits 101 = 24bits 101 = 20bits		Use of aux sample word: 000: not defined, audio max 20 bits 100: used for main audio, max 24 bits 010: used for coord, audio max 20 bits 110: reserved				
3	Channel identification: if bit 7 = 0 then channel number is 1 plus the numeric value of bits 0-6 (bit reversed). if bit 7 = 1 then bits 4-6 define a multichannel mode and bits 0-3 (bit reversed) give the channel number within that mode.								
4	fs scaling: 0: no scaling 1: apply factor of 1 / 1.001 to value	Sample frequency (fs): 0000: not indicated 0001: 24kHz 0010: 96kHz 1001: 22.05kHz 1010: 88.2kHz 1011: 176.4kHz 0011: 192kHz 1111: User defined			Reserved	DARS (Digital audio reference signal): 00: not a DARS 01: DARS grade 2 (± 10 ppm) 10: DARS grade 1 (± 1 ppm) 11: Reserved			
5	Reserved								
6-9	alphanumerical channel origin: four-character label using 7-bit ASCII with no parity. Bits 55, 63, 71, 79 = 0.								
10-13	alphanumerical channel destination: four-character label using 7-bit ASCII with no parity. Bits 87, 95, 103, 111 = 0.								
14-17	local sample address code: 32-bit binary number representing the sample count of the first sample of the channel status block.								
18-21	time of day code: 32-bit binary number representing time of source encoding in samples since midnight								
22	reliability flags 0: data in byte range is reliable 1: data in byte range is unreliable								
23	CRCC 00000000: not implemented X: error check code for bits 0-183								

New product version is available in ES9020Q

ES9016K2M Datasheet



APPLICATION DIAGRAM

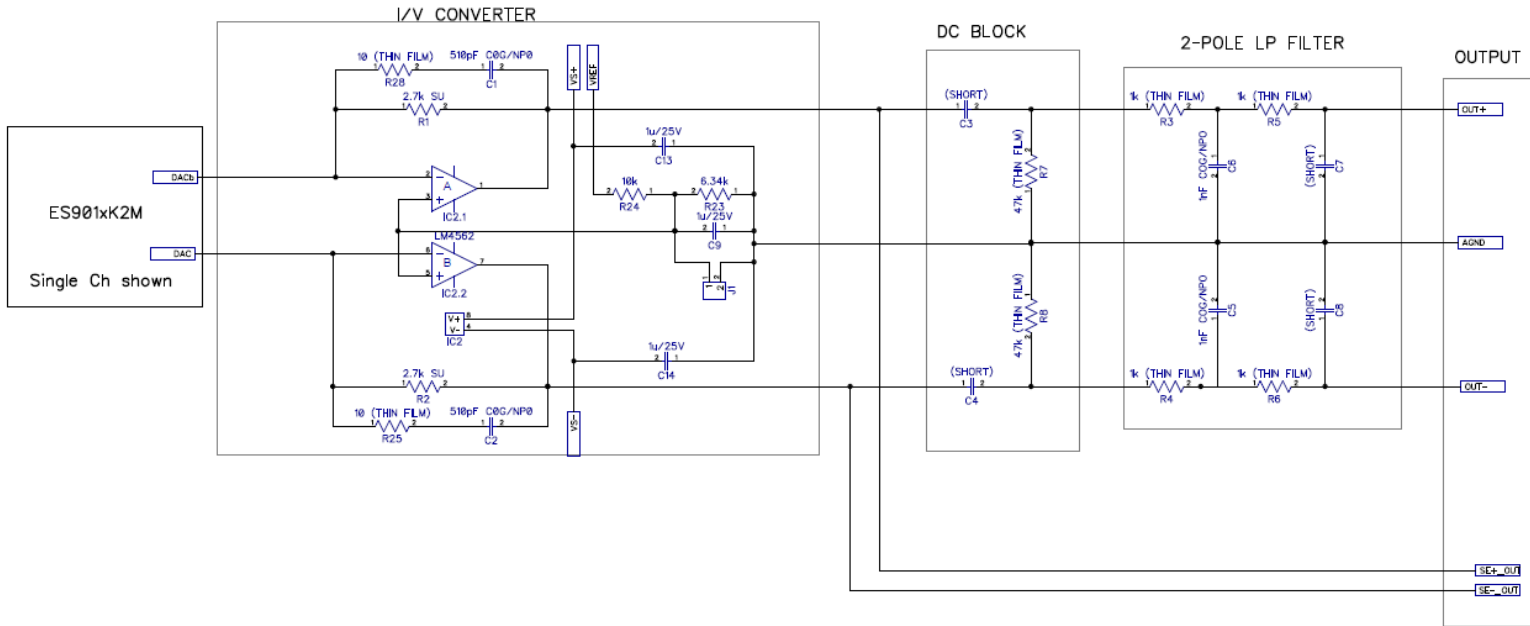

RECOMMENDED POWER-UP SEQUENCE

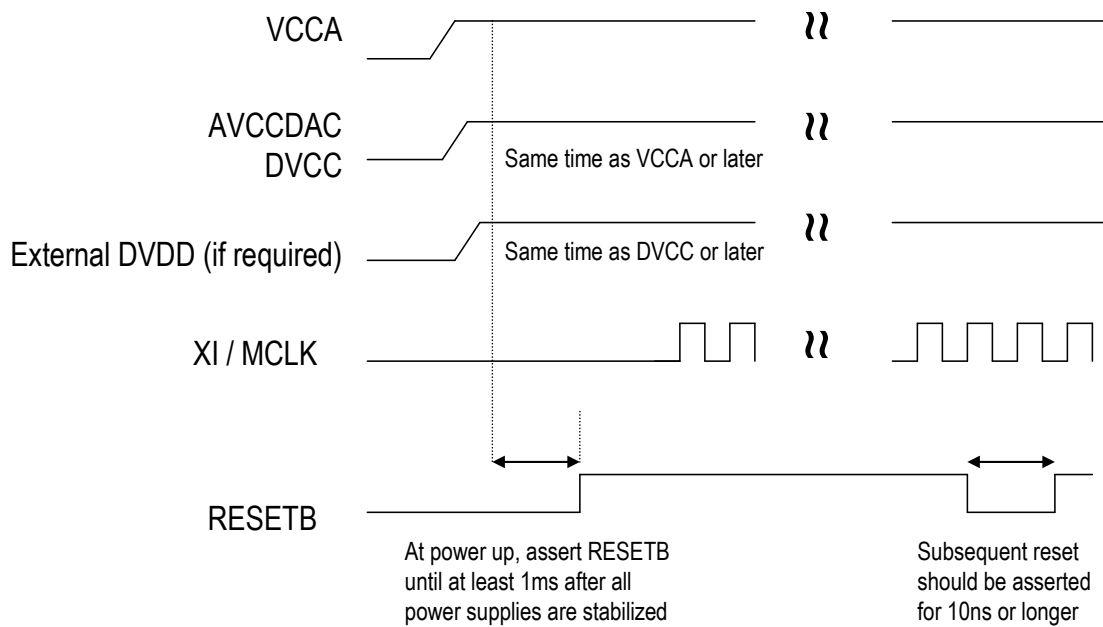

New product version is available in ES9020Q



ES9016K2M Datasheet

ABSOLUTE MAXIMUM RATINGS

PARAMETER	RATING
Storage temperature	-65°C to +105°C
Voltage range for digital input pins	-0.3V to DVCC+ 0.3V
ESD Protection	
Human Body Model (HBM)	2000V
Machine Model (MM)	200V

WARNING: Stresses beyond those listed under “Absolute Maximum Ratings” may cause permanent damage to the device. These are stress ratings only and functional operation of the device at these or any other conditions beyond those indicated under “recommended operating conditions” is not implied. Exposure to absolute-maximum-rated conditions for extended periods may affect device reliability.

WARNING: Electrostatic Discharge (ESD) can damage this device. Proper procedures must be followed to avoid ESD when handling this device.

RECOMMENDED OPERATING CONDITIONS

PARAMETER	SYMBOL	CONDITIONS
Operating temperature	T _A	-20°C to +70°C

Power Supply		Voltage	Current nominal (Note 1)	Current standby (Notes 1, 2)
Digital Power Supply Voltage	DVCC	+1.8V ± 5% +3.3V ± 5%	13.0mA 14.2mA	0mA 0mA
Internal Digital Core supply	DVDD	+1.2V (typical)		
External Digital Core Supply	DVDD	+1.3V ± 5% (Note 3)	50mA	
Analog Core Supply Voltage	VCCA (Note 4)	+3.3V ± 5% +1.8V ± 5%	0.8mA	0mA
Analog Power Supply Voltage	AVCCDAC (Note 4)	+3.3V ± 5% +1.8V ± 5%	8.0mA	0mA
Total Power		DVCC = +1.8V DVCC = +3.3V	≤ 36mW ≤ 59mW	< 1mW < 1mW

Notes:

- (1) fs = 44.1kHz, external MCLK = 22MHz, I²S input, DAC output connected to current-to-voltage converter, internal DVDD, all external supply voltages at nominal center values
- (2) With RESETB held low after setting the soft_start bit in register 14 to 1'b0 to fully ramp the DAC outputs to ground
- (3) Internal DVDD should be used except under the conditions described on page 7. External DVDD current measured at 192kHz sample rate and MCLK = 80MHz.
- (4) For correct operation, VCCA ≥ AVCCDAC.

DC ELECTRICAL CHARACTERISTICS

Symbol	Parameter	Minimum	Maximum	Unit	Comments
VIH	High-level input voltage	DVCC / 2 + 0.4		V	
VIL	Low-level input voltage		0.4	V	
VOH	High-level output voltage	DVCC - 0.2		V	IOH = 100μA
VOL	Low-level output voltage		0.2	V	IOL = 100μA

ES9016K2M Datasheet



XI / MCLK Timing

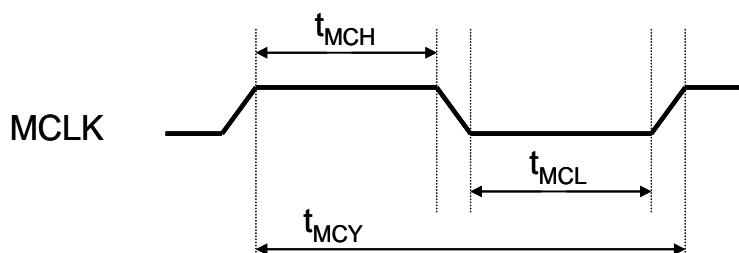

Parameter	Symbol	Min	Max	Unit
MCLK pulse width high	T_{MCH}	4.5		ns
MCLK pulse width low	T_{MCL}	4.5		ns
MCLK cycle time	T_{MCY}	10		ns
MCLK duty cycle		45:55	55:45	

Audio Interface Timing

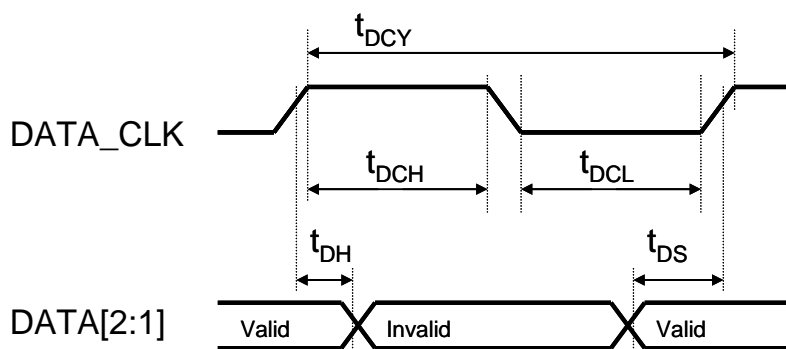

Parameter	Symbol	Min	Max	Unit
DATA_CLK pulse width high	t_{DCH}	4.5		ns
DATA_CLK pulse width low	t_{DCL}	4.5		ns
DATA_CLK cycle time	t_{DCY}	10		ns
DATA_CLK duty cycle		45:55	55:45	
DATA set-up time to DATA_CLK rising edge	t_{DS}	4.1		ns
DATA hold time to DATA_CLK rising edge	t_{DH}	2		ns

Notes:

- Audio data on DATA[2:1] are sampled at the rising edges of DATA_CLK and must satisfy the setup and hold time requirements relative to the rising edge of DATA_CLK
- For DSD Phase mode, the normal data (D0, D1, D2.. on p.10) must satisfy the setup and hold time requirements relative to the rising edge of DATA_CLK. The complimentary data ($\overline{D0}$, $\overline{D1}$, etc.) will be ignored.

New product version is available in ES9020Q



ES9016K2M Datasheet

ANALOG PERFORMANCE

Test Conditions (unless otherwise stated)

- $T_A = 25^\circ\text{C}$, AVCCDAC = VCCA = DVCC = 3.3V, internal DVDD with 4.7mF $\pm 20\%$ decoupling, $f_s = 44.1\text{kHz}$, MCLK = 27MHz & 32-bit data
- SNR/DNR: A-weighted over 20Hz-20kHz in averaging mode
THD+N: un-weighted over 20Hz-20kHz bandwidth

PARAMETER	CONDITIONS	MIN	TYP	MAX	UNIT
Resolution			32		Bits
MCLK (PCM normal mode)	Note *3	192FSR		Note *2	Hz
MCLK (PCM OSF bypass mode)		24FSR			
MCLK (DSD mode)		3FSR			
MCLK (SPDIF mode)		386FSR			
DYNAMIC PERFORMANCE					
DNR (differential current mode)	-60dBFS		122		dB-A
THD+N (differential current mode)	0dBFS		-110		dB
ANALOG OUTPUT					
Differential (+ or -) voltage out range (Note *4)	Full-scale out		3.05 (0.924 x AVCCDAC)		Vp-p
Differential (+ or -) voltage out offset (Note *4)	Bipolar zero out		1.65 (AVCCDAC / 2)		V
Differential (+ or -) current out range (Notes *1, *4)	Full-scale out		3.784		mA-p-p
Differential (+ or -) current out offset (Notes *1, *4)	Bipolar zero out to virtual ground at voltage Vg (V)		2.047 - (1000 x Vg) / 806		mA
Digital Filter Performance					
De-emphasis error				± 0.2	dB
Mute Attenuation			127		dB
PCM Filter Characteristics (Sharp Roll Off)					
Pass band	$\pm 0.003\text{dB}$			0.454fs	Hz
	-3dB			0.49fs	Hz
Stop band	< -115dB	0.546fs			Hz
Group Delay			35 / fs		s
PCM Filter Characteristics (Slow Roll Off)					
Pass band	$\pm 0.05\text{dB}$			0.308fs	Hz
	-3dB			0.454fs	Hz
Stop band	< -100dB	0.814fs			Hz
Group Delay			6.25 / fs		s
PCM Filter Characteristics (Minimum Phase)					
Pass band	$\pm 0.003\text{dB}$			0.454fs	Hz
	-3dB			0.49fs	Hz
Stop band	< -115dB	0.546fs			Hz

Notes:

- Differential (+ or -) current output is equivalent to a differential (+ or -) voltage source in series with an $806\Omega \pm 11\%$ resistor. The differential (+ or -) voltage source has a peak-to-peak output range of $0.924 \times \text{AVCCDAC} = 3.05\text{V}$ and an output offset of $\text{AVCCDAC} / 2 = 1.65\text{V}$.
- With internal DVDD, maximum MCLK frequency is 50MHz (DVCC = 1.8V), or 100MHz (DVCC = 3.3V) with an external +1.3V DVDD supply.
- Synchronous MCLK at 128 x FSR is also supported.
- Values are valid for AVCCDAC = 3.3V. For AVCCDAC = 1.8V, formulas should be used.

New product version is available in ES9020Q

ES9016K2M Datasheet



PCM DE-EMPHASIS FILTER RESPONSE (32kHz)

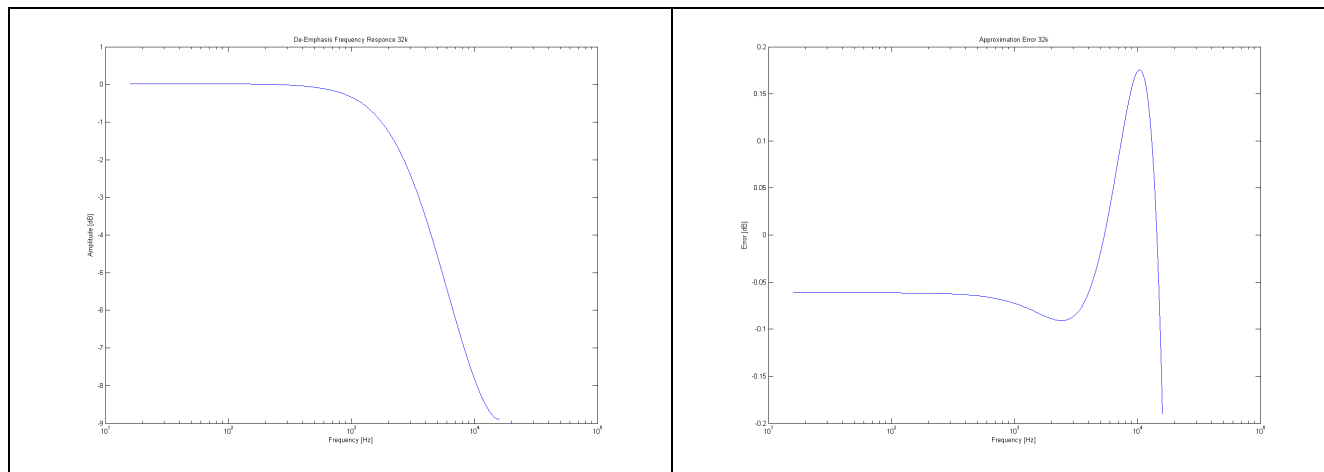

PCM DE-EMPHASIS FILTER RESPONSE (44.1kHz)

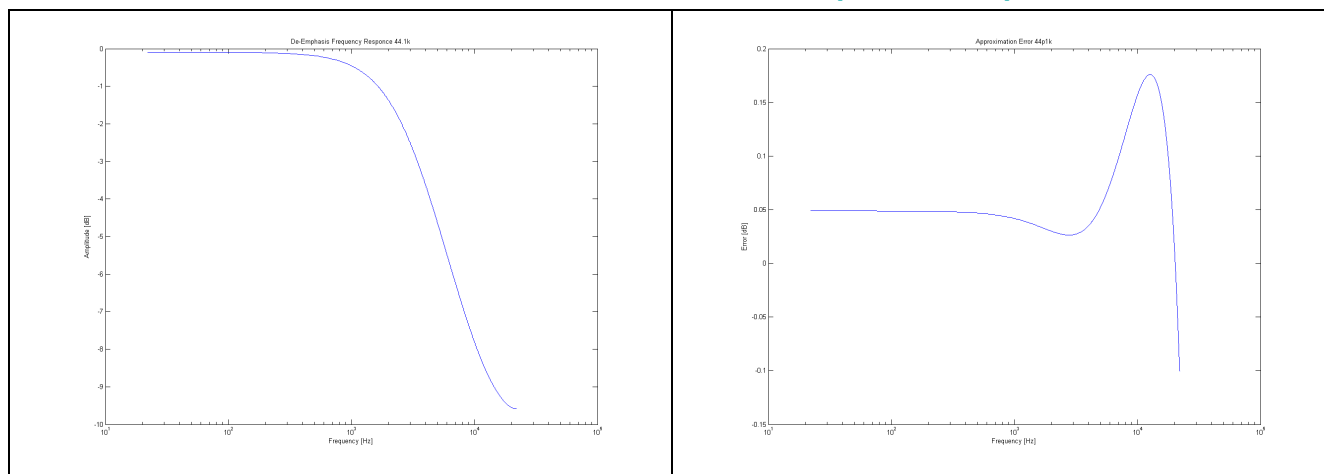

PCM DE-EMPHASIS FILTER RESPONSE (48kHz)

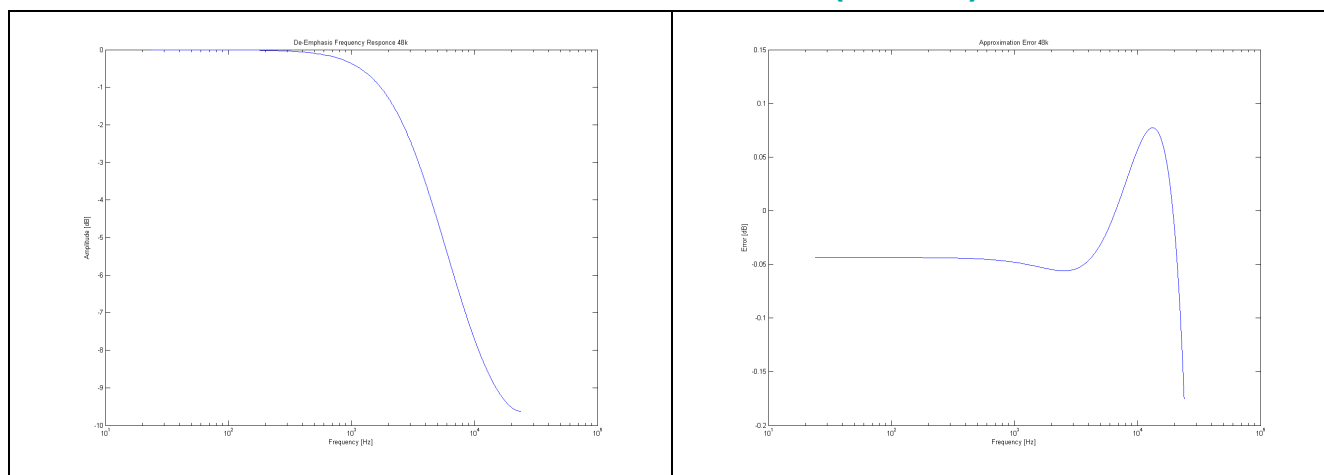

New product version is available in ES9020Q



ES9016K2M Datasheet

PCM FILTER FREQUENCY RESPONSE

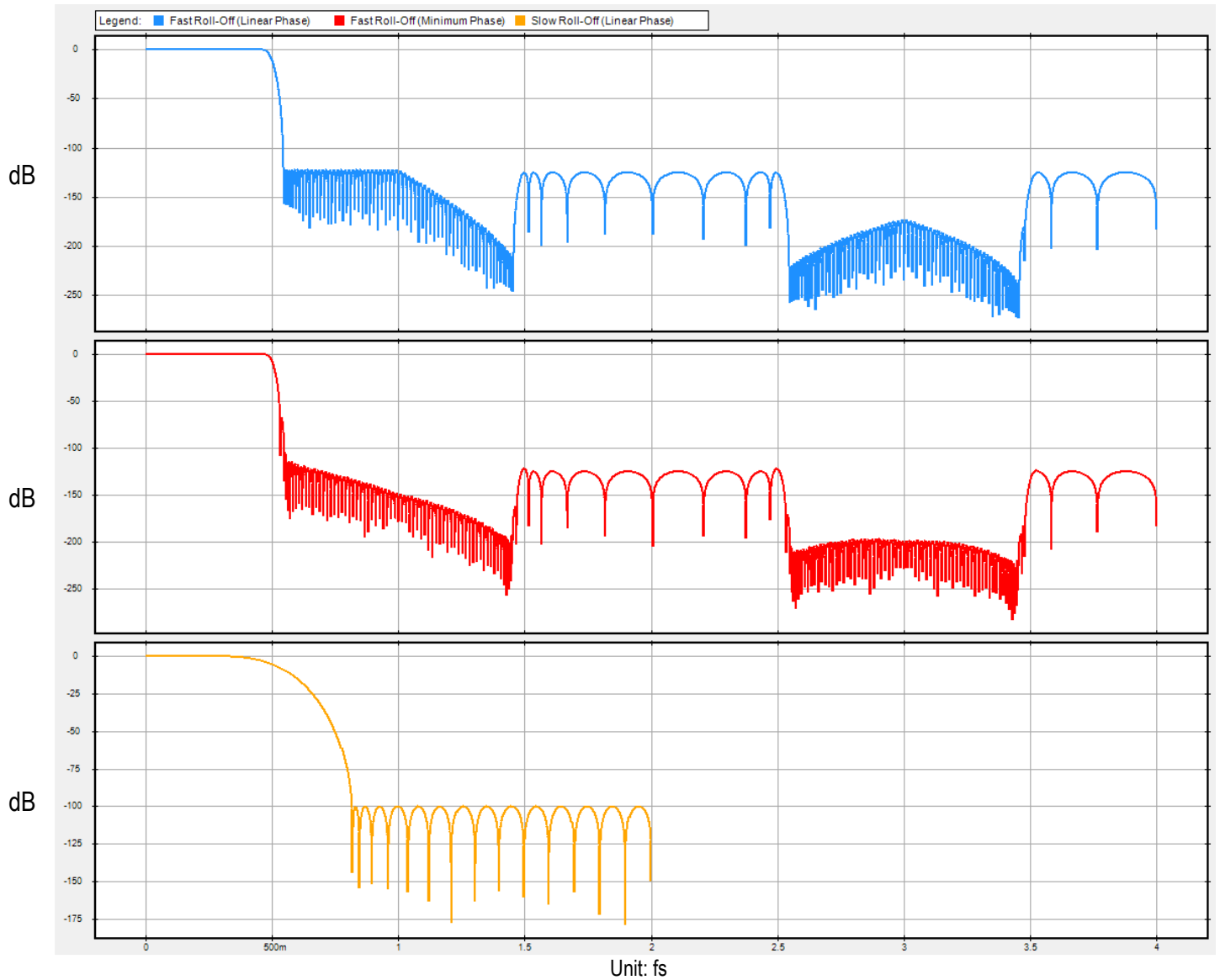

New product version is available in ES9020Q

ES9016K2M Datasheet



PCM FILTER IMPULSE RESPONSE

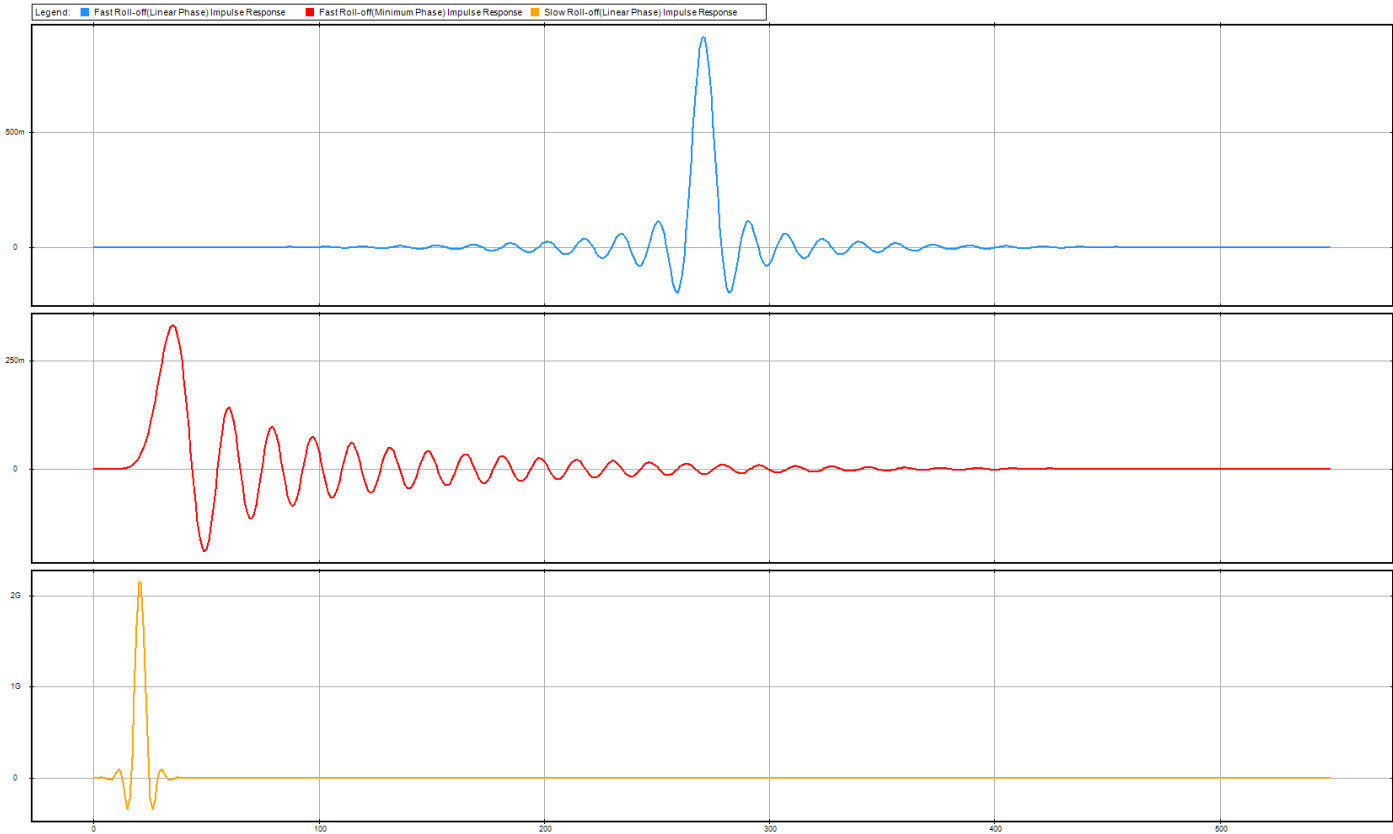

Unit: 1/fs (s)

New product version is available in ES9020Q



ES9016K2M Datasheet

DSD FILTER RESPONSE

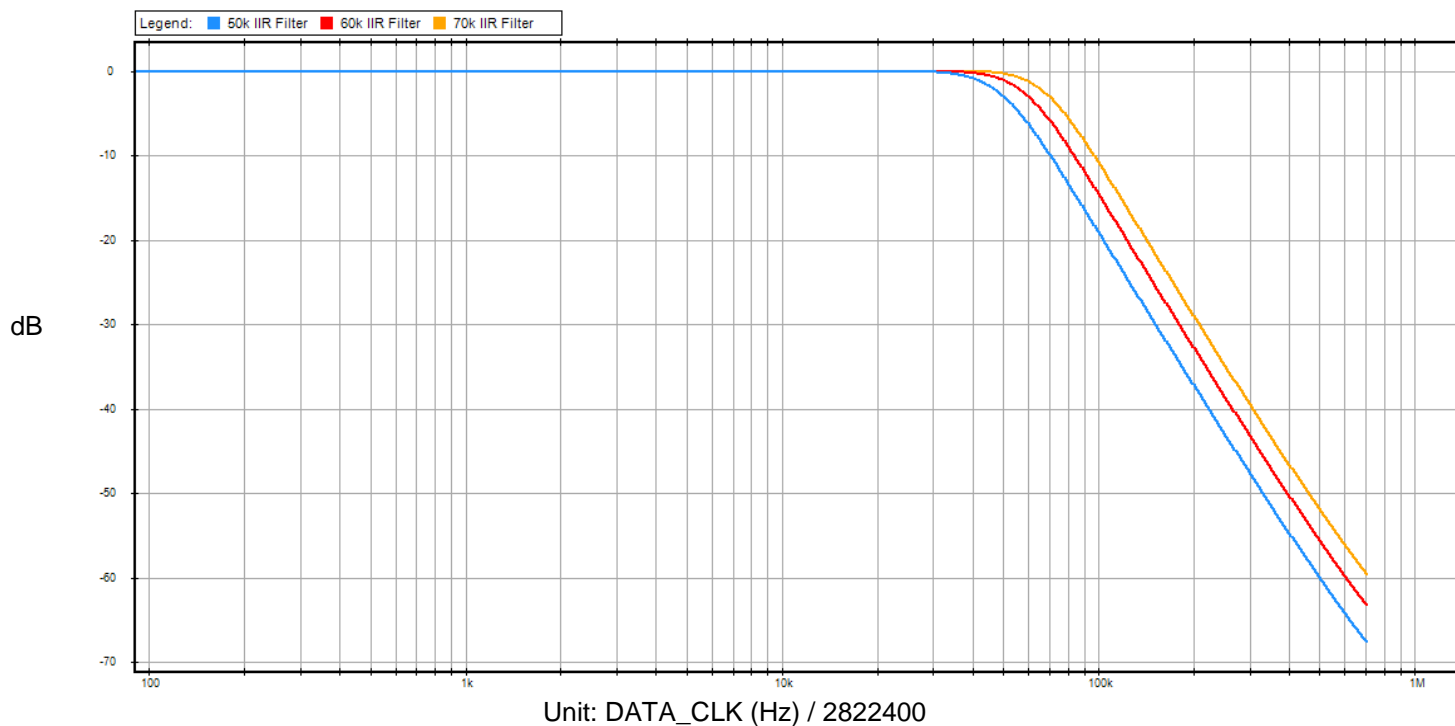

New product version is available in ES9020Q

ES9016K2M Datasheet



28-Pin QFN Mechanical Dimensions

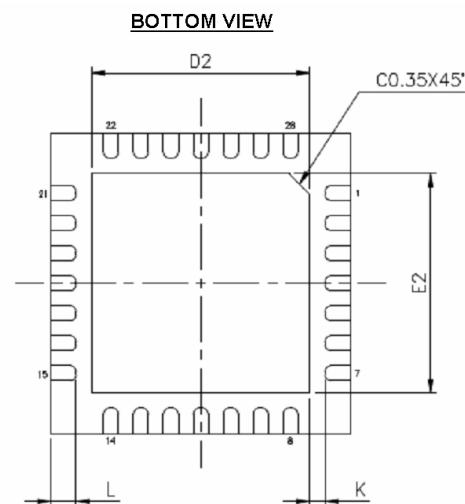
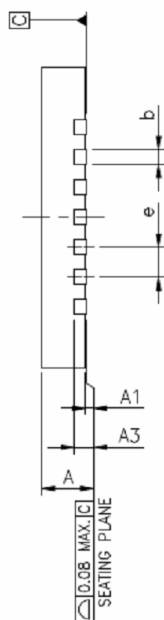
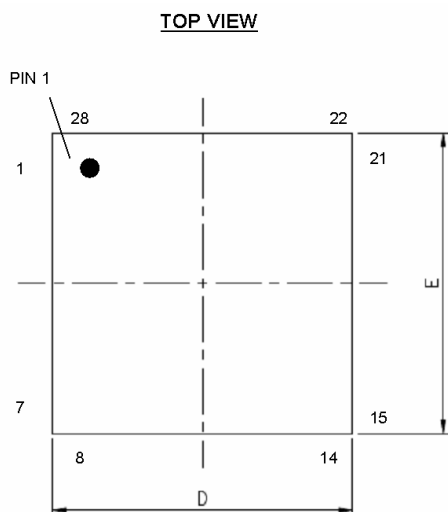

NOTES :

1. ALL DIMENSIONS ARE IN MILLIMETERS.
2. DIMENSION b APPLIES TO METALLIZED TERMINAL AND IS MEASURED BETWEEN 0.15mm AND 0.30mm FROM THE TERMINAL TIP. IF THE TERMINAL HAS THE OPTIONAL RADIUS ON THE OTHER END OF THE TERMINAL, THE DIMENSION b SHOULD NOT BE MEASURED IN THAT RADIUS AREA.
3. BILATERAL COPLANARITY ZONE APPLIES TO THE EXPOSED HEAT SINK SLUG AS WELL AS THE TERMINALS.

SYMBOLS	MIN.	NOM.	MAX.
A	0.70		0.90
A1	0.00	0.02	0.05
A3		0.203 REF.	
b	0.18	0.25	0.30
D		5.00 BSC	
E		5.00 BSC	
e		0.50 BSC	
K	0.20	—	—

PAD SIZE	E2			D2			L			LEAD FINISH	
	MIN.	NOM.	MAX.	MIN.	NOM.	MAX.	MIN.	NOM.	MAX.	Pure Tin	PPF
	2.50		3.60	2.50		3.60	0.50	0.55	0.60	V	X

New product version is available in ES9020Q



ES9016K2M Datasheet

Example 28-Pin QFN Land Pattern

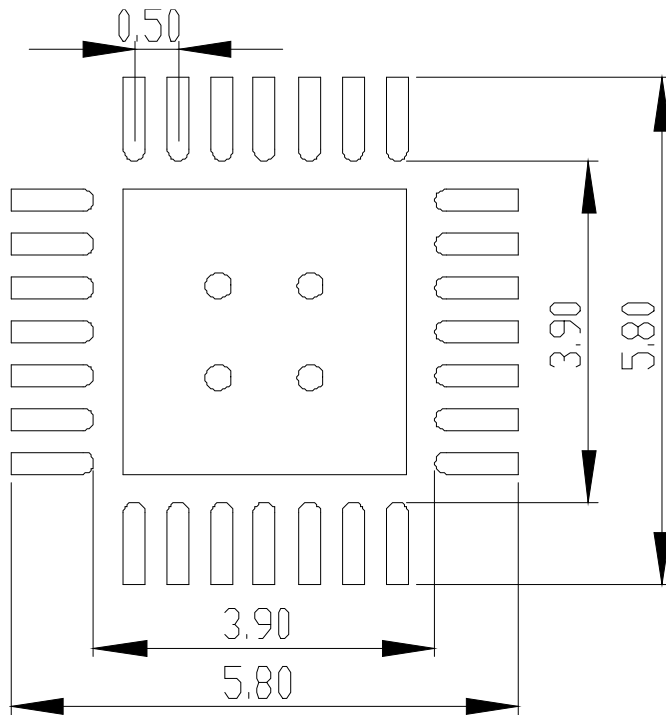

Non Solder Mask Defined Pad
All Around

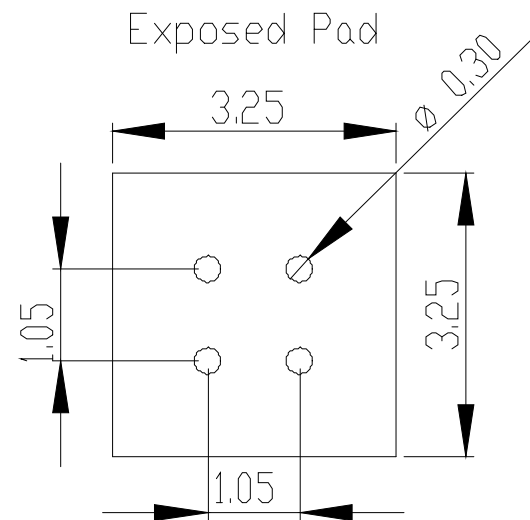
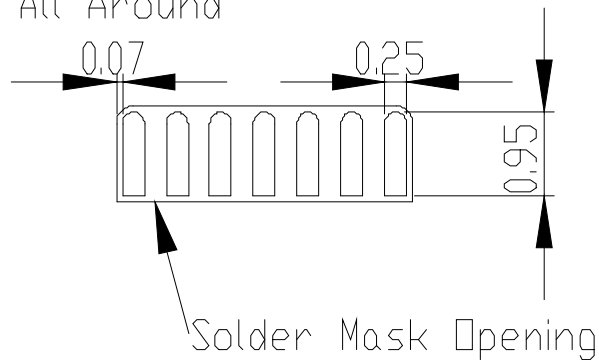

Notes:

1. All dimensions are in millimeters.
2. Thermal vias should be 0.3mm to 0.33mm in diameter, with the barrel plated to 1oz copper.
3. For maximum solder mask in the corners, round the inner corners of each row.
4. Exposed pad should be solder mask defined.
5. Pad width can be reduced to 0.25mm if additional pad to pad clearance is required.
6. For applications where solder loss through vias is a concern, plugging or tenting of the vias should be used. The solder mask diameter for each via should be 0.1mm larger than the via diameter.

New product version is available in ES9020Q

ES9016K2M Datasheet



Reflow Process Considerations

For lead-free soldering, the characterization and optimization of the reflow process is the most important factor you need to consider.

The lead-free alloy solder has a melting point of 217°C. This alloy requires a minimum reflow temperature of 235°C to ensure good wetting. The maximum reflow temperature is in the 245°C to 260°C range, depending on the package size (*Table RPC-2*). This narrows the process window for lead-free soldering to 10°C to 20°C.

The increase in peak reflow temperature in combination with the narrow process window makes the development of an optimal reflow profile a critical factor for ensuring a successful lead-free assembly process. The major factors contributing to the development of an optimal thermal profile are the size and weight of the assembly, the density of the components, the mix of large and small components, and the paste chemistry being used.

Reflow profiling needs to be performed by attaching calibrated thermocouples well adhered to the device as well as other critical locations on the board to ensure that all components are heated to temperatures above the minimum reflow temperatures and that smaller components do not exceed the maximum temperature limits (*Table RPC-2*).

To ensure that all packages can be successfully and reliably assembled, the reflow profiles studied and recommended by ESS are based on the JEDEC/IPC standard J-STD-020 revision D.1.

Figure RPC-1. IR/Convection Reflow Profile (IPC/JEDEC J-STD-020D.1)

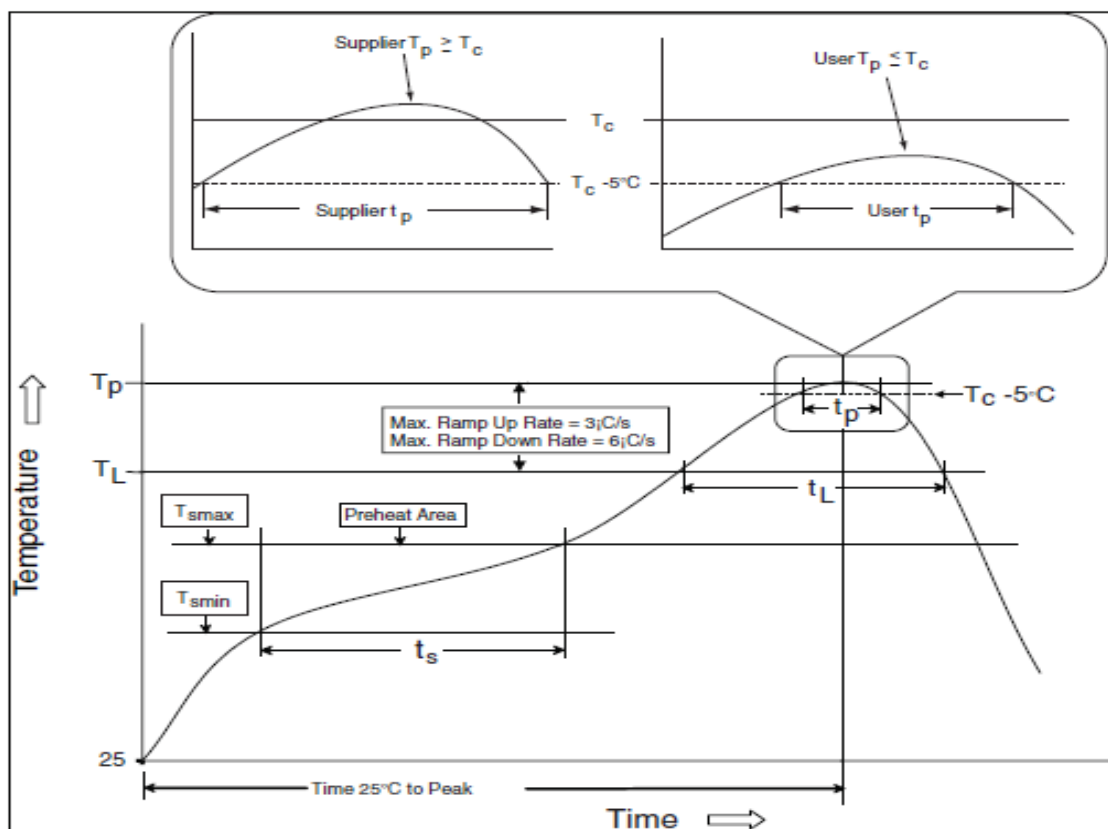

Note: Reflow is allowed 3 times. Caution must be taken to ensure time between re-flow runs does not exceed the allowed time by the moisture sensitivity label. If the time elapsed between the re-flows exceeds the moisture sensitivity time bake the board according to the moisture sensitivity label instructions.

Manual Soldering:

Allowed up to 2 times with maximum temperature of 350 degrees no longer than 3 seconds.



New product version is available in ES9020Q

ES9016K2M Datasheet

Table RPC-1 Classification reflow profile

Profile Feature	Pb-Free Assembly
Preheat/Soak	
Temperature Min (T _{min})	150°C
Temperature Max (T _{max})	200°C
Time (ts) from (T _{min} to T _{max})	60-120 seconds
Ramp-up rate (TL to Tp)	3°C / second max.
Liquidous temperature (TL)	217°C
Time (tL) maintained above TL	60-150 seconds
Peak package body temperature (Tp)	For users Tp must not exceed the classification temp in Table RPC-2. For suppliers Tp must equal or exceed the Classification temp in Table RPC-2.
Time (tp)* within 5°C of the specified classification temperature (Tc), see Figure RPC-1	30* seconds
Ramp-down rate (Tp to TL)	6°C / second max.
Time 25°C to peak temperature	8 minutes max.
* Tolerance for peak profile temperature (Tp) is defined as a supplier minimum and a user maximum.	

Note 1: All temperatures refer to the center of the package, measured on the package body surface that is facing up during assembly reflow (e.g., live-bug). If parts are reflowed in other than the normal live-bug assembly reflow orientation (i.e., dead-bug), Tp **shall** be within $\pm 2^\circ\text{C}$ of the live-bug Tp and still meet the Tc requirements, otherwise, the profile **shall** be adjusted to achieve the latter. To accurately measure actual peak package body temperatures refer to JEP140 for recommended thermocouple use.

Note 2: Reflow profiles in this document are for classification/preconditioning and are not meant to specify board assembly profiles. Actual board assembly profiles should be developed based on specific process needs and board designs and should not exceed the parameters in Table RPC-1. For example, if Tc is 260°C and time tp is 30 seconds, this means the following for the supplier and the user.
For a supplier: The peak temperature must be at least 260°C. The time above 255°C must be at least 30 seconds.
For a user: The peak temperature must not exceed 260°C. The time above 255°C must not exceed 30 seconds.

Note 3: All components in the test load **shall** meet the classification profile requirements.

Table RPC-2 Pb-Free Process – Classification Temperatures (Tc)

Package Thickness	Volume mm ³ , <350	Volume mm ³ , 350 to 2000	Volume mm ³ , >2000
<1.6 mm	260°C	260°C	260°C
1.6 mm – 2.5 mm	260°C	250°C	245°C
>2.5 mm	250°C	245°C	245°C

Note 1: At the discretion of the device manufacturer, but not the board assembler/user, the maximum peak package body temperature (Tp) can exceed the values specified in Table RPC-2. The use of a higher Tp does not change the classification temperature (Tc).

Note 2: Package volume excludes external terminals (e.g., balls, bumps, lands, leads) and/or non-integral heat sinks.

Note 3: The maximum component temperature reached during reflow depends on package thickness and volume. The use of convection reflow processes reduces the thermal gradients between packages. However, thermal gradients due to differences in thermal mass of SMD packages may still exist.

New product version is available in ES9020Q

ES9016K2M Datasheet



ORDERING INFORMATION

Part Number	Description	Package
ES9016K2M	Sabre ³² ® Ultra 32-bit Low Power Stereo Audio DAC	28-pin QFN

The letter K identifies the package type QFN.

Revision History

Rev.	Date	Notes
1.1	March 19, 2014	Update MCLK requirement
1.2	April 15, 2014	Update sync_mode requirement
1.3	May 28, 2014	Update DSD L/R pin assignment. Add THD compensation registers. Update mechanical drawing and add land pattern. Update migration notes
1.4	June 5, 2014	Added SABRE SOUND™ trademark
1.5	July 28, 2014	Updated ESS' FAX number. Added medical usage legal disclaimer
1.6	August 28, 2014	Added conditions when an external DVDD regulator is required
1.7	September 8, 2014	Corrected typo on Register#7 Bit [6:5], 3'dX changed to 2'dX. Identified Left and Right channels for Registers #15 and #16 respectively. Updated DAC output impedance from 781.25Ω to 806Ω
1.8	September 24, 2014	Added "8 bit, Read-Write Register, Default = 0x00" heading on Register #21. Corrected part number on revision marking diagram, page 3. Removed reference to Right Justified data format that is not supported
1.9	October 16, 2014	Added table to Register #65 description.
2.0	January 8, 2015	Added details on decoupling required for the DVDD core supply. Deleted old revision history from 0.1 to 0.91.
2.1	April 10, 2015	Added notes on the connection of reserved Bits in the device control registers. Added SABRE HiFi logo. Updated ESS' address and phone number.
2.2	June 10, 2015	Increased typical value of AVCC_L plus AVCC_R from 3mA to 8mA
2.3	December 2, 2016	Correct Recommended Operating Conditions table formatting.
2.4	January 24, 2017	Corrected THD compensation description and Recommended Operating Conditions table formatting.
2.5	January 31, 2017	Remove references to Revision W silicon, clarify I2C address description.
2.6	February 14, 2017	Added description for Registers #2, #3 and #9. Register #65 labeled as GPIO Status. Added register map. Adjusted page number references as needed.
2.7	November 14, 2018	Added Low Power Audio DAC description, removed Advanced Information
2.8	March 13, 2019	Removed ESR capacitor requirement for DVDD. Updated SABRE®, SABRE SOUND® and Sabre ³² ®
2.9	December 30, 2019	Corrected SDA setup time from SCL rising units from "μs" to "ns".
3.0	April 27, 2020	Updated analog performance
3.1	January 7, 2021	Updated I/V converter filter circuit
3.2	March 26, 2021	Updated Register #9 default value



New product version is available in ES9020Q

ES9016K2M Datasheet

ESS' ICs are not intended, authorized, or warranted for use as components in military applications, medical devices or life support systems. ESS assumes no liability whatsoever and disclaims any expressed, implied or statutory warranty for use of ESS IC's in such unsuitable applications.

No part of this publication may be reproduced, stored in a retrieval system, transmitted, or translated in any form or by any means, electronic, mechanical, manual, optical, or otherwise, without the prior written permission of ESS Technology, Inc. ESS Technology, Inc. makes no representations or warranties regarding the content of this document. All specifications are subject to change without prior notice. ESS Technology, Inc. assumes no responsibility for any errors contained herein. U.S. patents pending.

Mouser Electronics

Authorized Distributor

Click to View Pricing, Inventory, Delivery & Lifecycle Information:

[ESS Technology:](#)

[ES9016K2M](#)