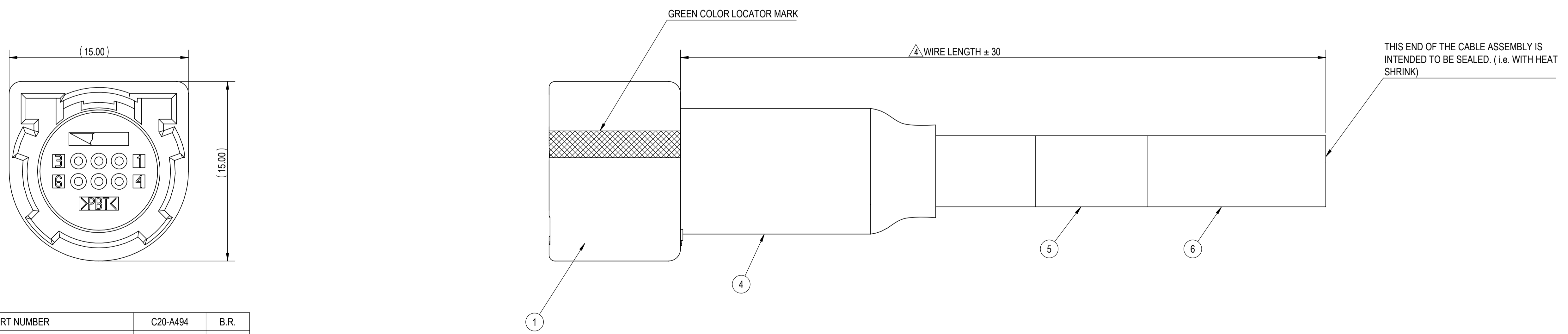

TABLE 3	CAVITY	WIRE SIZE	WIRE COLOR	INSULATION OD
1		22 AWG	BLACK	1.19±0.05
2		22 AWG	BLUE	1.19±0.05
3		22 AWG	RED	1.19±0.05
4		22 AWG	BARE	N/A
5	XX	22 AWG	WHITE	1.39±0.07
6		22 AWG	GREEN	1.39±0.07

TABLE 1	SUB-HARNESS PART NUMBER	NO.	PART NUMBER	PART NAME	COLOR	QUANTITY
7435-3747, ETC.		①	7289-0064	6P 0.64 SEALED FEMALE CAMERA CONNECTOR SUB-ASSEMBLY	NATURAL	1
		②	7129-5503	6P 0.64 SEALED FEMALE CAMERA CONNECTOR INNER HOUSING	NATURAL	1
		③	7115-2482-02	INNER TERMINAL FEMALE	-	6
		④	△ ES-2000 NO. 3 OR EQUIVALENT	HEAT SHRINK TUBE	BLACK	1
		⑤	N/A	ID LABEL	-	1
		⑥	AG59882	BELDEN VIDEO CABLE	BLACK	1

TABLE 2	PART NUMBER	PART NAME	WIRE LENGTH
	7435-3747	6P CAMERA CONNECTOR SUB-HARNESS	1500mm
	7435-3750	6P CAMERA CONNECTOR SUB-HARNESS	500mm
	7435-3751	6P CAMERA CONNECTOR SUB-HARNESS	3060mm
	7435-3752	6P CAMERA CONNECTOR SUB-HARNESS	5250mm
	7435-3754	6P CAMERA CONNECTOR SUB-HARNESS	6500mm
	△ 7435-3748	6P CAMERA CONNECTOR SUB-HARNESS	295mm
	△ 7435-3749	6P CAMERA CONNECTOR SUB-HARNESS	△ 2080mm
	△ 7435-3999	6P CAMERA CONNECTOR SUB-HARNESS	9244mm
	△ 7435-4766	6P CAMERA CONNECTOR SUB-HARNESS	320mm
	△ 7435-5406	6P CAMERA CONNECTOR SUB-HARNESS	6000mm
	△ 7435-5407	6P CAMERA CONNECTOR SUB-HARNESS	200mm
	△ 7435-5518	6P CAMERA CONNECTOR SUB-HARNESS	6900mm
	△ 7435-5519	6P CAMERA CONNECTOR SUB-HARNESS	4600mm
	△ 7435-6046	6P CAMERA CONNECTOR SUB-HARNESS	7500mm
	△ 7435-6106	6P CAMERA CONNECTOR SUB-HARNESS	6780mm
	△ 7435-6107	6P CAMERA CONNECTOR SUB-HARNESS	8360mm
	△ 7435-6730	6P CAMERA CONNECTOR SUB-HARNESS	5400mm
	△ 7435-7548	6P CAMERA CONNECTOR SUB-HARNESS	6515mm
	△ 7459-9179	6P CAMERA CONNECTOR SUB-HARNESS	602mm
	△ 7459-9585	6P CAMERA CONNECTOR SUB-HARNESS	6290mm
	△ 7459-6762	6P CAMERA CONNECTOR SUB-HARNESS	4345mm
	△ 7459-6763	6P CAMERA CONNECTOR SUB-HARNESS	7310mm
	△ 7375-3307	6P CAMERA CONNECTOR SUB-HARNESS	4485mm



LET	DATE	REVISION RECORD	NO.	CHKD
△ 11	07-22-2020	ADDED PART NUMBER	C20-A494	B.R.
△ 10	04-17-2019	ADDED PART NUMBERS	C19-A368	M.S.
△ 9	09-07-2017	ADDED PART NUMBER	C17-A920	E.H.
△ 8	06-01-2017	ADDED PART NUMBER	C17-A588	I.M.
△ 7	09-23-2015	ADDED PART NUMBER	C15-A580	R.B.
△ 6	03-13-2015	ADDED PART NUMBER	C15-A223	MT
△ 5	10-30-2014	ADDED PART NUMBERS	C14-A776	MT
△ 4	08-04-2014	ADDED PART NUMBERS	C14-A573	MT
△ 3	04-24-2014	MODIFIED WIRE LENGTH	C14-A307	IZ
△ 2	03-07-2014	REMOVED & ADDED PART NUMBERS	C14-A086	JM
△ 1	11-07-2013	ADDED PART NUMBER	C13-A605	VL
-	07-17-2013	NEW	C13-A425	MMR

NOTES:  
 1. PART TO COMPLY WITH YPES-31-038 REQUIREMENTS. THIS DRAWING IS TO BE USED FOR INTERNAL YAZAKI PSW SUBMISSION.  
 2. LABEL SHOWS PART NUMBER, REVISION LEVEL, AND MANUFACTURING DATE.

GENERAL TOLERANCE											
A	±0.15	±0.2	±0.3	±0.5	±0.75	R5 MAX	R10 MAX	R20 MAX	R20 OVR	ANGLE	ECCENT
B	±0.2	±0.3	±0.55	±0.95	±1.4	±0.2	±0.3	±0.5	±2.5	±3°	0.1
C	±0.3	±0.5	±0.8	±1.4	±2					±3°	0.15

CUSTOMER		CUSTOMER PART NO.		CUSTOMER DWG NO.		MTRL SPEC.		N/A		TREAT. & FIN.		N/A	
OFFICE		YNA		TRIAL PART NO.		NAME		6P CAMERA CONNECTOR SUB-HARNESS					
VENDOR		VENDOR NO.		DWG TYPE		DWG SOURCE		DS14RCAMAA / △		DWG DATE		07-17-2013	
APPROVED		CHECKED		CHECKED		DESIGN		DRAWN		PART NO.		7435-3747, ETC.	
						JUSTIN GERWATOWSKI		BENJAMIN RODRIGUEZ		DWG NO.		7435-3747:R	
						11-08-2011		07-28-2020		YAZAKI CORPORATION			

# Mouser Electronics

Authorized Distributor

Click to View Pricing, Inventory, Delivery & Lifecycle Information:

[Yazaki:](#)

[74353750](#) [74353754](#) [74353751](#) [74599179](#) [74353747](#) [74353748](#) [74356046](#)