

PCB FOOTPRINT

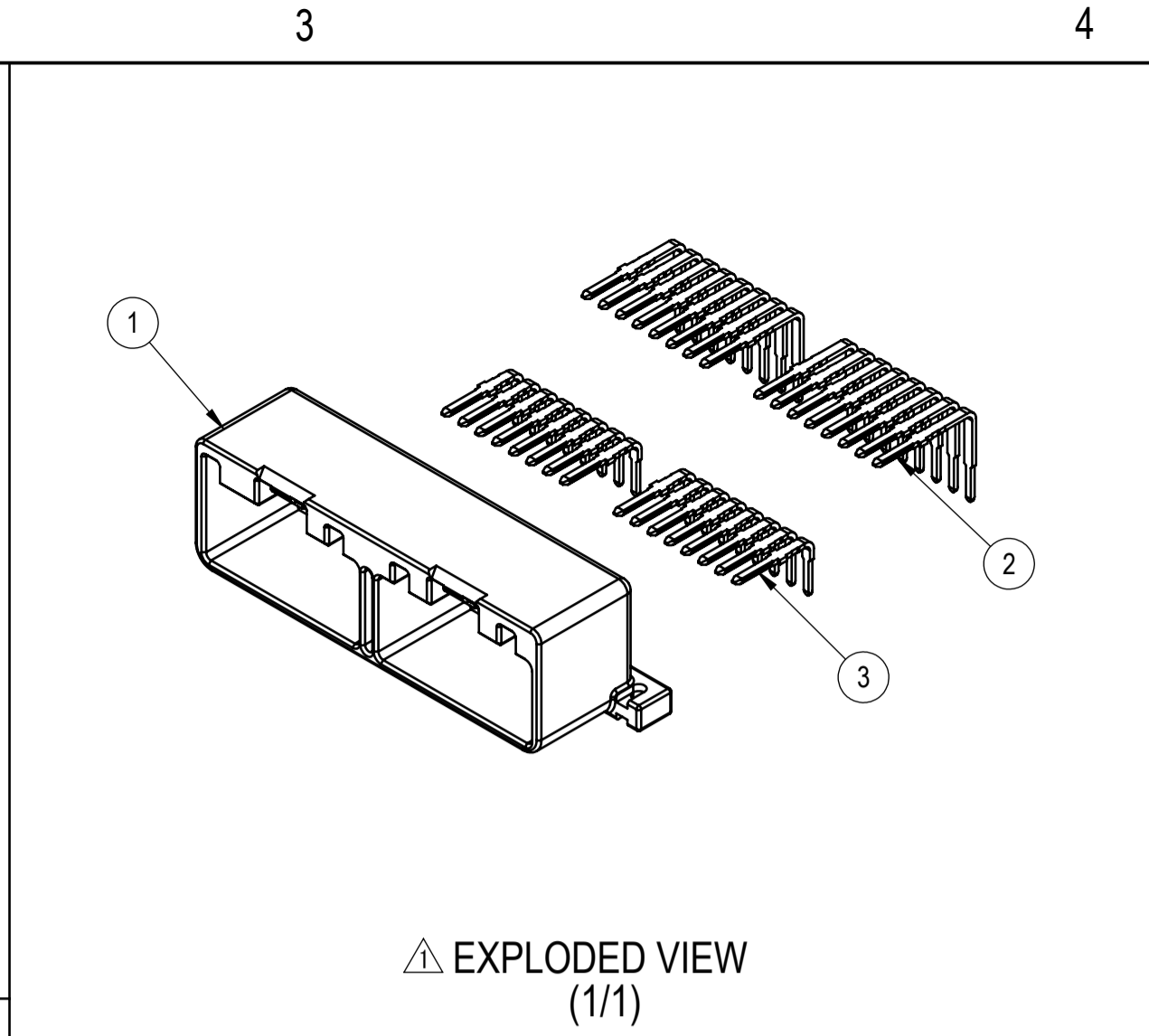

EXPLODED VIEW (1/1)

ASSEMBLY PART NUMBER	NO.	PART NUMBER	PART NAME	MATERIAL	COLOR	QUANTITY
7386-5687-3R	①	7186-5687-30	32P 1.5 MALE HEADER HOUSING	PPA-GF16	BLACK	1
	②	7114-4170-R2	1.5 PCB MALE TERMINAL LEAD-FREE	BRASS	-	16
	③	7114-4171-R2	1.5 PCB MALE TERMINAL LEAD-FREE	BRASS	-	16

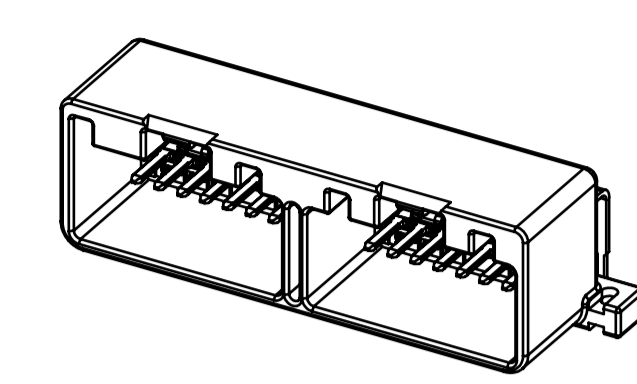

FRONT ISOMETRIC VIEW (1/1)

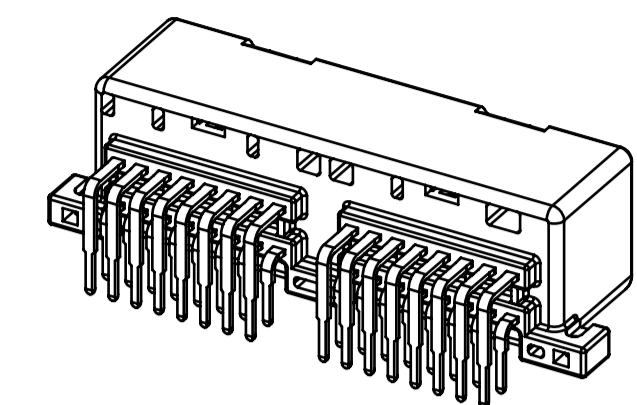

REAR ISOMETRIC VIEW (1/1)

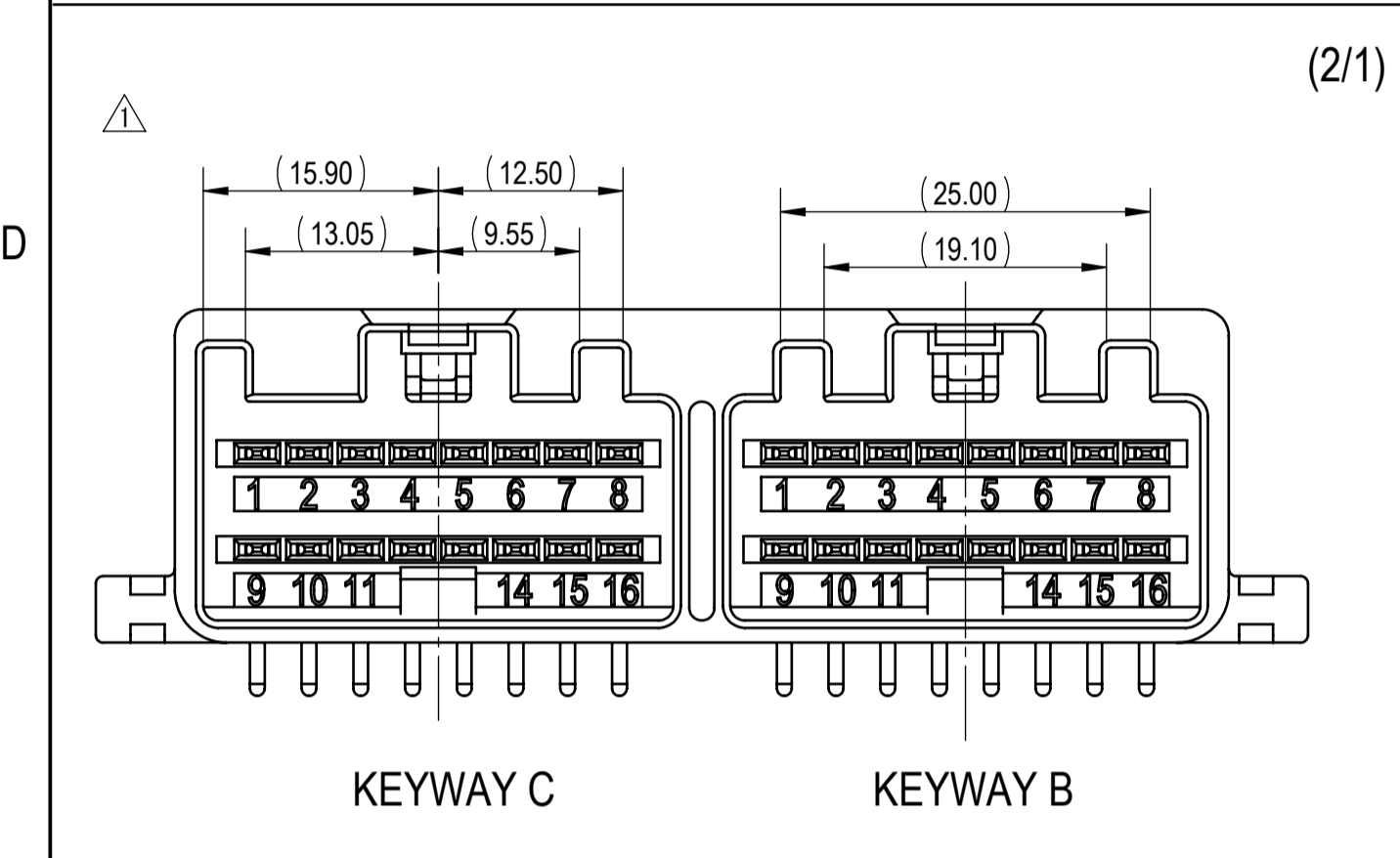

KEYWAY C KEYWAY B

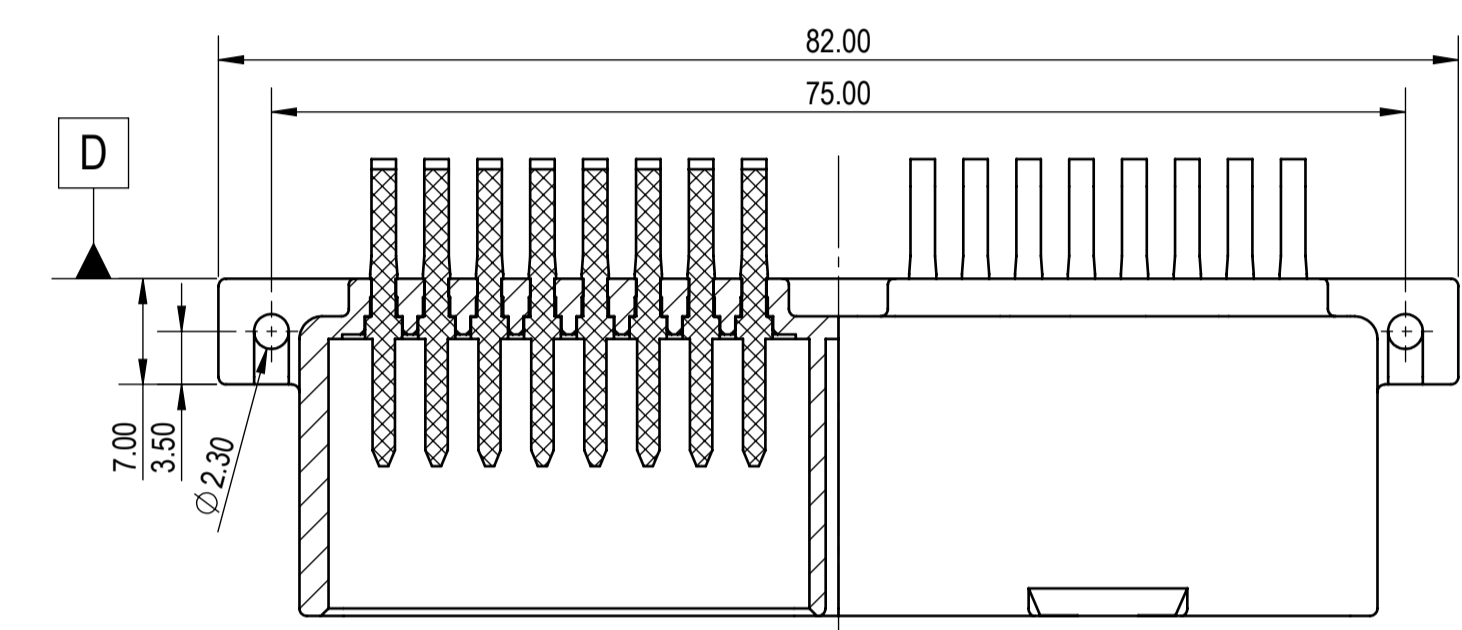

SECTION B-B

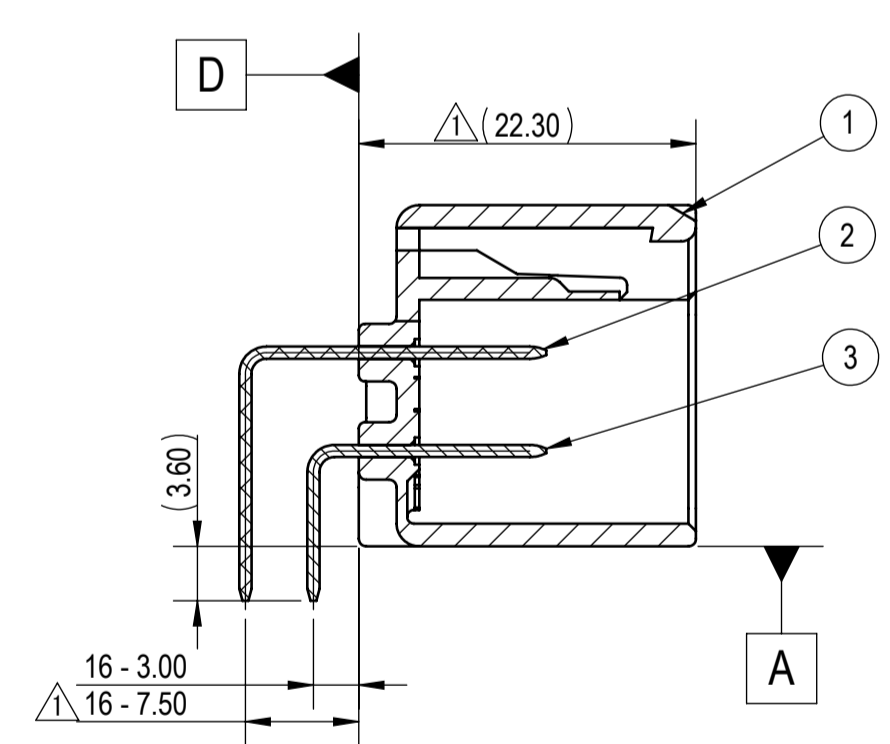
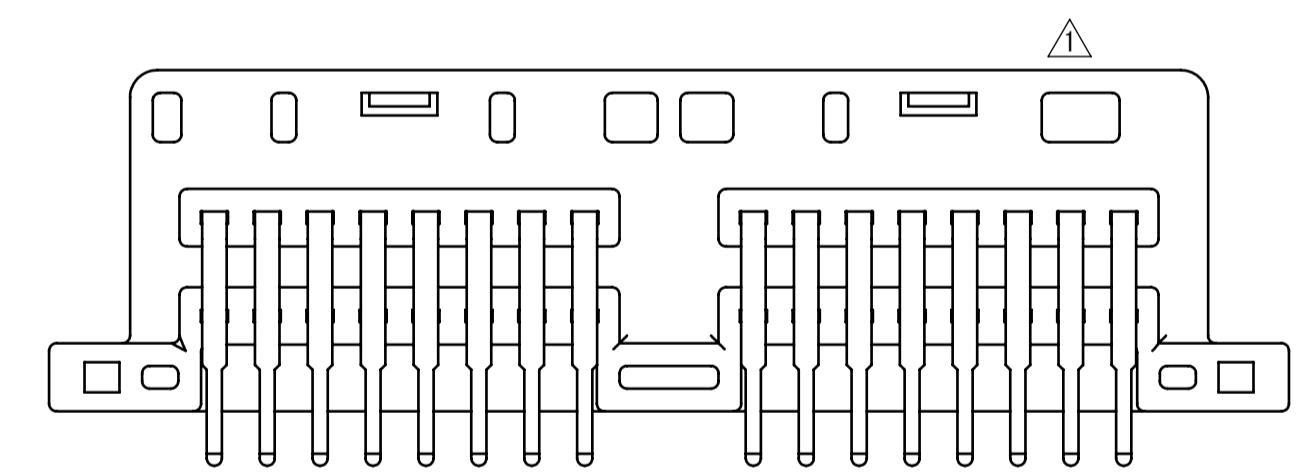

SECTION A-A

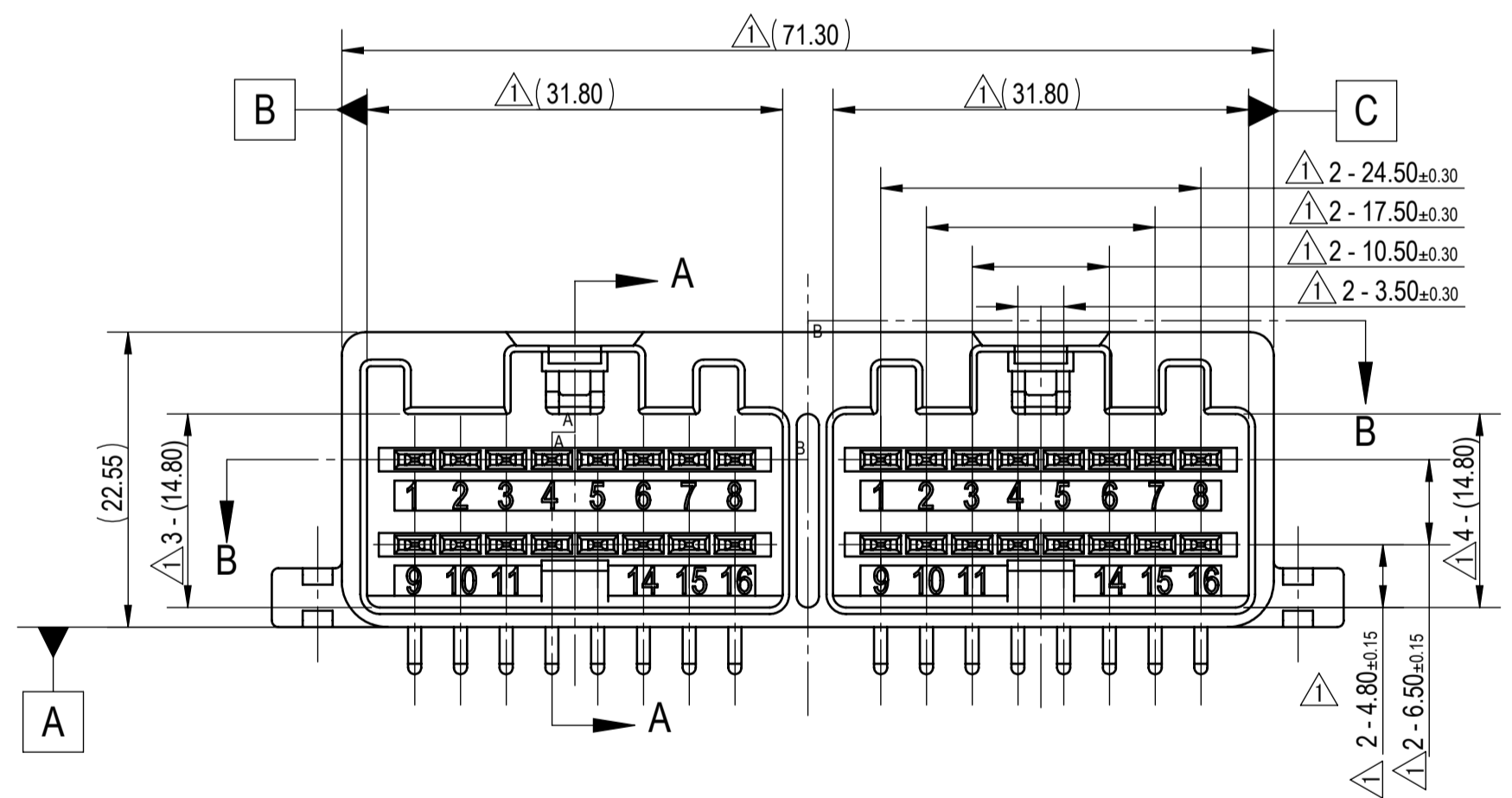

NOTES:

- PARTS MUST BE PURCHASED FROM YAZAKI.
- PARTS MUST BE FREE OF FLASH AND IMPERFECTIONS THAT AFFECT FUNCTION.
- MATING PART NUMBER: KEYWAY B: 7283-6456-90, 7283-6456-80
KEYWAY C: 7283-3585-40
- PART SATISFIES USCAR-2, REV. 6, FEB 2013, (T2V1/S1/MF3).
- PART TO COMPLY WITH YPES-31-038 REQUIREMENTS.
- THIS DRAWING IS TO BE USED FOR INTERNAL YAZAKI PSW SUBMISSION.
- AFTER BEING PRESSED IN, THE TERMINALS MUST BE FREE OF PLASTIC RESIN.
- TERMINALS MUST NOT BE LOOSE AFTER BEING INSERTED UNDER PRESSURE.
- RECOMMENDED FASTENING TAPPINGS SCREW PER JIS B1122 & B1007; M3X1.6 PANHEAD SECOND CLASS.
- RECOMMENDED TIGHTENING TORQUE FOR SCREW ASSEMBLY : 0.65Nm~0.80Nm

REV	DATE	REVISION RECORD	NO.	CHKD
△	01-30-2019	REVISED FORM, NOTES, DIMENSIONS, ADDED MASS, VIEWS & COLOR COLUMN	C19-A080	I.M.
-	02-26-2016	NEW	C16-A065	K.P.

GENERAL TOLERANCE									
	10MAX	50MAX	100MAX	250MAX	250OVR	R5 MAX	R10 MAX	R20 MAX	R20 OVR
A	±0.15	±0.20	±0.30	±0.50	±0.75				
B	±0.20	±0.30	±0.55	±0.95	±1.40	±0.20	±0.30	±0.50	±2.50
C	±0.30	±0.50	±0.80	±1.40	±2.00				
SPECIFIED									
ANGLE	±3°								
ECCENT	0.1								
MASS	△ (15.60) g								

CUSTOMER		CUSTOMER DWG NO.		MATL SPEC.	SEE TABLE	TREAT. & FIN.	N/A
OFFICE YNA		TRIAL PART NO.		NAME 32P 1.5mm MALE HEADER ASSEMBLY			
VENDOR		VENDOR NO.		LEAD-FREE COMPLIANT			
DWG TYPE R		DWG SOURCE 7386-5687-3R:M		DWG DATE 02-26-2016		UNIT mm	
APPROVED		CHECKED		DESIGN		DRAWN	
RYAN BARTLETT		ISABEL MUNIZ		10-30-2015		02-06-2019	
PART NO. 7386-5687-3R		CH. CODE		DWG NO. 7386-5687-3R-R			
YAZAKI CORPORATION							

Mouser Electronics

Authorized Distributor

Click to View Pricing, Inventory, Delivery & Lifecycle Information:

[Yazaki:](#)

[738656873R](#)