

ASSEMBLY PART NUMBER	NO.	PART NUMBER	PART NAME	MATERIAL	COLOR	QUANTITY
△ SEE TABLE 2	①	SEE TABLE 2	26P 0.64 TYCO GEN Y UNSEALED PCB MALE HEADER HOUSING (H)	PPA-GF16	SEE TABLE 2	1
	②	7173-0594	26P 0.64 TYCO GEN Y UNSEALED PCB MALE HEADER ALIGNMENT PLATE (H)	PPA-GF16	NATURAL	1
	③	7114-5776-02	0.64mm KAIZEN MALE PCB TERMINAL TYPE A	BRASS	N/A	13
	④	7114-5777-02	0.64mm KAIZEN MALE PCB TERMINAL TYPE B	BRASS	N/A	13

ASSEMBLY PART NUMBER	HOUSING PART NUMBER	KEYWAY	COLOR	YAZAKI MATING PART NUMBER	TRAY PACKAGING NUMBER
7386-2043-30	7186-2043-30	A	BLACK	7287-2043-30	CELL PACKED
△ 7397-1188-30	7186-2043-30	A	BLACK	7287-2043-30	TRYSTY003
7386-2044-40	7186-2044-40	B	LIGHT GRAY	7287-2044-40	
7386-2045-80	7186-2045-80	C	BROWN	7287-2045-80	
7386-2046-60	7186-2046-60	D	GREEN	7287-2046-60	

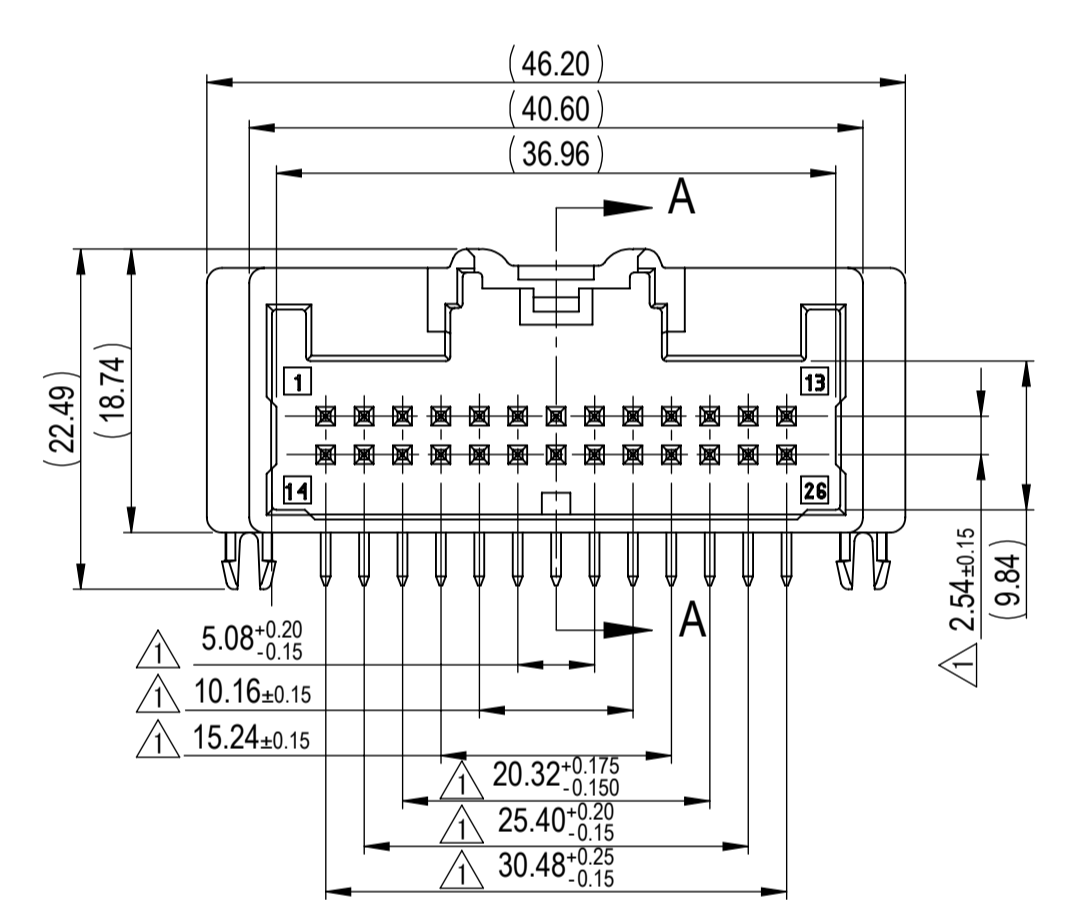
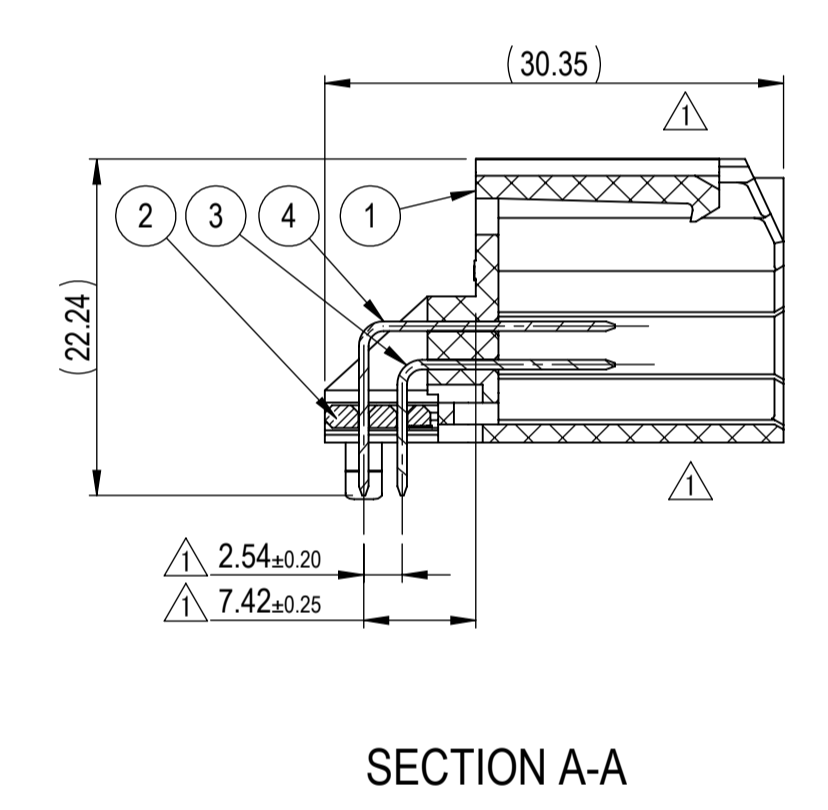
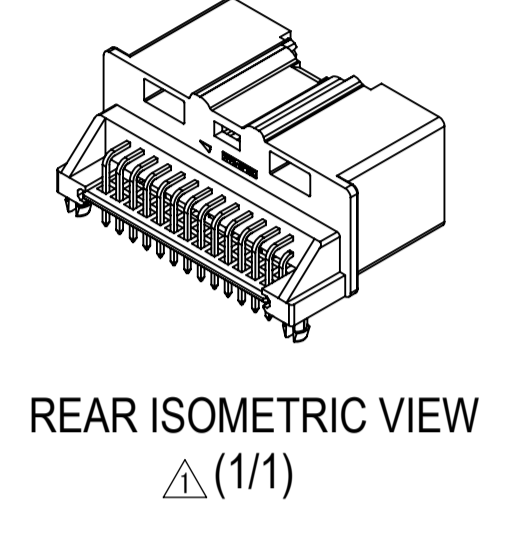
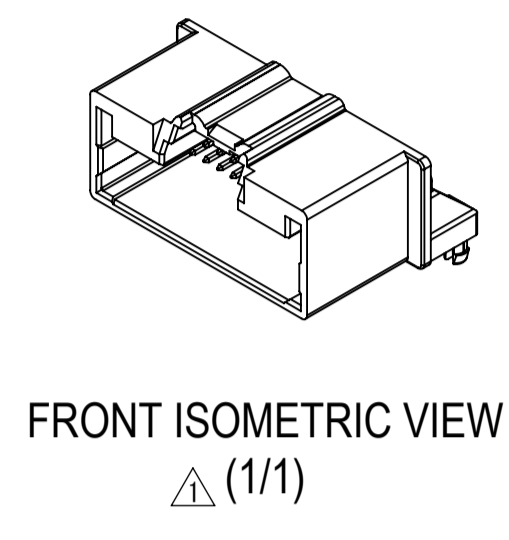

- △ NOTES:
- PARTS MUST BE PURCHASED FROM YAZAKI.
 - PARTS MUST BE FREE OF BURRS AND SHARP EDGES THAT MAY BE DETRIMENTAL TO SATISFACTORY ASSEMBLY, SAFE HANDLING OR FUNCTION OF THE PART.
 - PART SATISFIES USCAR-2, REV. 4, MAY 2004, (T2, V1, S1).
 - PART TO COMPLY WITH YPES-31-038 REQUIREMENTS.
 - RECOMMENDED OPTIONAL HOLE FOR SCREW MOUNTING FEATURE M2.3x5, HEAD ϕ 4.0
 - AFTER BEING PRESSED IN, THE TERMINALS MUST BE FREE OF PLASTIC RESIN.
 - THE TERMINALS MUST NOT BE LOOSE AFTER BEING INSERTED UNDER PRESSURE.
 - THIS DRAWING IS TO BE USED FOR INTERNAL YAZAKI PSW SUBMISSION.
 - ACCEPTABLE PCB THICKNESS RANGE = 1.30 TO 1.80mm

△	08-23-2018	ADDED TABLE 2, NEW PACKAGING OPTION AND NEW TOLERANCES, UPDATED NOTES, KEYWAY DIMENSIONS AND PART NUMBERS, AND DELETED DIMENSIONS	C18-A777	EH
-	07-06-2007	NEW	C07-A808	MMR
LET	DATE	REVISION RECORD	NO.	CHKD

GENERAL TOLERANCE										
	10MAX	50MAX	100MAX	250MAX	250OVR	R5 MAX	R10 MAX	R20 MAX	R20 OVR	ANGLE
A	±0.15	±0.2	±0.3	±0.5	±0.75					±3°
B	±0.2	±0.3	±0.55	±0.95	±1.4	±0.2	±0.3	±0.5	±2.5	±3°
(C)	±0.3	±0.5	±0.8	±1.4	±2					±3°
SPECIFIED										MASS (11.0)g

CUSTOMER PART NO.		CUSTOMER DWG NO.		MTRL SPEC. SEE TABLE		TREAT. & FIN.	
OFFICE YNA		TRIAL PART NO.		NAME 26P 0.64 TYCO GEN Y UNSEALED MALE			
VENDOR				PCB HORIZONTAL HEADER ASSEMBLY			
VENDOR NO.				PART NO. 7386-2043-30, ETC.		CH. CODE	
DWG TYPE R		DWG SOURCE 7386-2043-30-M		DWG DATE 07-06-2007		UNIT mm	
APPROVED		CHECKED		CHECKED		DESIGN DRAWN	
				K. LAZAR			
				04-05-2007			
				YAZAKI CORPORATION			
				SET DWG NO.			

ISSUE MARK

Mouser Electronics

Authorized Distributor

Click to View Pricing, Inventory, Delivery & Lifecycle Information:

[Yazaki:](#)

[7386204440](#) [7386204330](#) [7386204580](#)