

PART NUMBER	PART NAME	MATERIAL	COLOR	QUANTITY
7174-1784-30	5P 1.2mm SEALED FEMALE CONNECTOR WIRE SHIELD	PA66 - GF35	BLACK	1

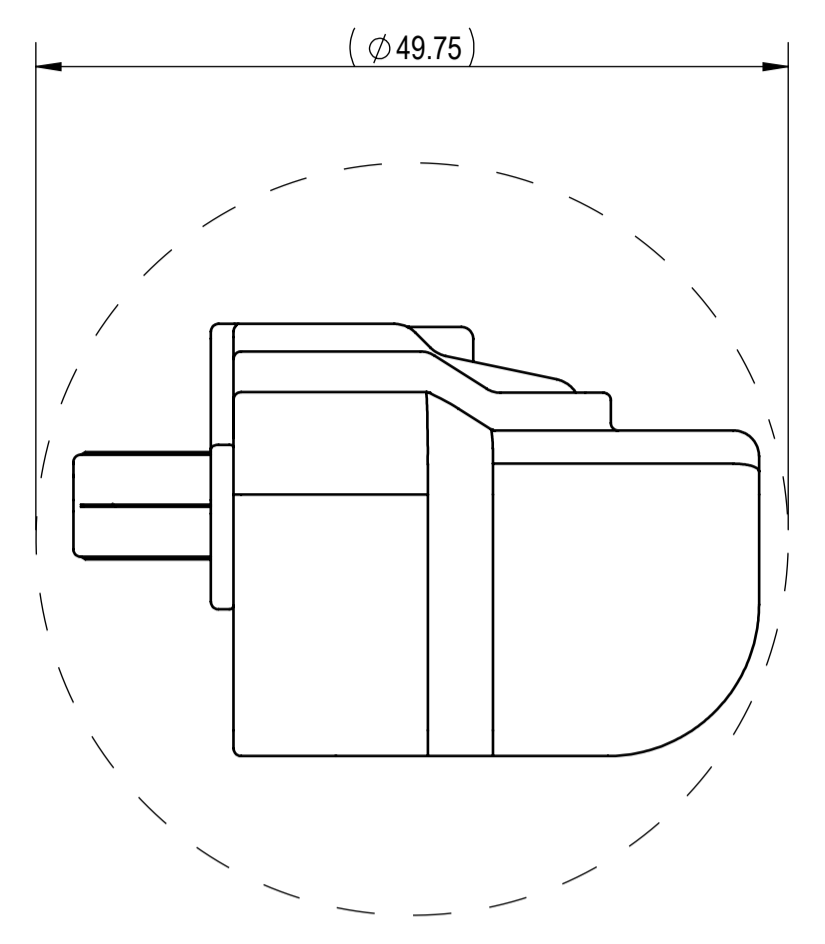

RECOMMENDED PASS-THROUGH HOLE DIMENSION
(1mm CLEARANCE ALL AROUND)
(2/1)

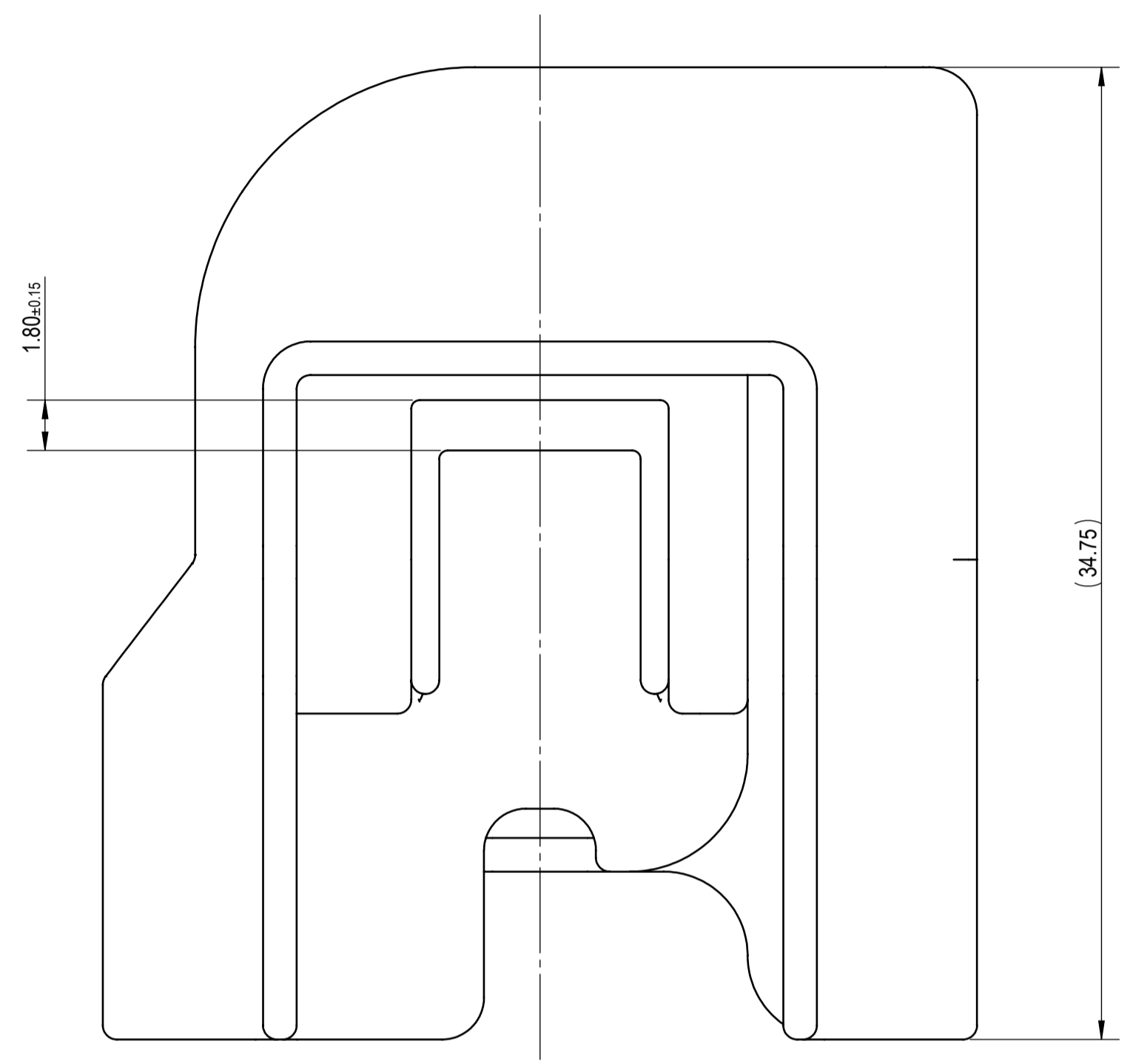
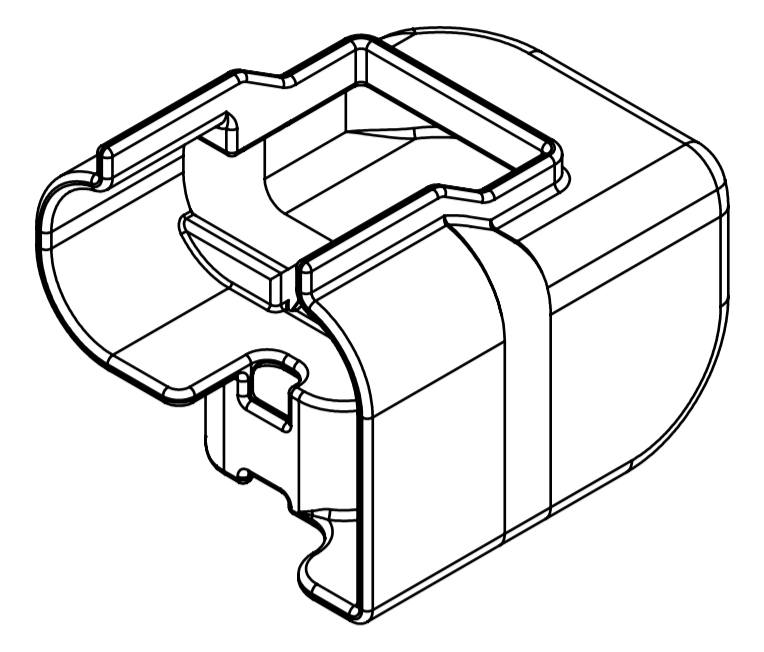

FRONT ISOMETRIC VIEW
(2/1)

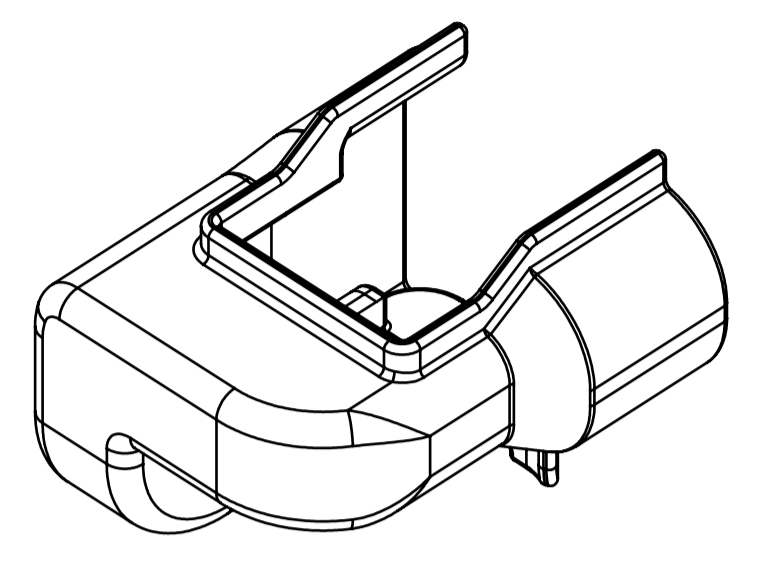

REAR ISOMETRIC VIEW
(2/1)

NOTES:

- PARTS MUST BE PURCHASED FROM YAZAKI.
- PARTS MUST BE FREE OF FLASH AND IMPERFECTIONS THAT AFFECT FUNCTION.
- APPLICABLE SUB-ASSEMBLY: 7289-4601-30, ETC.
- PART SATISFIES USCAR-2, REV. 6, FEB 2013 FOR MISCELLANEOUS COMPONENT ENGAGE/DISENGAGE FORCE.
- PART TO COMPLY WITH YPES-31-038 REQUIREMENTS.
- THIS DRAWING IS TO BE USED FOR INTERNAL YAZAKI PSW SUBMISSION.
- HANDLING MANUAL NUMBER: YPES-15-1666E.

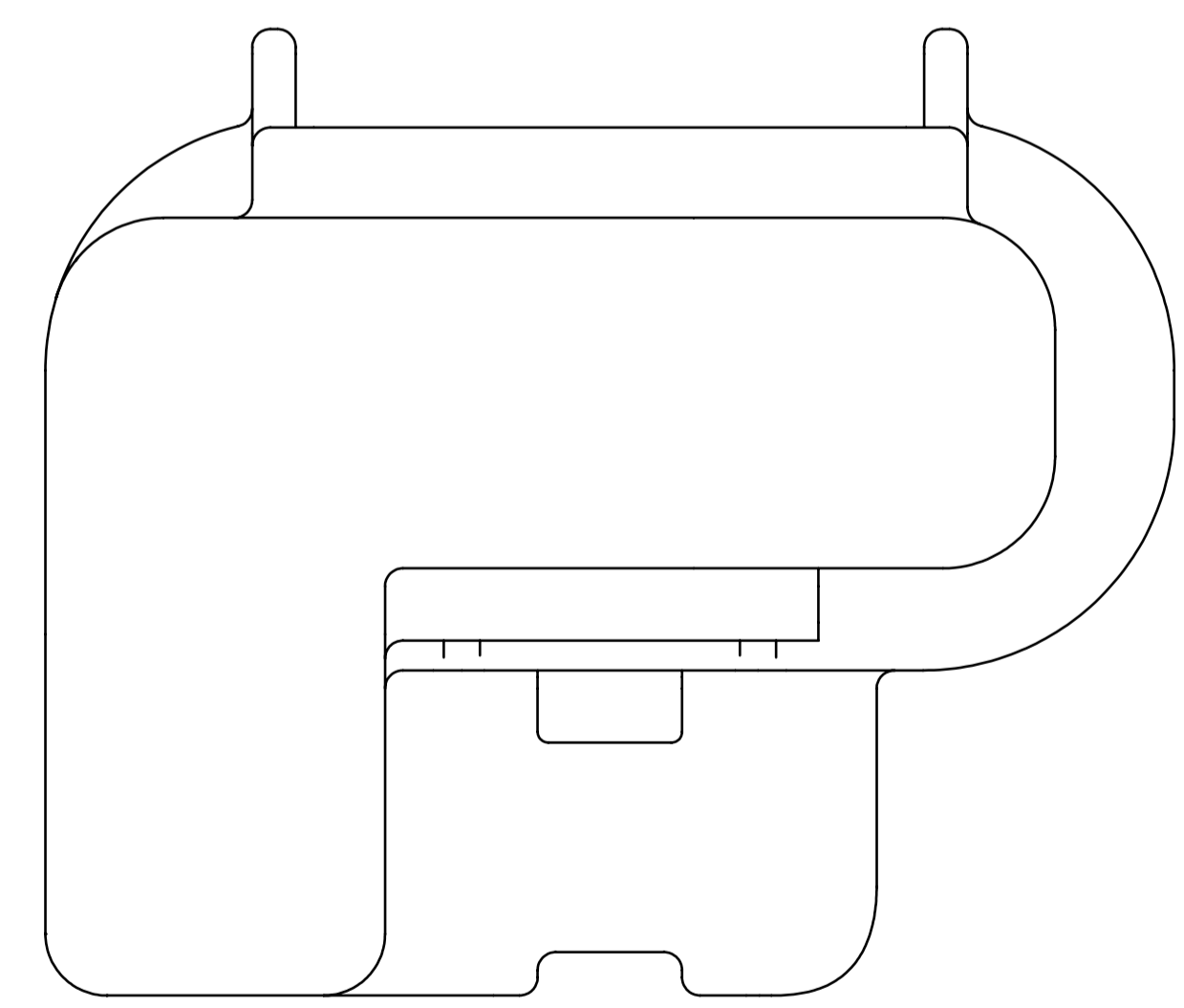
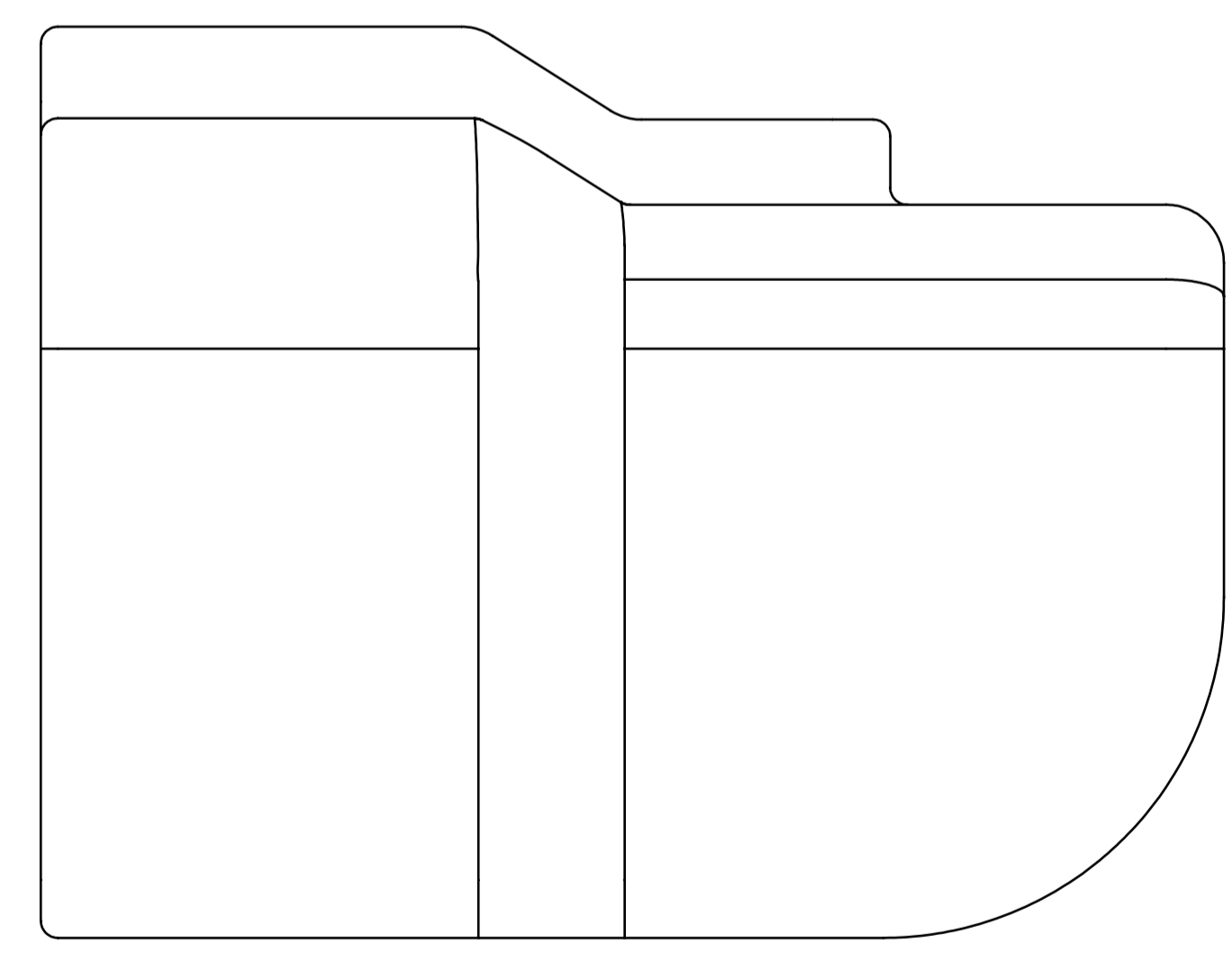
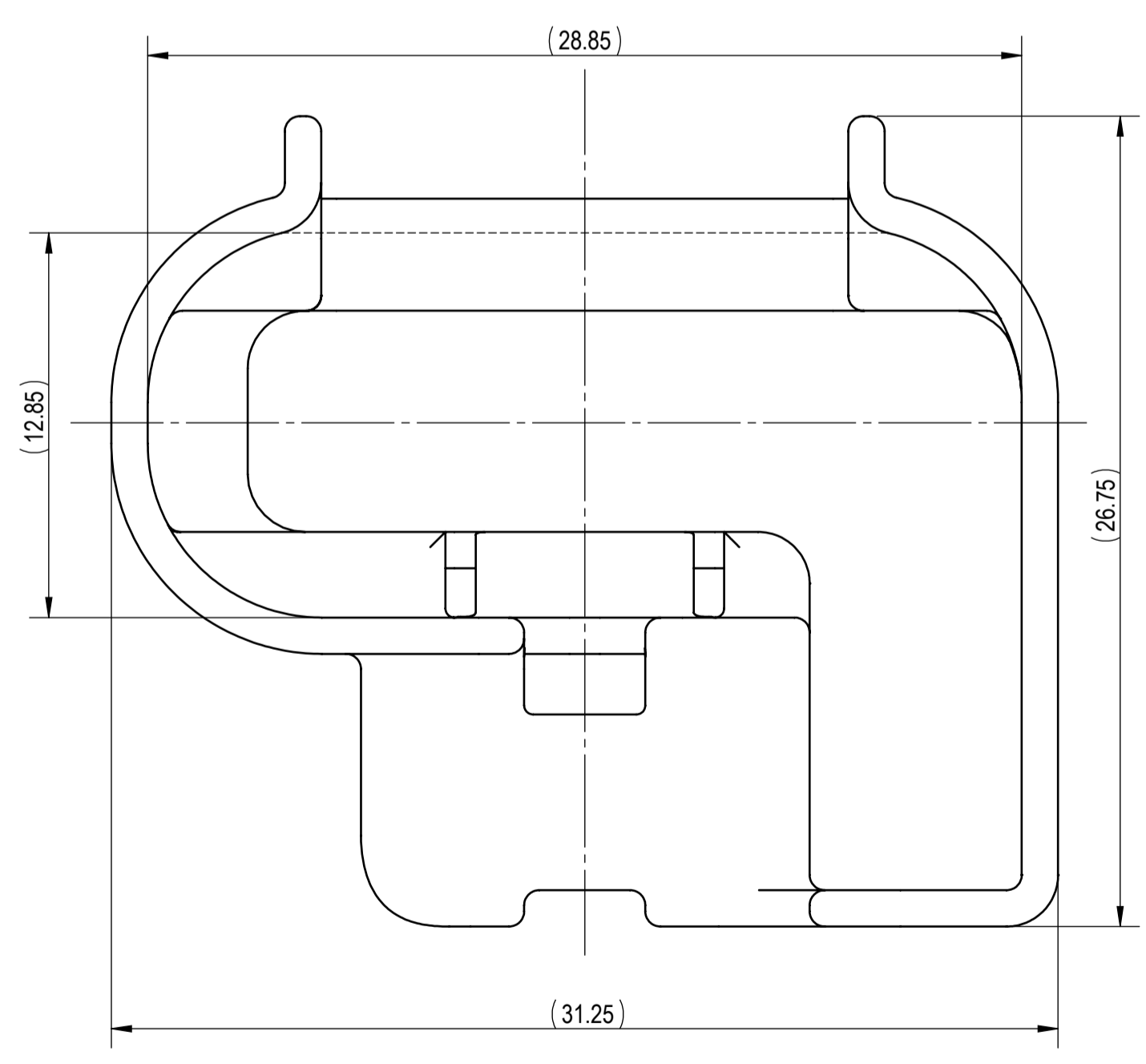

ISSUE MARK

LET	DATE	REVISION RECORD	NO.	CHKD
-	02-14-2018	NEW	C18-A124	SA

GENERAL TOLERANCE											
	10MAX	50MAX	100MAX	250MAX	250OVR	R5 MAX	R10 MAX	R20 MAX	R20 OVR	ANGLE	ECCENT
A	±0.15	±0.20	±0.30	±0.50	±0.75					±3°	0.1
B	±0.20	±0.30	±0.55	±0.95	±1.40	±0.20	±0.30	±0.50	±2.50	±3°	0.15
Ⓒ	±0.30	±0.50	±0.80	±1.40	±2.00					±3°	0.15
	SPECIFIED										MASS (5.36)g

CUSTOMER		CUSTOMER DWG. NO.		MTRL SPEC.		TREAT. & FIN.	
CUSTOMER PART NO.		CUSTOMER DWG. NO.		SEE TABLE		N/A	
OFFICE YNA		TRIAL PART NO.		NAME			
VENDOR		VENDOR NO.		5P 1.2mm SEALED FEMALE CONNECTOR WIRE SHIELD			
DWG TYPE		DWG SOURCE		DWG DATE		UNIT	
R		7174-1784-30:M		02-14-2018		mm	
APPROVED		CHECKED		DESIGN		DRAWN	
M. SHANTZ		SAUL AMPARAN		05-22-2017		02-19-2018	
PART NO.		CH. CODE		PART NO.			
7174-1784-30				7174-1784-30			
DWG NO.				DWG NO.			
7174-1784-30:R				7174-1784-30:R			
YAZAKI CORPORATION							

Mouser Electronics

Authorized Distributor

Click to View Pricing, Inventory, Delivery & Lifecycle Information:

[Yazaki:](#)

[7174178430](#)