

THIS DRAWING AND/OR ELECTRONIC FILE, AND THE DESIGN HEREON, CONSTITUTES A PROPRIETARY DESIGN OF DELPHI PACKARD ELECTRIC SYSTEMS, AND IS NOT TO BE DUPLICATED OR REPRODUCED EXCEPT TO PRODUCE GOODS AND SERVICES TO DELPHI AUTOMOTIVE SYSTEMS.

DO NOT SCALE

DELPHI PACKARD ELECTRIC SYSTEMS
WARREN, OHIO 44486

PART NO
1214 6916

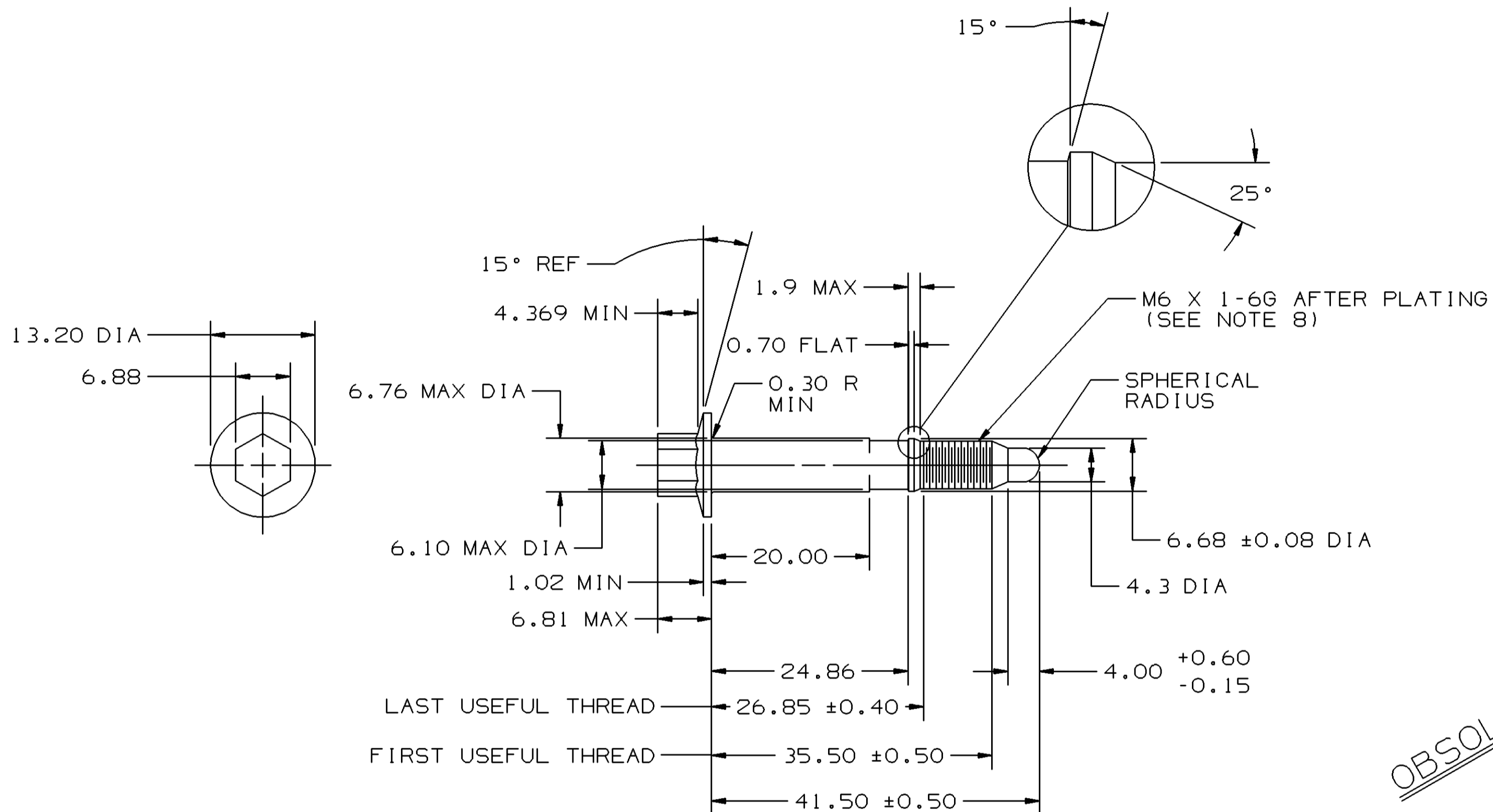

NOTES:

- DIMENSIONS ARE TO FACE OF VIEW SHOWN AND AUTOMATICALLY ROUNDED BY COMPUTER FOR INSPECTION. (SEE MATH MODEL FOR PRECISE DIMENSION) FOR ALL OTHER DIMENSIONS NOT SHOWN BUT REQUIRED FOR TOOL BUILD, SEE MATH MODEL FOR PRECISE TOOL PATH DATA.
- HARDNESS TO BE ROCKWELL B 85-105. (TO BE CHECKED ON THREADED END)
- ZINC/NICKEL PLATE PER GM 6280-M (Zn-Ni ACID) 0.0003" THICK (YELLOW CHROMATE).
- PART MUST BE FREE OF RUST AND OILY GRIT.
- USE M4 HEX-HEAD DRIVE SOCKET.
- BOLT MUST WITHSTAND 100 IN-LB OR 11.3 N-M THREAD STRIP TORQUE.
- THIS PART IS NOT CONTROLLED FOR AUTOMATIC FEEDING.
- THREADING ON BOLT SHOULD BE EQUIVALENT TO M6 X 1-6G DIMENSIONS AFTER PLATING AS DESCRIBED IN ANSI SPECIFICATION B1.13M.

OBSOLETE

DATE	SYM	REVISION RECORD	AUTH	DR	CK
06N092	A	PE DRAWING CREATION	920012	JR	
25MR93	B	DIM 35.50±0.50 WAS 36.50±0.50			TM
10JA94	B1	WAS PEO39658 & RELEASED	940005	TW	TW
23FE94	C	REVISED BOLT SHOULDER	159691	SM	SM
17MR94	D	REVISED BOLT SHOULDER; ADDED CODE NO. & QC	159870	JET	JET
28JL94	E	ADDED SPHERICAL RADIUS	161763	FKV	SMP
30MY97	E1	REVISED NOTE #3	180368	DEH	DEH
030C97	E2	4.00 +0.60/-0.15 WAS 4.00 & REVISED NOTE #1	181915	SLA	RRS
19AP99	E3	REVISED BOLT THREAD CALLOUT & ADDED NOTE #8	194006	TLP	TLP
240C05	E4	OBSOLETE	273824	JTZ	JAA

PART NO
1214 6916

DRAWING TYPE DETAIL		OTHER DRAWINGS AVAILABLE	
		METRIC DIMENSIONS ARE IN MILLIMETERS UNLESS OTHERWISE SPECIFIED	
THIRD ANGLE PROJECTION		TOLERANCE UNLESS OTHERWISE SPECIFIED DECIMAL: ANGULAR ± 2°	
		ONE PLACE ± 0.3	
CODE NO 6901	QC -R-301	TWO PLACE ± 0.15	
DWG DATE 06N092		DES	
SCALE 2:1		DR THAD WESTON 10JA94	
REFERENCE NO		CK THAD WESTON 10JA94	
		APPRJ.R CUNNINGHAM 19JA94	
		VOL CM ³	
MATERIAL SPEC GM 260M (1018-1022) STEEL			
NAME BOLT HEX HD FLG			
PART NUMBER 1214 6916			SIZE A2

Mouser Electronics

Authorized Distributor

Click to View Pricing, Inventory, Delivery & Lifecycle Information:

[Aptiv:](#)

[12146916](#)