

NOTES

- ON MAIN VIEW ASSEMBLY 33254285 SHOWN (CODE A)
- DELIVERED CONDITION AS ON MAIN VIEWS - SECONDARY LOCK IN OPEN POSITION
- ASSEMBLY INSTRUCTION NO.:
35269105-CUS71 - PRELIMINARY ASSEMBLY
35269105-CUS72 - HARNESS ASSEMBLY
35269102-CUS73 - CAR ASSEMBLY
- MATING PARTS:
- 3 WAY 1.5 FEMALE CONNECTOR ASM DWG-NO.: 33253566
- 2 WAY 1.5 FEMALE CONNECTOR ASM DWG-NO.: 35124386
- FIXING SLIDE APTIV DWG-NO.: 33329557 (HT DWG-NO.: 17-1455-001-CSG)
- BACKSHELL 90 DEG APTIV DWG-NO.: 33365444 (HT DWG-NO.: 17-2274-001-CSG)
- BACKSHELL 180 DEG APTIV DWG-NO.: 33365244 (HT DWG-NO.: 17-1454-001-CSG)
- ROTARY BACKSHELL 90 DEG APTIV DWG-NO.: 35024558 (HT DWG-NO.: 18-0195-001-CSG) ①
- ROTARY BACKSHELL 180 DEG APTIV DWG-NO.: 35024559 (HT DWG-NO.: 17-0598-001-CSG) ①
- PROTECTION CAP APTIV DWG-NO.: 35426243 (HT DWG-NO.: 17-2269-001-CSG)
- MATING TERMINAL SYSTEM:
- 1.5 TERMINAL DWG-NO.: 15396739
MAX WIRE CROSS SECTION: 1.0MM²
RECOMMENDATION FOR 1.5 TERMINAL WITH WIRE CROSS SECTION 1.5MM² - USE COMBINATION:
TE TERMINAL: TAB 1.6, DWG NO.: 1703278-5
SEAL: 2112323-1
MAX INSULATION CRIMP DIMENSIONS:
HEIGHT: 3.40; WIDTH: 3.40 ①

POSITION	1												2		3		4	
	HOUSING PANEL MOUNT												SECONDARY LOCK		SL SEAL	FIXING SEAL		
NAME																		
MATERIAL	PBT GF30 FR17				PBT GF30				PBT GF30 FR17	PBT GF30	LSR 50 SHORE	LSR 70 SHORE						
COLOR:	BLACK	GRAY	GREEN	BLUE	BLACK	GRAY	GREEN	BLUE	ORANGE	YELLOW	REDDISH-BROWN	REDDISH-BROWN						
PART-NO.:	33248987	33248992	33248999	33249006	33344614	33344620	33344621	33344623	33249026	33344606	33248990	33248985						

DWG STATUS				ZONE	REVISION HISTORY				AUTH	DR	APVD 1	APVD 2
DATE	STG	REV	N/P		CHG	INITIAL RELEASE						
250C18	R	01	AA	G11 E10	REFERENCE HELLERMANN TYTON DWG-NO. ADDED REFERENCE HELLERMANN TYTON PART-NO. ADDED					K.FAR	P.NAJ	M.GRU
280C20	R	01	AB	G10 G10 F10 G10	PROTECTION CAP APTIV DWG-NO.: 35426243 WAS 35274873 PART AVAILABILITY FOR PART NUMBERS 33344669, 33344671, 33344672, 33344827 NOTES UPDATED HT DWG-NO: 18-0195-001-CSG WAS 17-0195-001-CSG					P.NAJ	M.GRU	

NOTES

- 1 APTIV LOGO
- 2 MATERIAL NAME ACCORDING TO VDA 260
- 3 DATE INSERT
- 4 PART CAVITY NUMBER
- 5 MOVING DISTANCE OF SECONDARY LOCK

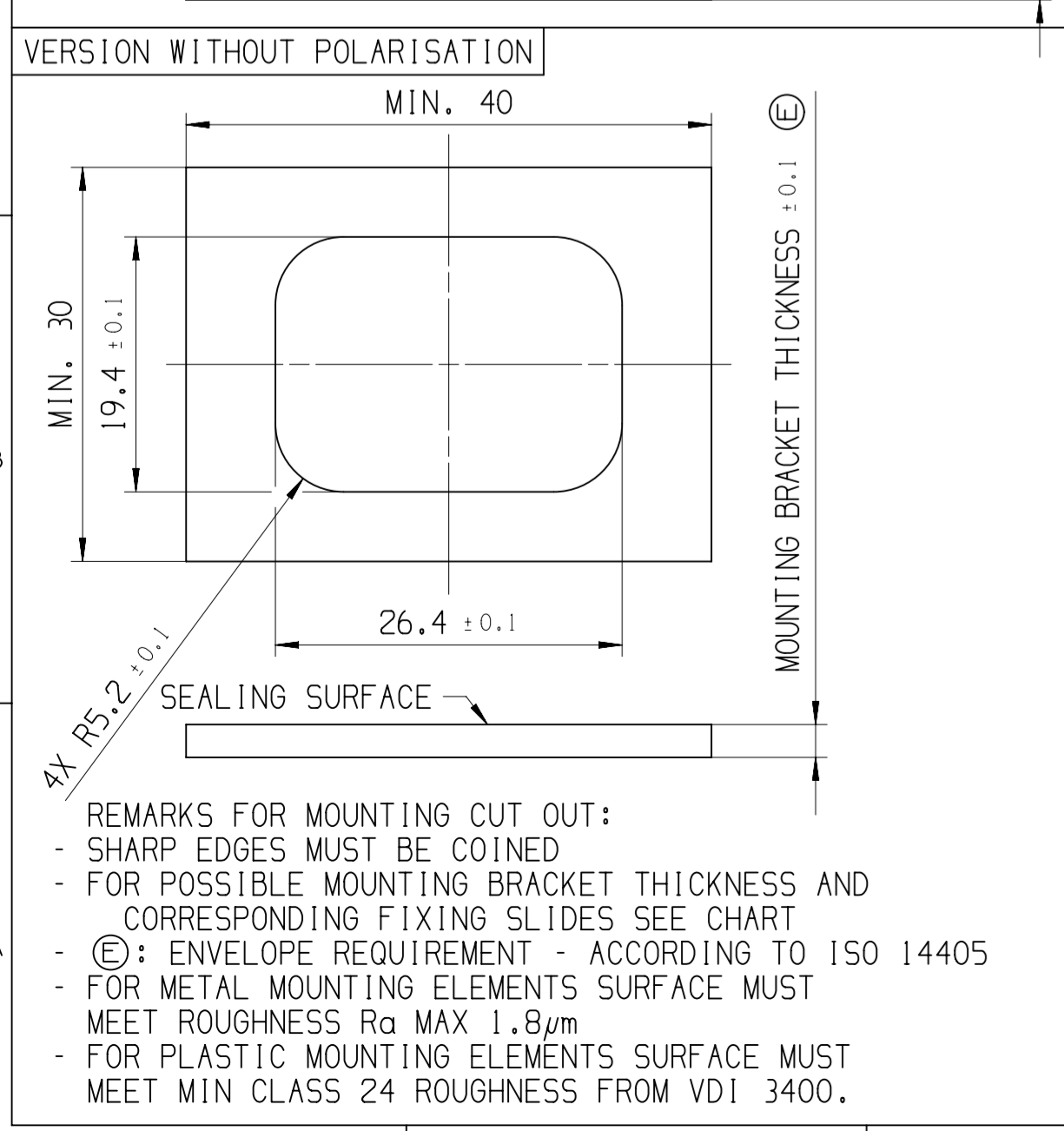
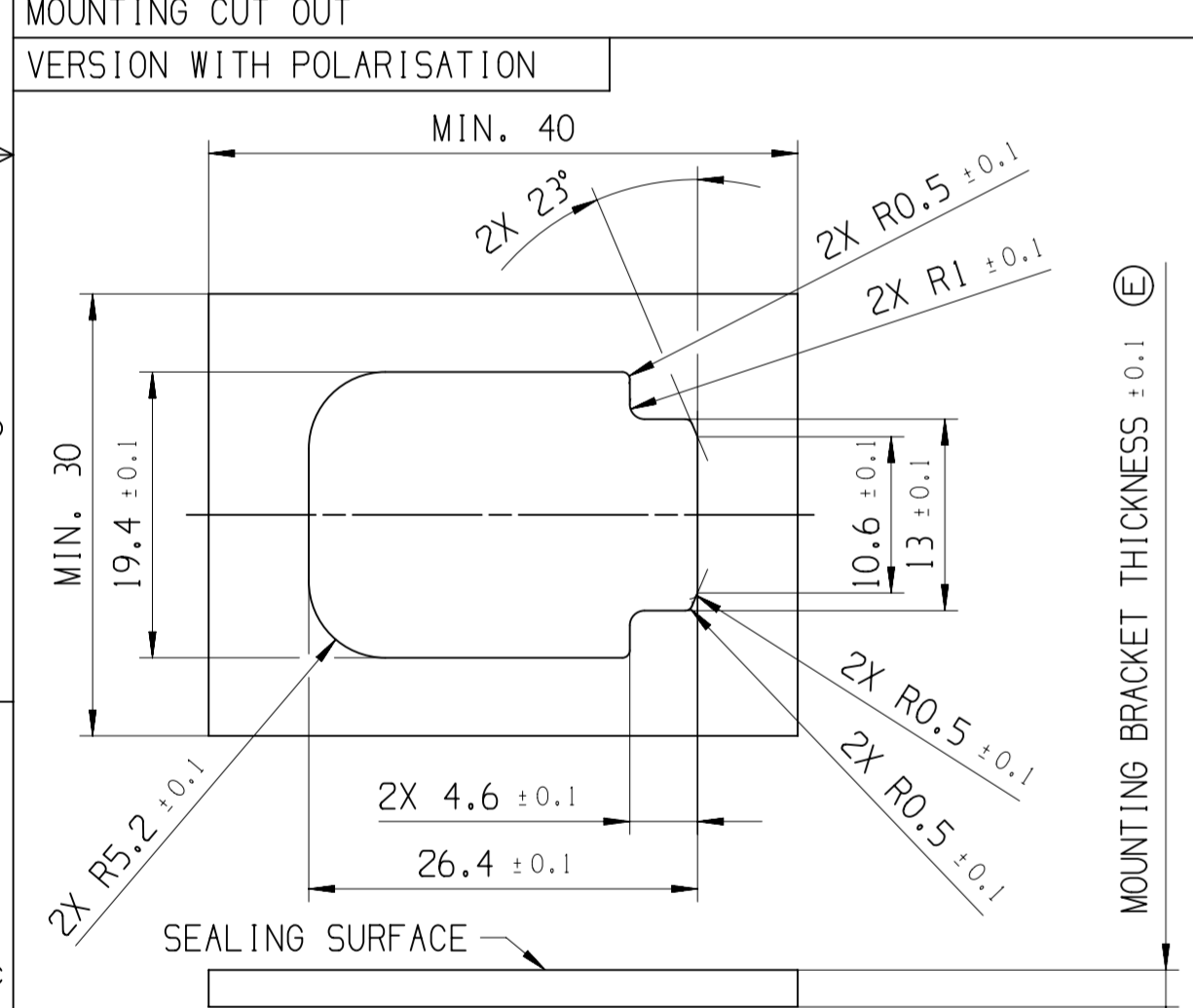
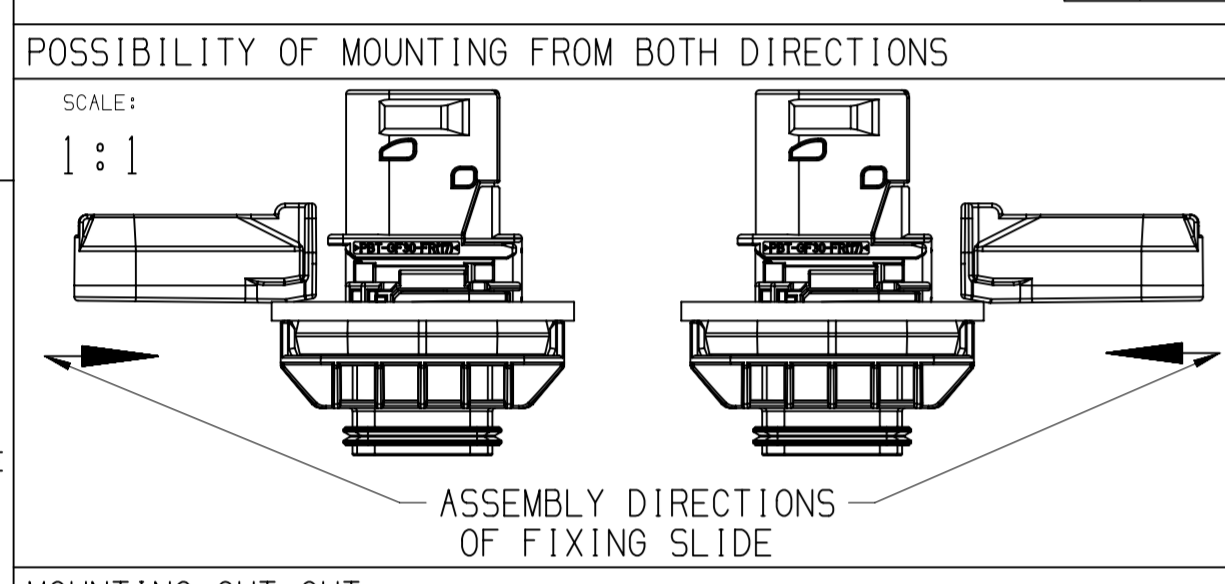

①

SHEET METAL THICKNESS	FIXING SLIDE APTIV/HT PART-NO.:	PBT GF30	COLOR
1MM	33366529	33366527	NATURAL
1.5MM	33366530	33366521	GRAY
2MM	33366531	33366520	BLUE
2.5MM	33329558 / 151-02344	33344019 / 151-02345	RED
3MM	33329560 / 151-02348	33344602 / 151-02349	YELLOW
3.5MM	33329561 / 151-02352	33344600 / 151-02353	GRAY
4MM	33366534	33366276	GREEN

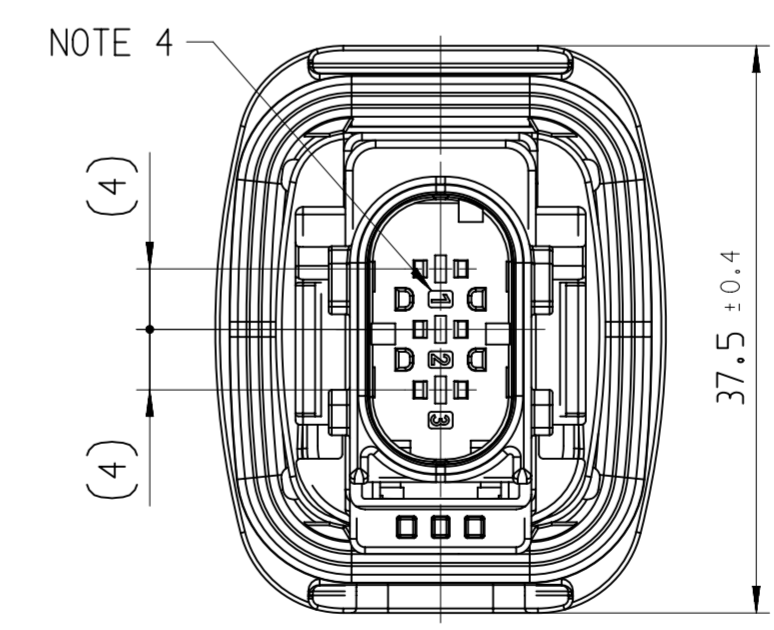
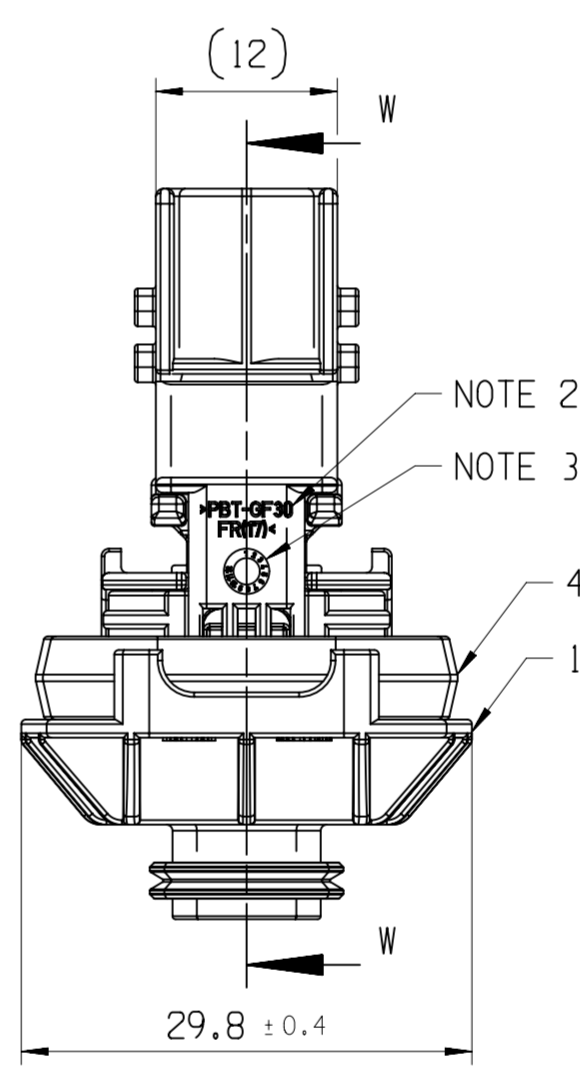
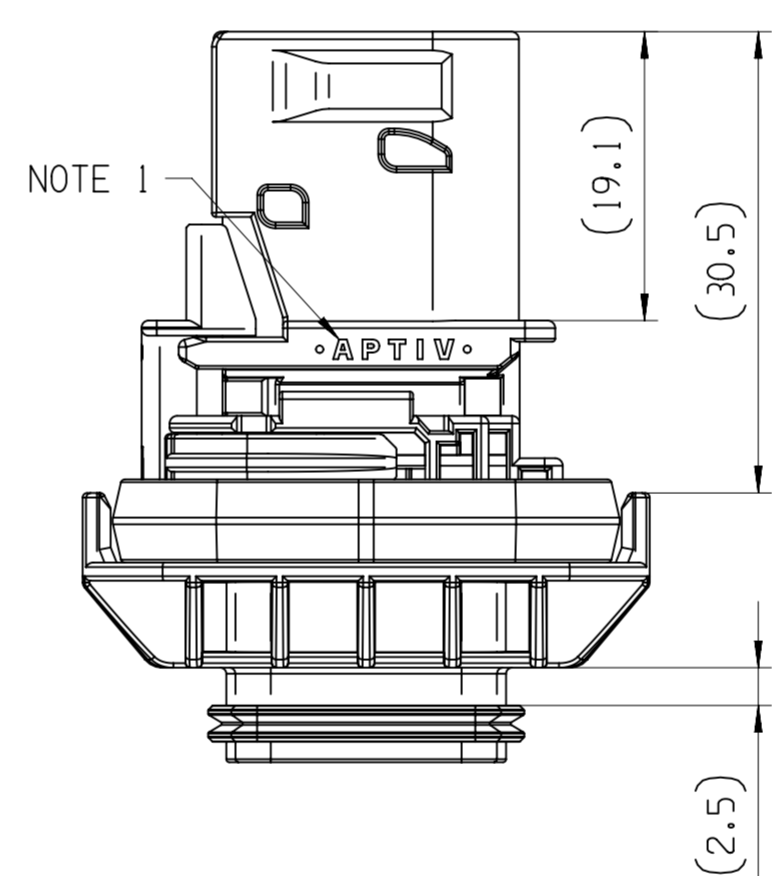
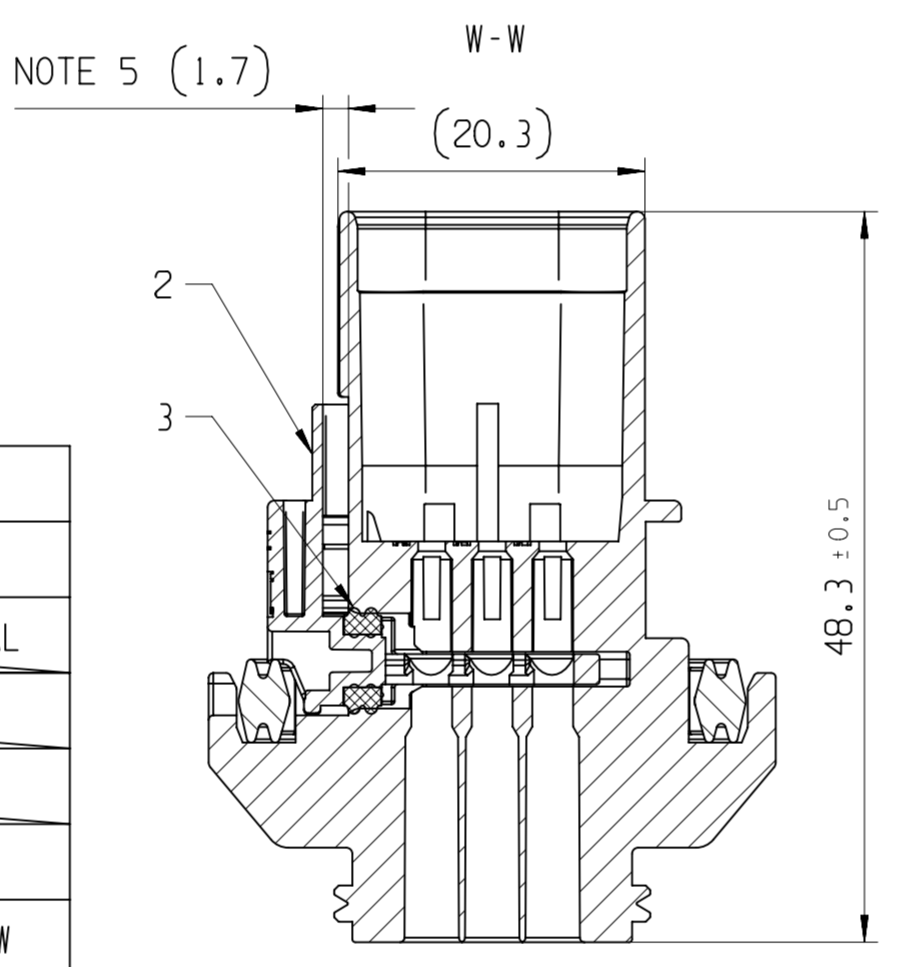
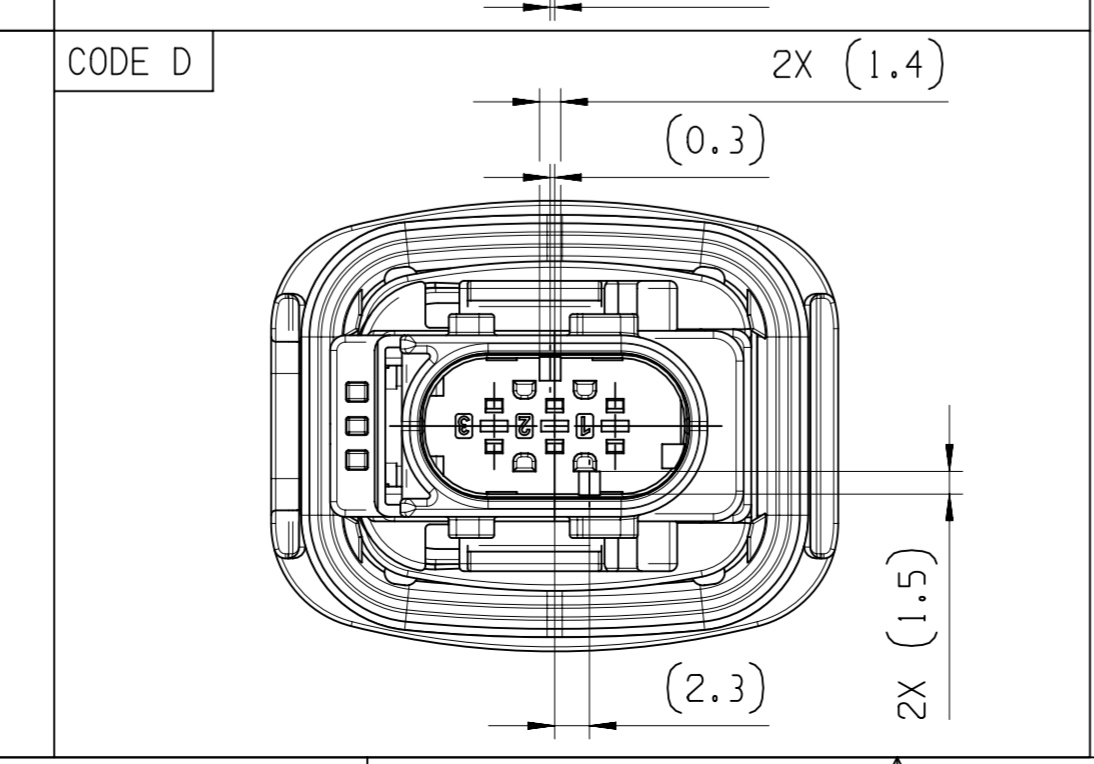
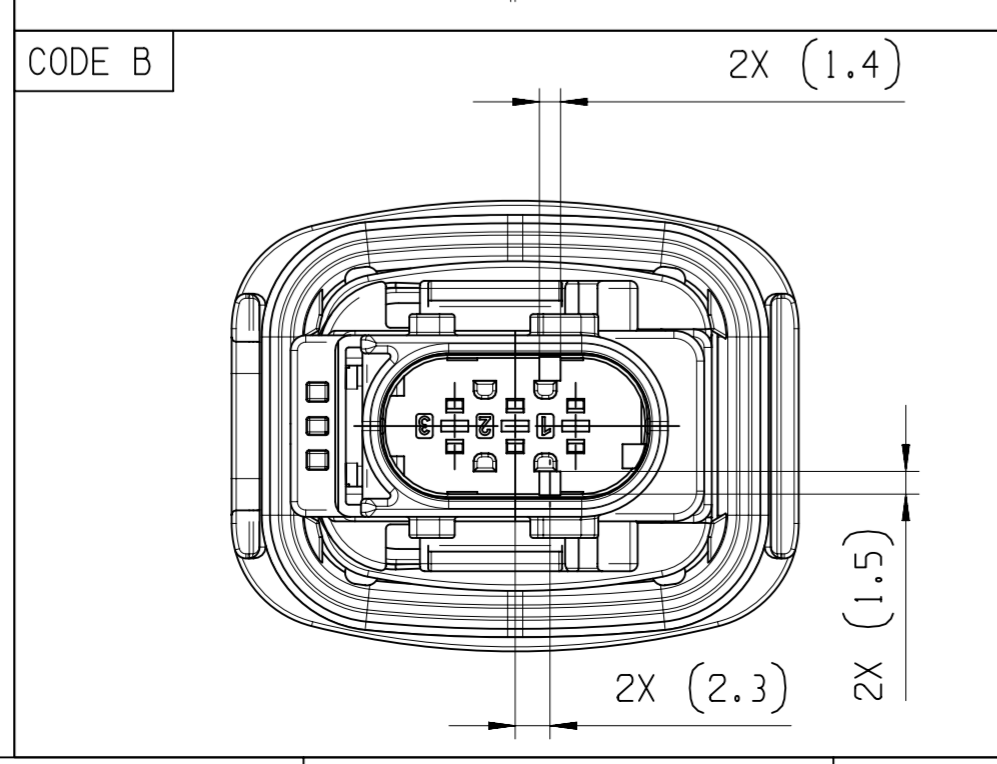
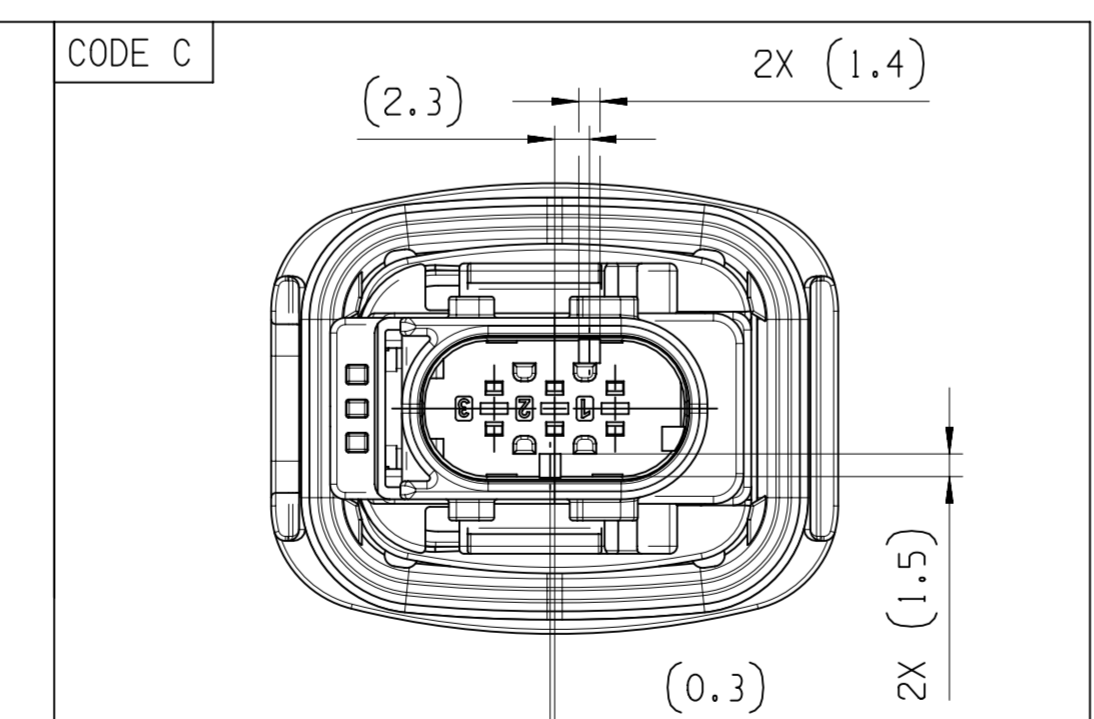
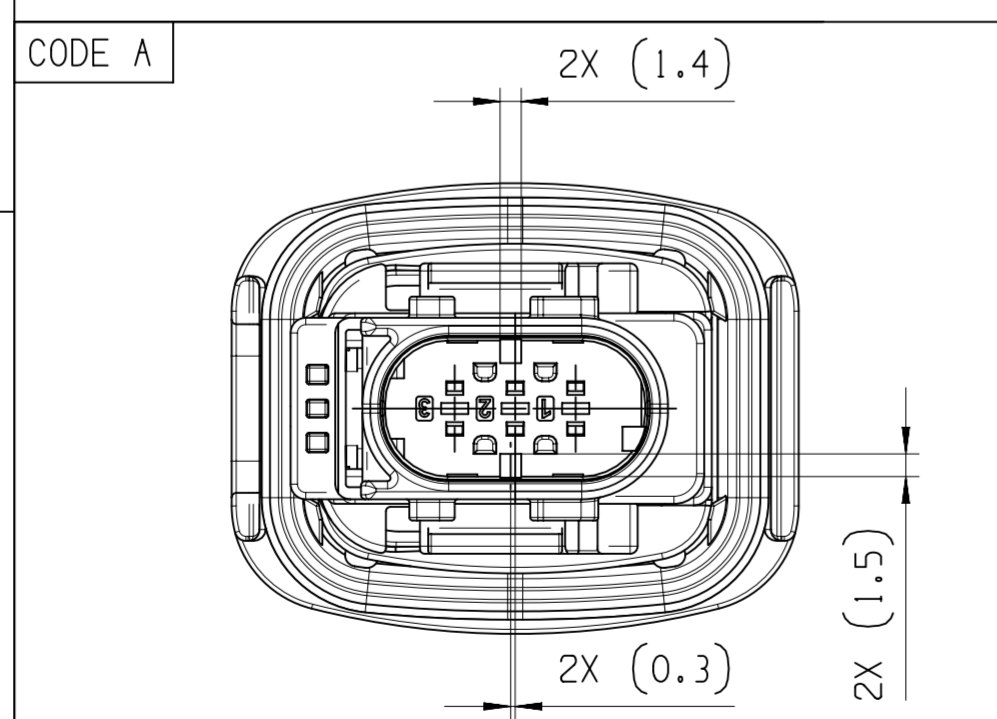

DIM TO CHECK	DIMENSIONAL RANGE (MM)												CHART	EL	
	FROM	> 0	> 20	> 30	> 70	> 100	> 150	> 200	> 250	> 300	> 400				
() DIM FOR HELP															
THEORETIC DIM	±0.15	±0.2	±0.3	±0.4	±0.5	±0.6	±0.8	±1	±1.2						

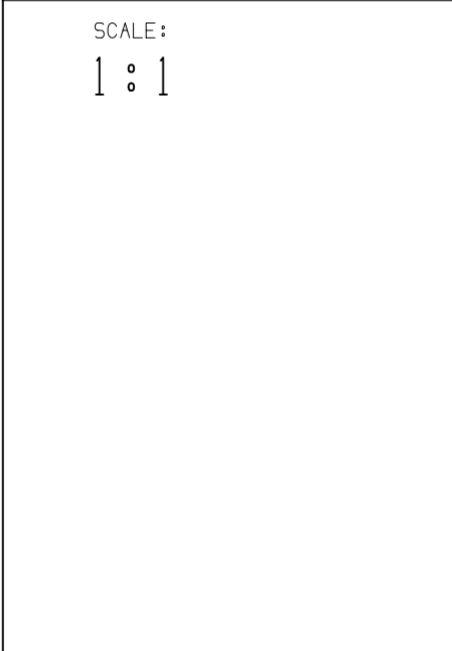

DWG TYP: PART DRAWING

WEIGHT (GR):

VOLUME (CM³):

ROUTING:

UNLESS OTHERWISE SPECIFIED

GENERAL TOLERANCES ACCORDING TO: SEE CHART

GD&T ACCORDING TO: ISO 1101

REFERENCE:

FIRST ANGLE PROJECTION

DO NOT SCALE

USE MATH DATA

• APTIV •

CONNECTION SYSTEMS
KRAKOW, POLAND
COPYRIGHT 2018 APTIV. ALL RIGHTS RESERVED.

THIS DRAWING IS THE PROPERTY OF APTIV AND CONTAINS APTIV CONFIDENTIAL INFORMATION. THE REPRODUCTION, DISTRIBUTION AND UTILIZATION OF THIS DOCUMENT OR ITS RELATED CAD MATH DATA, AS WELL AS COMMUNICATION OF ANY CONTENT TO OTHERS, WITHOUT EXPRESS AUTHORIZATION, IS PROHIBITED.

TEN RYSUNEK JEST WLASNOSCIA APTIV I ZAWIERA POUFNE INFORMACJE POWIELANE, ROZPOWISZCZANIE I WYKORZYSTYWANIE TEGO DOKUMENTU LUB ZWIAZANYCH Z NIM DANYCH CAD, JAK ROWNIEZ PRZEKAZYWANIE INNYM JAKIEKOLWIEK ICH ZAWARTOSC, BEZ NADANA WYRAZNYCH UPRAWNIEN, JEST ZABRONIONE.

	DATE
DR	K.FARON
APVD1	P.NAJDUCH
APVD2	M.GRUDZEWSKI
APVD3	
APVD4	
APVD5	

SUBSTANCES OF CONCERN AND RECYCLED CONTENT PER APTIV 10949001 SUBSTANCJE NIEBEZPIECZNE I POWTORNIE PRZETWORZONE OKRESLA APTIV 10949001

MATERIAL: SEE CHART

DRAWING NAME: 3 WAY 1.5 CTCS PANEL MOUNT MALE ASSEMBLY

DRAWING NUMBER: 33254299

SIZE	SCALE	FRAME NO	SHEET NO	STG	REV	N/P	AB
A1	2:1	1 OF 1	1 OF 1	R	01		AB

Mouser Electronics

Authorized Distributor

Click to View Pricing, Inventory, Delivery & Lifecycle Information:

[Aptiv:](#)

[33254281](#)