

- NOTE :
- 1 - CONFORM TO STANDARD IEC62196 AND DELPHI SPECIFICATIONS :
 - DELPHI SPECIFICATION FE-PS-13-027
 - TEMPERATURE CLASS OF THE CONNECTOR : -40°C ; +125°C
 - VIBRATION CLASS : CAR BODY LEVEL
 - POLLUTION LEVEL : CLASS 4
 - SEALING CLASS : IP55 IN ROAD POSITION IPP4 WITH CONNECTOR MATED
 - MATING / UNMATING FORCE : 80N MAX
 - DIELECTRIC TEST : WITH DRINKING WATER
 - RESISTANCE TO FLUID WITH G5 COOLANT LIQUID : INSULATION RESISTANCE > 0.8Mohm
 - 2 - PACKAGING : FE-PA-14-008
 - 3 - HANDLING MANUAL : PUI83
 - 4 - MASS OF THE PRODUCT : 0.189 kg ±5%
 - 5 - NO AGGRESSIVE SHAPE
 - 6 - FLAP SEALING IS INSURED BY MEANS OF SPRING CLOSING AND A LATCH
 - 7 - TIGHTNING TORQUE: SEE HANDLING MANUAL
 - 8 - MARKING :
 - 8 - 1 : DATE
 - 8 - 2 : MATERIAL
 - 8 - 3 : PART REVISION
 - 8 - 4 : CAVITY MOLD NUMBER : ONE CHARACTERS

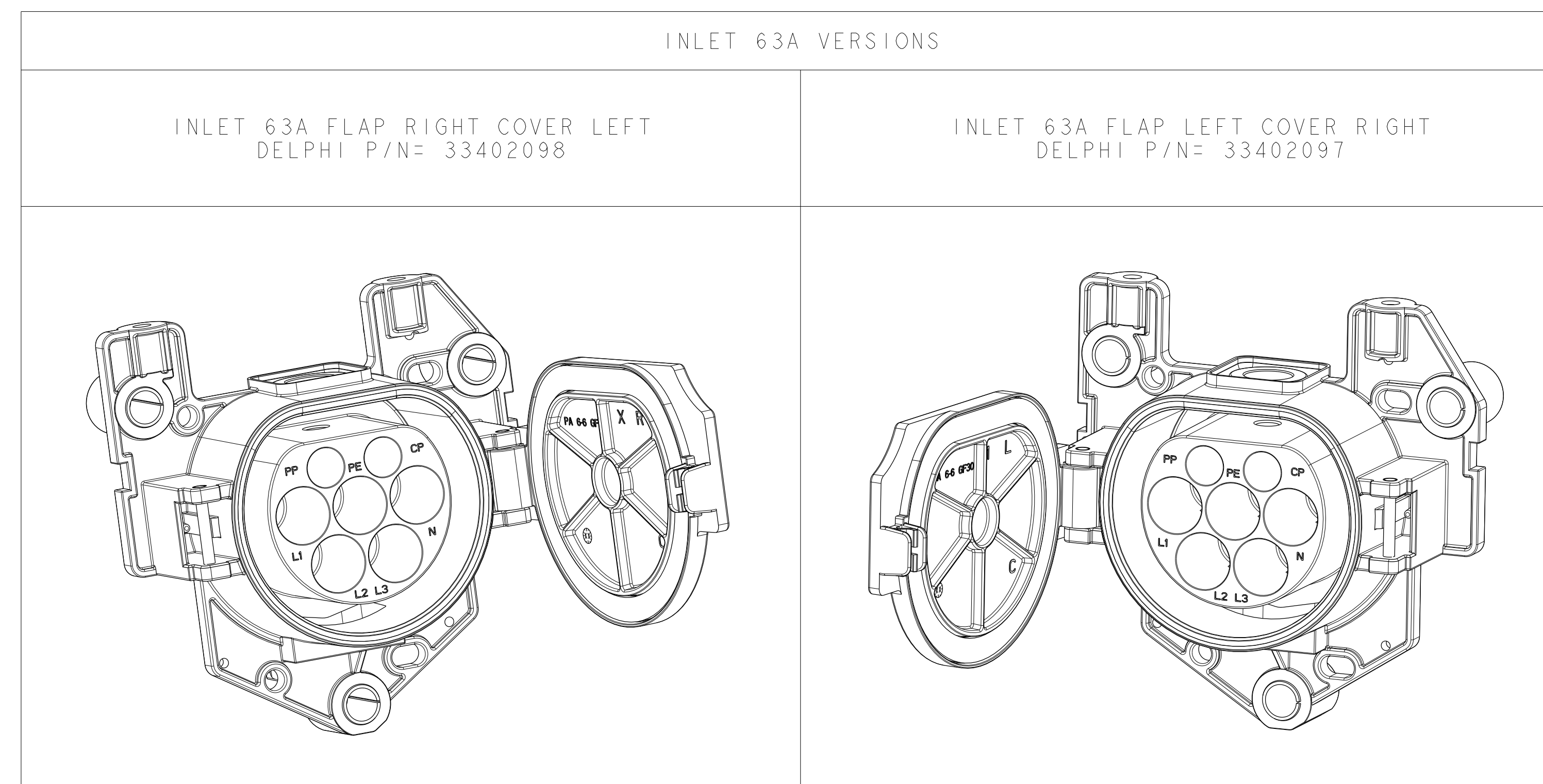

DESIGNATION	DELPHI PART NUMBER	DELPHI PART REVISION	IMDS N°
INLET 63A FLAP RIGHT COVER LEFT	33402098	01	471236432
INLET 63A FLAP LEFT COVER RIGHT	33402097	01	471236501

COMPONENTS TABLE CONSTITUANT THE PRODUCT				
REPERE	QUANTITY	COLOR	TITLE	MATERIAL
1	1	BLACK	INLET HOUSING LEFT	PA66 GF30
			INLET HOUSING RIGHT	
2	1	NA	INLET SPRING	STAINLESS STEEL
3	1	BLACK	INLET SLIDER	PA66 GF30
4	1	NA	INLET CYLINDER BALL	STAINLESS STEEL
5	1	BLACK	INLET FLAT SEAL	FOAM
6	1	BLACK	INLET RIGHT FLAP	PA66 GF30
			INLET LEFT FLAP	
7	2	NA	INLET STUB	STAINLESS STEEL
8	3	NA	INLET INSERT	STEEL + ZnNi
9	1	BLACK	INLET COVER SEAL DMS	FOAM

ASSOCIATED PARTS (FOR INFORMATION ONLY)			
DESIGNATION	PLATING	MVL PART N°	DELPHI PART N°
INLET TPA		F501410	33508692
MALE TERMINAL Ø 6mm WITH CAP FOR 4 ²	Ni 5µm TO 8µm	F432410	33502195
MALE TERMINAL Ø 6mm WITHOUT CAP FOR 16 ²		F532410	33502209
MALE TERMINAL Ø 3mm LONG FOR 0.5 ²		F732410	33502238
MALE TERMINAL Ø 3mm SHORT FOR 0.5 ²		F832410	33502256
MALE TERMINAL Ø 6mm WITH CAP FOR 16 ²	Ag 40µm	F613510	33513985
THERMO SENSOR		F373410	-
INLET COVER LEFT		-	33400030
INLET COVER RIGHT		-	33400076
INLET SCREW Ø 3.5mm L9mm		F028010	-
REAR GROMMET TUBE WITH CODING		-	33401379

14-01381

INITIAL ISSUE

DELPHI

SURASSY INLET 63A GENERIC

CHARGE PLUG

PC0840297

SERIAL RELEASED

See Table

Mouser Electronics

Authorized Distributor

Click to View Pricing, Inventory, Delivery & Lifecycle Information:

[Aptiv:](#)

[33402098](#)