

Notes / Bemerkungen		No.
1	Wire extraction force out of the wire crimp see: <i>Ausreißkraft des Leiters aus dem Drahtcrimp siehe:</i>	DIN EN 60352-2 Table 1
2	General guidelines for application of terminals with open crimp barrels is valid to Delphi-Specification <i>Es gelten die allgemeinen Richtlinien zur Verarbeitung von Kontakten mit offenen Crimphülsen nach Delphi-Spezifikation</i>	9 902 00 20 Rev. B
3	Dimension for part separating / <i>Masze fuer Teilevereinzelung</i>	---
4	Burr height / <i>Grathöhe</i>	max.0.3
5	For wire section 0.5mm ² unsuitable <i>Fuer Kabelquerschnitt 0.5mm² nicht geeignet</i>	---
6	For wire section 0.75mm ² unsuitable <i>Fuer Kabelquerschnitt 0.75mm² nicht geeignet</i>	---
7	only suitable for cavities with enlarged cable outlet (Ø 2.2 Cavity drawing note 6) <i>nur fuer Kamern mit Kabelerweiterung geeignet (Ø 2.2-Kammerzchnng. Notiz 6)</i>	---
Cross references / <i>Querverweise</i>		
8 Drawing terminal / <i>Kontaktteilzeichnung</i>		
a)	DT Female terminal with lance / <i>DT Kontakt mit Lanze</i>	6 008 01 11
b)	DT Female terminal lanceless / <i>DT Kontakt ohne Lanze</i>	6 008 11 11
c)	DT Male Terminal with lance / <i>DT Stecker mit Lanze</i>	6 018 10 01
d)	DT Female terminal with lance and short circuit area <i>DT Kontakt mit Lanze und Kurzschlussbrueckenbereich</i>	6 008 25 34
9 Cavity Drawing / <i>Kammerzeichnung</i>		
a)	DT Female terminal with lance / <i>DT Kontakt mit Lanze</i>	9 008 06 00
b)	DT Female terminal lanceless / <i>DT Kontakt ohne Lanze</i>	9 008 05 00
c)	DT Male Terminal with lance / <i>DT Stecker mit Lanze</i>	9 909 07 70
10 Productspecification / <i>Produktspezifikation</i>		
a)	DT Female terminal with lance / <i>DT Kontakt mit Lanze</i>	9 901 02 60
b)	DT Female terminal lanceless / <i>DT Kontakt ohne Lanze</i>	9 901 02 61
Symbol key / <i>Zeichenerklaerung</i>		
11	Functional dimensions / <i>Funktionsbestimmende Masze</i>	---
12	Only the german language shall be binding <i>Massgebend ist nur der deutsche Text</i>	---

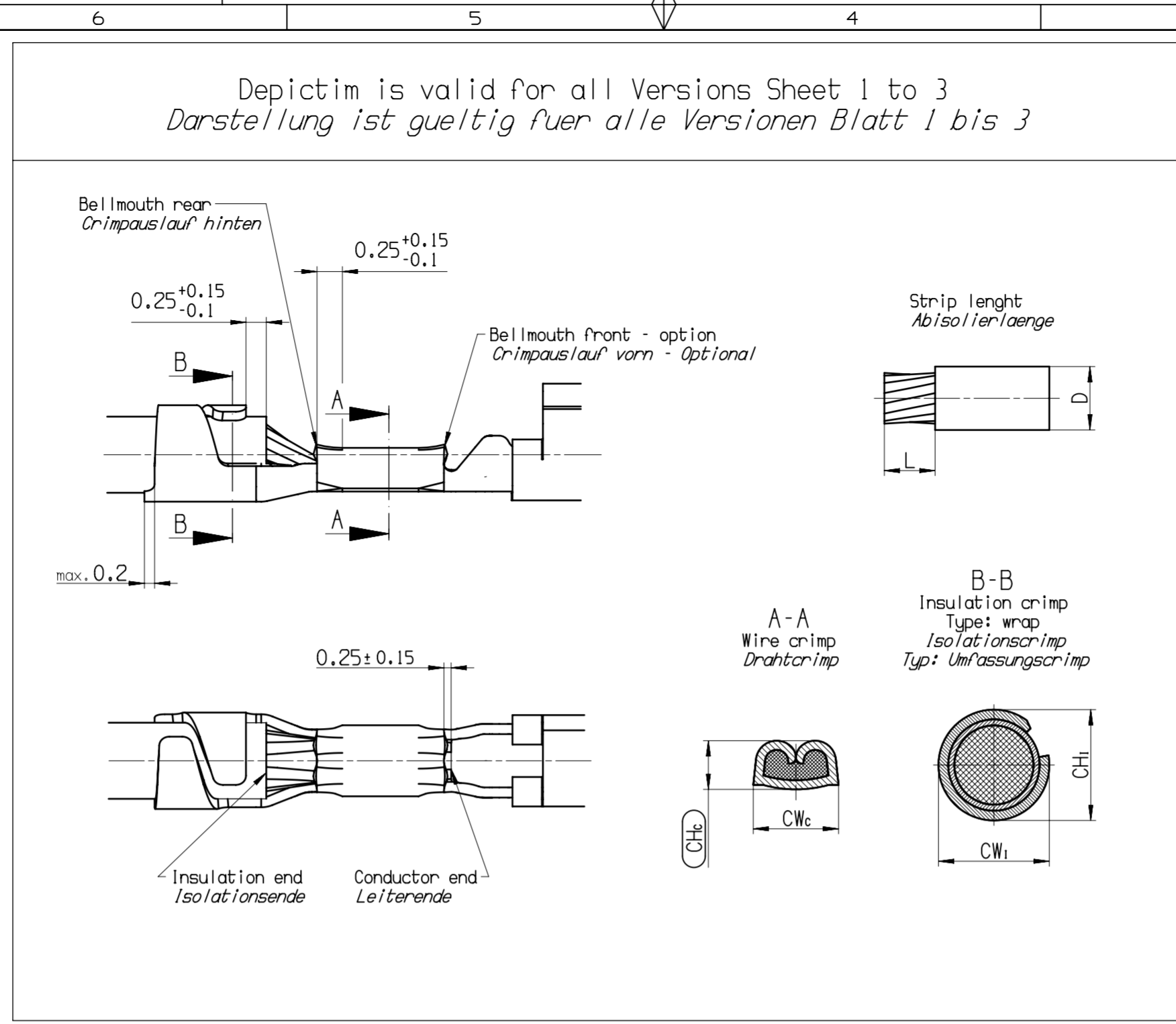

DWG STATUS					ZONE	REVISION HISTORY				AUTH	DR	APVD 1	APVD 2
DATE	STG	REV	N/P	CHG									
03Au16	R	04				Replace of Crimpspecification 90841210 Crimp range 0.12-0.18 withdrawn					SW	PN	SW
08Au16	R	04	AA			part no. corrected at Page 3					SW	PN	SW
22No16	R	04	AB			see Sheet 3					SW	PN	SW

this specification replaced the MVL Specification
diese Spezifikation ersetzt die MVL Spezifikation
9 084 12 10

Duo Twin 0.64
Female Terminal with lance
Buchsenkontakt mit Rastlanze

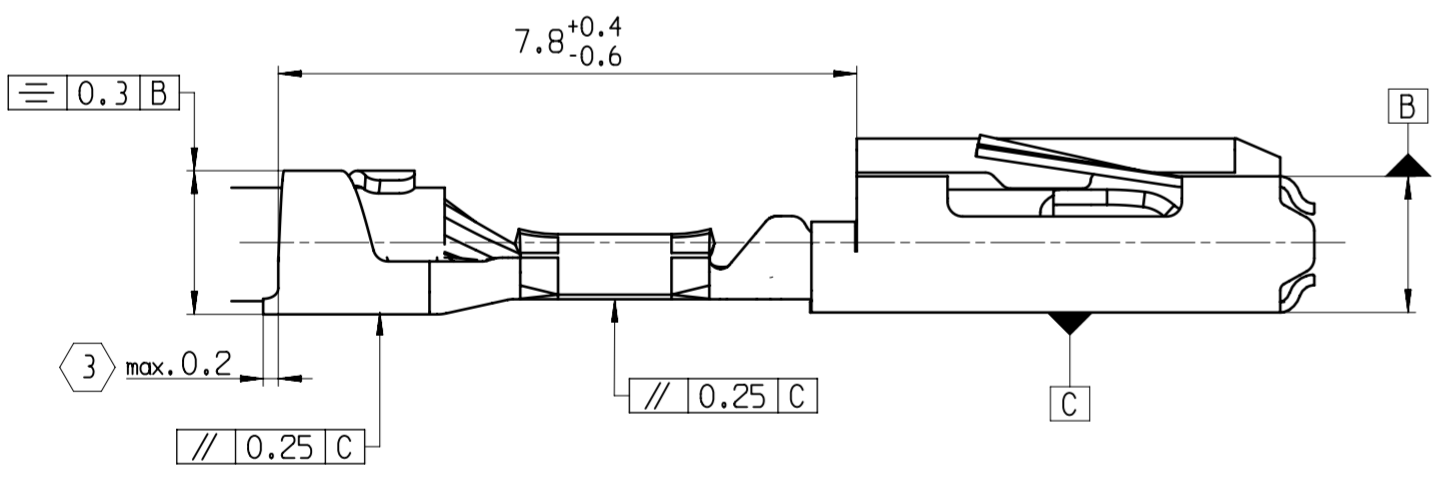

F928600	33504699	0.50-0.75	0.75	FLR	1.70-1.90	3.5	0.94	1.61	2.00	2.10 ^{+0.03} _{-0.10}	7	65200604		
F828600	33503452													
F728600	33504722													
F628600	33504701													
60080131	10820518	0.50 (0.75)	0.75	FLR	1.70-1.90	3.5	1.07	1.47	2.00	2.10 ^{+0.03} _{-0.10}	7	65200603		
60080134	33500666													
60080534	33500672													
60081434	13825968													
60082431	33504698	0.5	FLR	1.40-1.60	3.2	0.93	1.45	1.70	2.05 ^{+0.08} _{-0.10}	7	65200605			
60080111	10820519	0.22-0.35 (0.50)	0.50	FLR		1.40-1.60	3.2	0.86	1.45	1.70		2.05 ^{+0.08} _{-0.10}	7	65200602
60080114	33500664													
60080514	33500671													
60081414	13825967													
60082411	33501001	0.22	FLR	1.10-1.20		0.74	1.30	1.40	1.70±0.1			65200601		
MVL	Delphi	Crimp area <i>Kabelbereich</i>	Wire size <i>Kabelquerschnitt</i>	Type	D (mm)	L±0.2	CH ₁ ±0.03	CW ₂ ±0.05	CH ₁ ±0.05	CW ₁		Applicator no.		
Part Nr. <i>Teile Nr.</i>					Wire / Kabel		Wire crimp <i>Drahtcrimp</i>		Insulation crimp <i>Isolationscrimp</i>					

DWG TYP
CUSTOMER PART DRAWING

WEIGHT (GR) _____ DISTR CODE _____

VOLUME (CM³) _____

ROUTING _____

UNLESS OTHERWISE SPECIFIED

GENERAL TOLERANCES ACCORDING TO:
DIN ISO 2768-*PH*
Masze ≤0.5 = ±0.05

GD&T ACCORDING TO:
DIN EN ISO 1101

REFERENCE _____

FIRST ANGLE PROJECTION

DO NOT SCALE
USE MATH DATA

CAD NX

DELPHI

DELPHI PACKARD ELECTRICAL/ELECTRONIC ARCHITECTURE
Epernon, France

COPYRIGHT 2016 DELPHI CORPORATION AND/OR ITS AFFILIATES. ALL RIGHTS RESERVED.

THIS DRAWING IS THE PROPERTY OF DELPHI CORPORATION AND CONTAINS DELPHI CONFIDENTIAL INFORMATION. THE REPRODUCTION, DISTRIBUTION AND UTILIZATION OF THIS DOCUMENT OR ITS RELATED CAD MATH DATA, AS WELL AS COMMUNICATION OF ANY CONTENT TO OTHERS, WITHOUT EXPRESS AUTHORIZATION, IS PROHIBITED.

DIESE ZEICHNUNG IST EIGENTUM DER FIRMA DELPHI UND ENTHAELT DELPHI VERTRAULICHE INFORMATIONEN. DIE REPRODUKTION, VERTEILUNG UND NUTZUNG DIESES DOKUMENTES ODER DEREN ZUGEHORIGEN CAD DATEN, ODER AUCH ALS KOMMUNIKATION VON BELIEBIGEN INHALT ZU ANDEREN, IST OHNE BERECHTIGUNGSPRUEFUNG DURCH DIE DELPHI CORPORATION UNZULAESSIG.

DR	S.Weiss	DATE	03Au16
APVD1	S.Weiss		03Au16
APVD2	P.Nuetzel		03Au16
APVD3			
APVD4			
APVD5			

SUBSTANCES OF CONCERN AND RECYCLED CONTENT PER DELPHI 10949001
POTENTIELL GEFAEHRLICHE STOFFE UND REZYKLATANTEIL
GEMAESS DELPHI 10949001

MATERIAL _____

DRAWING NAME
Crimpspecification
Terminal System - Duo Twin 0.64

DRAWING NUMBER
CUS02
1 3599 348

SIZE	SCALE	FRAME NO	SHEET NO	STG	REV	N/P
A2	10:1	1 OF 1	1 OF 3	R	04	AB

Notes / Bemerkungen		
1	Wire extraction force out of the wire crimp see: <i>Ausreißkraft des Leiters aus dem Drahtcrimp siehe:</i>	DIN EN 60352-2 Table 1
2	General guidelines for application of terminals with open crimp barrels is valid to Delphi-Specification <i>Es gelten die allgemeinen Richtlinien zur Verarbeitung von Kontakten mit offenen Crimphülsen nach Delphi-Spezifikation</i>	9 902 00 20 Rev. B
3	Dimension for part separating / <i>Masz fuer Teilevereinzlung</i>	---
4	Burr height / <i>Grathoehhe</i>	max.0.3
5	For wire section 0.5mm ² unsuitable (outdated use) <i>Fuer Kabelquerschnitt 0.5mm² nicht geeignet (veraltete Anwendung)</i>	---
6	For wire section 0.75mm ² unsuitable (outdated use) <i>Fuer Kabelquerschnitt 0.75mm² nicht geeignet (veraltete Anwendung)</i>	---
7	only suitable for cavity with enlarged cable outlet (ϕ 2.2 Cavity drawing note 7) <i>nur fuer Kammern mit Kabelerweiterung geeignet (ϕ 2.2-Kammerzchnng, Notiz 7)</i>	
Cross references / <i>Querverweise</i>		
8	Drawing terminal / <i>Kontaktteilzeichnung</i> a) Female terminal with lance / <i>Kontakt mit Lanze</i> b) Female terminal lanceless / <i>Kontakt ohne Lanze</i> c) Male Terminal with lance / <i>Stecker mit Lanze</i> d) Female terminal with lance and jumper area <i>Kontakt mit Lanze und Kurzschlussbrueckenbereich</i>	6 008 01 11 6 008 11 11 6 018 10 01 6 008 25 34
9	Cavity Drawing / <i>Kammerzeichnung</i> a) Female terminal with lance / <i>Kontakt mit Lanze</i> b) Female terminal lanceless / <i>Kontakt ohne Lanze</i> c) Male Terminal with lance / <i>Stecker mit Lanze</i>	9 008 06 00 9 008 05 00 9 909 07 70
10	Productspecification / <i>Produktspezifikation</i> a) Female terminal with lance / <i>Kontakt mit Lanze</i> b) Female terminal lanceless / <i>Kontakt ohne Lanze</i>	9 901 02 60 9 901 02 61
Symbol key / <i>Zeichenerklaerung</i>		
11	Functional dimensions / <i>Funktionsbestimmende Masze</i>	---
12	Missing dimensions and informations see sheet 1 <i>fehlende Masze und Informationen siehe Blatt 1</i>	---
13	Only the german language shall be binding <i>Massgebend ist nur der deutsche Text</i>	---

Duo Twin 0.64
Female Terminal lanceless
Buchsernkontakt ohne Rastlanze

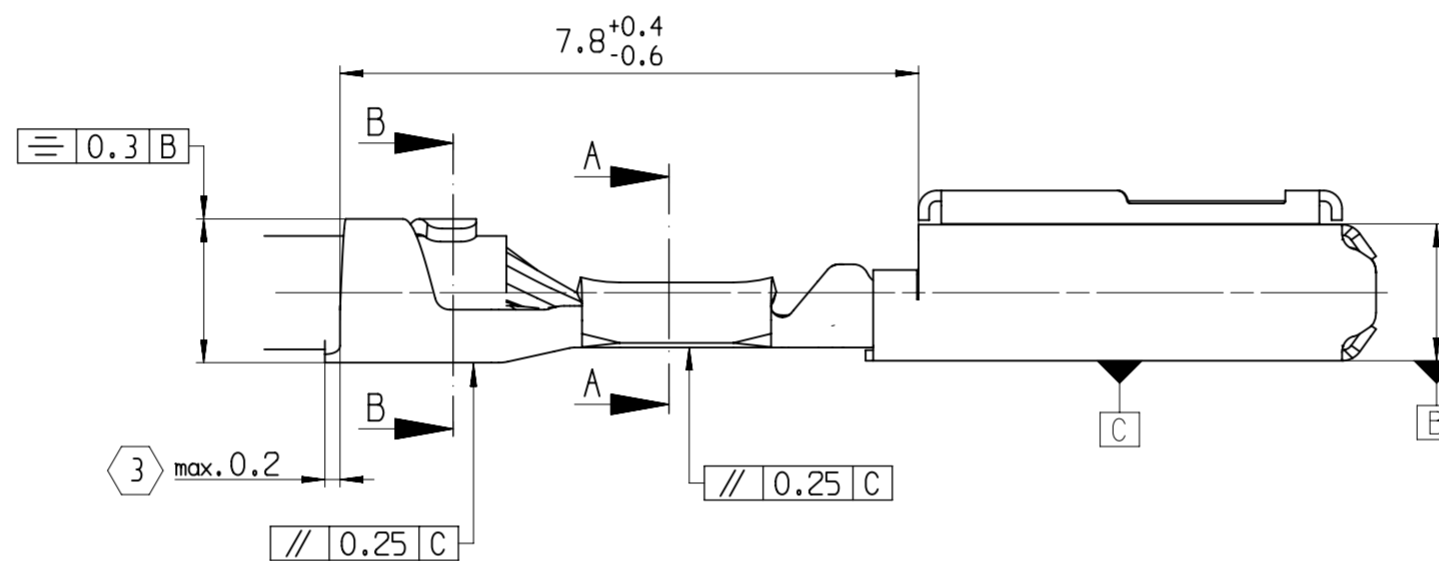

this specification
replaced the MVL Specification
*diese Spezifikation
ersetzt die MVL Spezifikation*
9 084 12 10

DWG TYP CUSTOMER PART DRAWING	
WEIGHT (GR)	DISTR CODE
VOLUME (CM ³)	D
ROUTING	

UNLESS OTHERWISE SPECIFIED
GENERAL TOLERANCES
ACCORDING TO:
DIN ISO 2768-FH
Masze $\leq 0.5 = \pm 0.05$

GD&T
ACCORDING TO:
DIN EN ISO 1101

REFERENCE

FIRST ANGLE PROJECTION

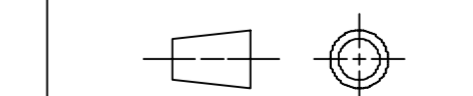

DO NOT SCALE
USE MATH DATA

DELPHI

DELPHI PACKARD ELECTRICAL/ELECTRONIC ARCHITECTURE
Epernon, France

COPYRIGHT 2016 DELPHI CORPORATION AND/OR ITS AFFILIATES.
ALL RIGHTS RESERVED.

THIS DRAWING IS THE PROPERTY OF DELPHI CORPORATION
AND CONTAINS DELPHI CONFIDENTIAL INFORMATION.
THE REPRODUCTION, DISTRIBUTION AND UTILIZATION
OF THIS DOCUMENT OR ITS RELATED CAD MATH DATA,
AS WELL AS COMMUNICATION OF ANY CONTENT TO OTHERS,
WITHOUT EXPRESS AUTHORIZATION, IS PROHIBITED.

DIESE ZEICHNUNG IST EIGENTUM DER FIRMA DELPHI UND ENTHAELT DELPHI
VERTRAULICHE INFORMATIONEN. DIE REPRODUKTION, VERTEILUNG UND
NUTZUNG DIESES DOKUMENTES ODER DEREN ZUGEHÖRIGEN CAD DATEN, ODER
AUCH ALS KOMMUNIKATION VON BELIEBIGEN INHALT ZU ANDEREN, IST OHNE
BERECHTIGUNGSPRUEFUNG DURCH DIE DELPHI CORPORATION UNZULÄSSIG

DATE	
DR	S.Weiss 03Au16
APVD1	S.Weiss 03Au16
APVD2	P.Nuetzel 03Au16
APVD3	
APVD4	
APVD5	

SUBSTANCES OF CONCERN AND RECYCLED CONTENT PER DELPHI 10949001
POTENTIELL GEFAEHRLICHE STOFFE UND REZYKLATANTEIL
GEMAES DELPHI 10949001

MATERIAL

DRAWING NAME
Crimpspecification
Terminal System - Duo Twin 0.64

CUS02

DRAWING NUMBER
1 3599 348

SIZE	SCALE	FRAME NO	SHEET NO	STG	REV	N/P
A2	10:1	1 OF 1	2 OF 3	R	04	AB

F538600	33504516	0.50-0.75	0.75	FLR	1.70-1.90	3.5	0.94	1.61	2.00	2.10 ^{+0.03} -0.10	65200604
F438600	33504702										
F338600	33504703										
F238600	33504704										
F038600	33504705										
F323310	33514136 33320658 33333596	0.50	FLR	1.40-1.60	3.5	0.91	1.61	1.70	2.05 ^{+0.08} -0.10	65200612	
F351410	33515623	0.50-0.75	0.50	FLR	1.40-1.60	3.5	0.91	1.61	1.70	2.05 ^{+0.08} -0.10	65200612
60081131	13577654	0.50 (0.75)	0.75	FLR	1.70-1.90	3.5	1.07	1.47	2.00	2.10 ^{+0.03} -0.10	65200603
60081134	13798988		0.60	---	1.70-1.85		1.00	1.45	2.0	2.10 ^{+0.03} -0.10	
60082124	33504710		AWG 20	---	1.70-1.85		0.95	1.40	2.00	2.10 ^{+0.03} -0.10	
60082034	13589018		0.5	FLR	1.40-1.60		0.93	1.45	1.70	2.05 ^{+0.08} -0.10	
F479100	33500997										
60081111	13651155	0.22-0.35 (0.50)	0.50	FLR	1.40-1.60	3.2	0.86	1.45	1.70	2.05 ^{+0.08} -0.10	65200602
60081114	13577653		AWG 22	---	1.50-1.65		0.76	1.45	1.80	2.05 ^{+0.08} -0.10	
60082014	13589019		0.35	FLR	1.20-1.40		0.76	1.44	1.50	1.75 \pm 0.1	
60082114	33504713		0.22	FLR	1.10-1.20		0.74	1.30	1.40	1.70 \pm 0.1	
F079100	33501000										
F223310	33517251 33320659 33333595										
F251410	33515624	0.22-0.35	0.35	FLR	1.20-1.40		0.76	1.44	1.50	1.75 \pm 0.1	65200611
MVL	Delphi	Crimp area <i>Crimp- bereich</i>	Wire size <i>Kabel- querschnitt</i>	Type	D (mm)	L \pm 0.2	CH ₁ \pm 0.03	CW ₂ \pm 0.05	CH ₂ \pm 0.05	CW ₁	Applicator no.
Part Nr. <i>Teile Nr.</i>		mm ²	mm ²		Wire / Kabel		Wire crimp <i>Drahtcrimp</i>		Insulation crimp <i>Isolationscrimp</i>		

DWG STATUS					ZONE	REVISION HISTORY			AUTH	DR	APVD 1	APVD 2
DATE	STG	REV	N/P	CHG								
03Au16	R	04				Replace of Crimpspecification 90841210						
08Au16	R	04	AA		A8	Part no. corrected				SW	PN	SW
22N016	R	04	AB			Crimp area corrected was 0.5-.075				SW	PN	SW

Duo Twin 0.64
Male Terminal with lance
Stecker mit Rastlanze

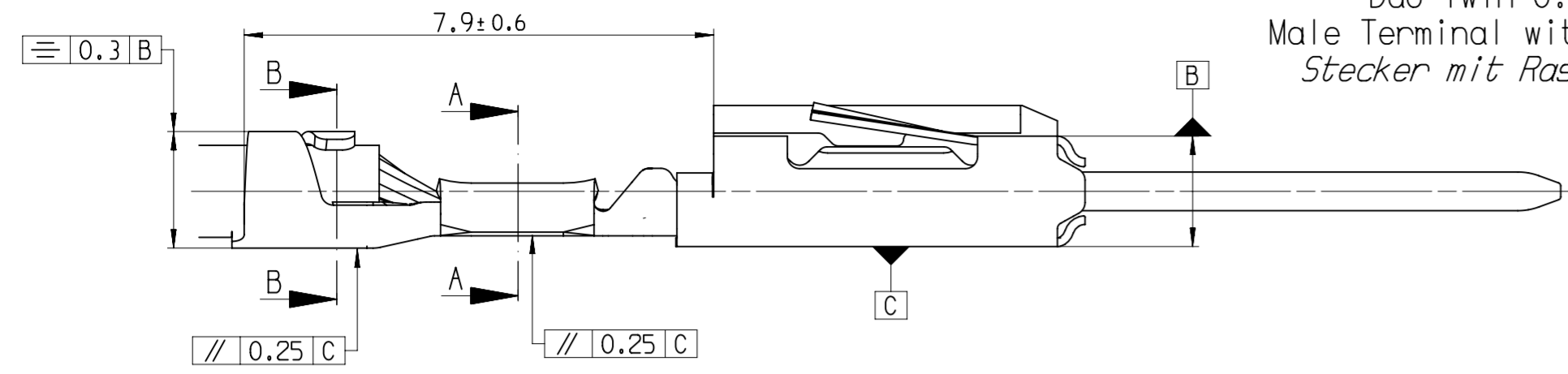

MVL	Delphi	Crimp area Crimp- bereich mm²	Wire size Kabel- querschnitt mm²	Type	D (mm)	L±0.2	CH ₁ ±0.03	CW ₁ ±0.05	CH ₂ ±0.05	CW ₂	Applicator no.
F402410 F691410	33504708 33504709 33400474 33400475 33405274 33405265	0.50-0.75	0.75	FLR	1.70-1.90	3.5	0.94	1.61	2.00	2.10 ^{+0.03} _{-0.10}	65200604
			0.50	---	1.40-1.60		0.91	1.61	1.70	2.05 ^{+0.08} _{-0.10}	
60181031 60181034	13669746 33500685	0.50 (0.75) 6	0.75	FLR	1.70-1.90	3.5	1.07	1.47	2.00	2.10 ^{+0.03} _{-0.10}	65200603
			0.60	---	1.70-1.85		1.00	1.45	2.0	2.10 ^{+0.03} _{-0.10}	
			AWG 20	---	1.70-1.85		0.95	1.40	2.00	2.10 ^{+0.03} _{-0.10}	
			0.5	FLR	1.40-1.60		0.93	1.45	1.70	2.05 ^{+0.08} _{-0.10}	
60181011 60181014	13668473 33500684 33400380 33400379 33405273 33405264	0.22-0.35 (0.50) 5	0.50	FLR	1.40-1.60	3.2	0.86	1.45	1.70	2.05 ^{+0.08} _{-0.10}	65200602
			AWG 22	---	1.50-1.65		0.76	1.45	1.80	2.05 ^{+0.08} _{-0.10}	
			0.35	FLR	1.20-1.40		0.76	1.44	1.50	1.75±0.1	
			0.22	FLR	1.10-1.20		0.74	1.30	1.40	1.70±0.1	65200601

this specification
replaced the MVL Specification
diese Spezifikation
ersetzt die MVL Spezifikation
9 084 12 10

Duo Twin 0.64
Female Terminal with lance and jumper area
Kontakt mit Rastlanze
und Kurzschlussbruecken Bereich

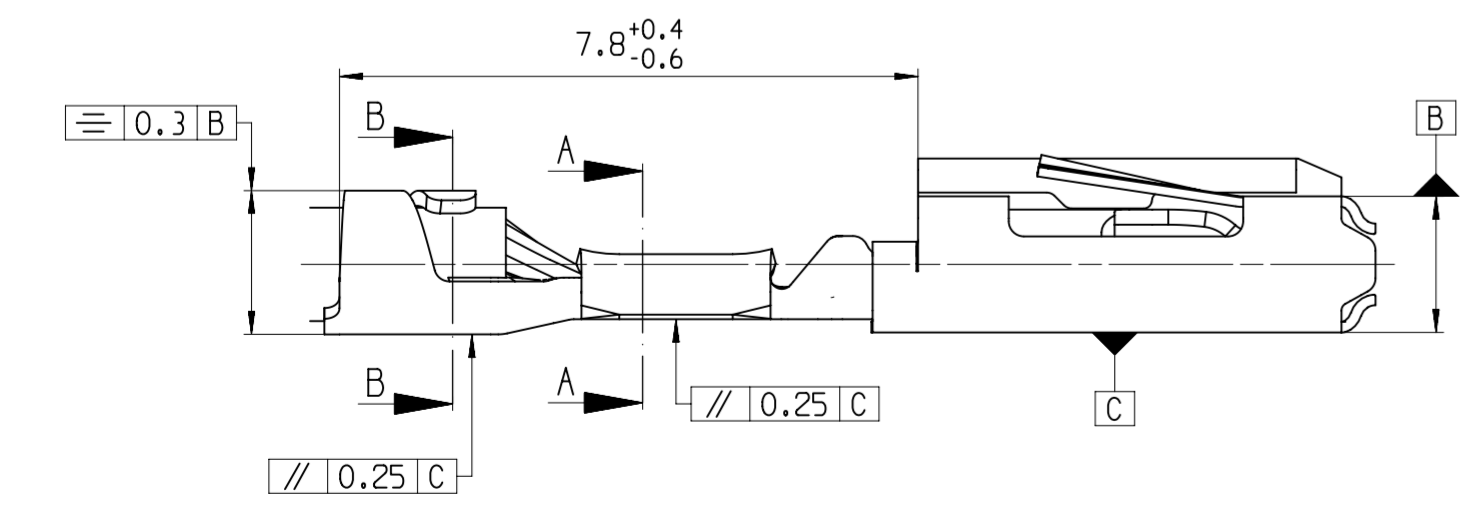
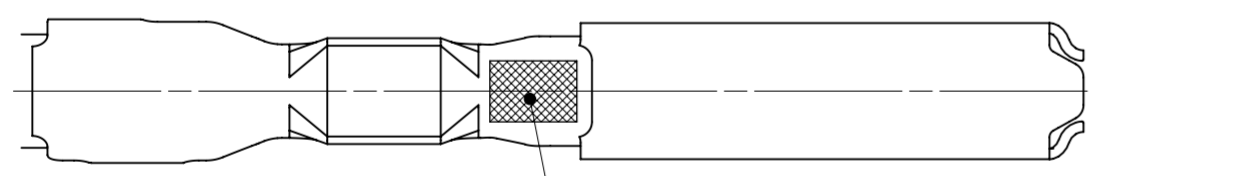

MVL	Delphi	Crimp area Crimp- bereich mm²	Wire size Kabel- querschnitt mm²	Type	D (mm)	L±0.2	CH ₁ ±0.03	CW ₁ ±0.05	CH ₂ ±0.05	CW ₂	Applicator no.
60082534 F076000	33513658 33513657	0.50	0.50	FLR	1.40-1.60	3.5	0.91	1.61	1.70	2.05 ^{+0.08} _{-0.10}	65200612

Notes / Bemerkungen		
1	Wire extraction force out of the wire crimp see: <i>Ausreißkraft des Leiters aus dem Drahtcrimp siehe:</i>	DIN EN 60352-2 Table 1
2	General guidelines for application of terminals with open crimp barrels is valid to Delphi-Specification <i>Es gelten die allgemeinen Richtlinien zur Verarbeitung von Kontakten mit offenen Crimphülsen nach Delphi-Spezifikation</i>	9 902 00 20 Rev. B
3	Dimension for part separating / <i>Masz fuer Teileverzelung</i>	---
4	Burr height / <i>Grathoeh</i>	max.0.3
5	For wire section 0.5mm² unsuitable (outdated use) <i>Fuer Kabelquerschnitt 0.5mm² nicht geeignet (veraltete Anwendung)</i>	---
6	For wire section 0.75mm² unsuitable (outdated use) <i>Fuer Kabelquerschnitt 0.75mm² nicht geeignet (veraltete Anwendung)</i>	---
7	only suitable for cavity with enlarged cable outlet (Ø 2.2 Cavity drawing note 6) <i>nur fuer Kamern mit Kabelerweiterung geeignet (Ø 2.2-Kammerzchg. Notiz 6)</i>	
Cross references / <i>Querverweise</i>		
8	Drawing terminal / <i>Kontaktteilzeichnung</i> a) Female terminal with lance / <i>Kontakt mit Lanze</i> b) Female terminal lanceless / <i>Kontakt ohne Lanze</i> c) Male Terminal with lance / <i>Stecker mit Lanze</i> d) Female terminal with lance and jumper area <i>Kontakt mit Lanze und Kurzschlussbrueckenbereich</i>	6 008 01 11 6 008 11 11 6 018 10 01 6 008 25 34
9	Cavity Drawing / <i>Kammerzeichnung</i> a) Female terminal with lance / <i>Kontakt mit Lanze</i> b) Female terminal lanceless / <i>Kontakt ohne Lanze</i> c) Male Terminal with lance / <i>Stecker mit Lanze</i>	9 908 06 00 9 908 05 00 9 909 07 70
10	Productspecification / <i>Produktspezifikation</i> a) Female terminal with lance / <i>Kontakt mit Lanze</i> b) Female terminal lanceless / <i>Kontakt ohne Lanze</i>	9 901 02 60 9 901 02 61
Symbol key / <i>Zeichenerklaerung</i>		
11	Functional dimensions / <i>Funktionsbestimmende Masze</i>	---
12	Missing dimensions and informations see sheet 1 <i>fehlende Masze und Informationen siehe Blatt 1</i>	---
13	Only the german language shall be binding <i>Massgebend ist nur der deutsche Text</i>	---

DWG TYP
CUSTOMER PART DRAWING

WEIGHT (GR) _____ DISTR CODE _____

VOLUME (CM³) _____

ROUTING _____

UNLESS OTHERWISE SPECIFIED

GENERAL TOLERANCES
ACCORDING TO:
DIN ISO 2768-CH
Masze ≤ 0.5 = ± 0.05

GD&T
ACCORDING TO:
DIN EN ISO 1101

REFERENCE

FIRST ANGLE PROJECTION

DO NOT SCALE

USE MATH DATA

DELPHI

DELPHI PACKARD ELECTRICAL/ELECTRONIC ARCHITECTURE
Epernon, France

COPYRIGHT 2016 DELPHI CORPORATION AND/OR ITS AFFILIATES.
ALL RIGHTS RESERVED.

THIS DRAWING IS THE PROPERTY OF DELPHI CORPORATION
AND CONTAINS DELPHI CONFIDENTIAL INFORMATION.
THE REPRODUCTION, DISTRIBUTION AND UTILIZATION
OF THIS DOCUMENT OR ITS RELATED CAD MATH DATA,
AS WELL AS COMMUNICATION OF ANY CONTENT TO OTHERS,
WITHOUT EXPRESS AUTHORIZATION, IS PROHIBITED.

DIESE ZEICHNUNG IST EIGENTUM DER FIRMA DELPHI UND ENTHAELT DELPHI
VERTRAULICHE INFORMATIONEN. DIE REPRODUKTION, VERTEILUNG UND
NUTZUNG DIESES DOKUMENTES ODER DEREN ZUGEHÖRIGEN CAD DATEN, ODER
AUCH ALS KOMMUNIKATION VON BELIEBIGEN INHALT ZU ANDEREN, IST OHNE
BERECHTIGUNGSPRUEFUNG DURCH DIE DELPHI CORPORATION UNZULAESSIG

DR	S.Weiss	03Au16
APVD1	S.Weiss	03Au16
APVD2	P.Nuetzel	03Au16
APVD3		
APVD4		
APVD5		

SUBSTANCES OF CONCERN AND RECYCLED CONTENT PER DELPHI 10949001
POTENTIELL GEFAEHRLICHE STOFFE UND REZYKLATANTEIL
GEMAES DELPHI 10949001

DRAWING NAME
Crimpspecification
Terminal System - Duo Twin 0.64

CUS02

DRAWING NUMBER
1 3599 348

SIZE	SCALE	FRAME NO	SHEET NO	STG	REV	N/P
A2	10:1	1 OF 1	3 OF 3	R	04	AB

Mouser Electronics

Authorized Distributor

Click to View Pricing, Inventory, Delivery & Lifecycle Information:

[Aptiv:](#)

[33504516](#)