



ULTRA HIGH DYNAMIC RANGE, SHUTDOWN

# Monolithic Amplifier

# TSS-23HLN+

50Ω 30 MHz to 2 GHz

## THE BIG DEAL

- High IP3, +42.6 dBm typ. at 1GHz
- Gain, 21.8 dB typ. at 1 GHz
- Low noise figure, 1.4 dB at 1 GHz
- High P1dB, +28.5 dBm at 1 GHz
- Shutdown feature

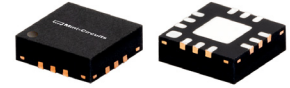

Generic photo used for illustration purposes only

CASE STYLE: DQ1225

### +RoHS Compliant

The +Suffix identifies RoHS Compliance. See our website for methodologies and qualifications

## APPLICATIONS

- Base station infrastructure
- CATV
- Cellular

## PRODUCT OVERVIEW

TSS-23HLN+ (RoHS compliant) is an advanced wideband amplifier with shutdown feature. It is fabricated using E-PHEMT technology and offers extremely high dynamic range over a broad frequency range and with low noise figure. In addition, the TSS-23HLN+ has good input and output return loss over a broad frequency range. TSS-23HLN+ is enclosed in a 3mm x 3mm, 12-lead MCLP package and has very good thermal performance.

## KEY FEATURES

Feature	Advantages
Broad Band: 30MHz to 2GHz	Broadband covering primary wireless communications bands: VHF, UHF, Cellular
Extremely High IP3 +39.6 dBm typical at 30 MHz +42.6 dBm typical at 1GHz	The TSS-23HLN+ matches industry leading IP3 performance relative to device size and power consumption. The combination of the design and E-PHEMT Structure provides enhanced linearity over a broad frequency range as evidence in the IP3 being approximately 13-15 dB above the P1dB point. This feature makes this amplifier ideal for use in: <ul style="list-style-type: none"> <li>• Driver amplifiers for complex waveform up converter paths</li> <li>• Drivers in linearized transmit systems</li> <li>• Secondary amplifiers in ultra-High Dynamic range receivers</li> </ul>
Shutdown feature	Allow users to turn on and off the amplifier with pulsed signals while keeping the power supply at constant voltage to minimize DC power consumption
Low Noise Figure, 1.4 dB at 1 GHz	Enables lower system noise figure performance and along with High OIP3 provides high dynamic range
High P1dB , +28.5 dBm at 1 GHz	High P1dB, High OIP3, Low NF results in a very dynamic range preventing amplifier saturation under strong interfering signals.

REV. B  
ECO-022590  
TSS-23HLN+  
MCL NY  
240731





ULTRA HIGH DYNAMIC RANGE, SHUTDOWN

# Monolithic Amplifier

# TSS-23HLN+

Mini-Circuits

## ELECTRICAL SPECIFICATIONS<sup>1</sup> AT +25°C & 50Ω, UNLESS NOTED OTHERWISE

Parameter	Condition (MHz)	Amplifier-ON VDD = +8V			Amplifier-OFF VDD = +8V	Units
		Min.	Typ.	Max.	Typ.	
Frequency Range		30		2000	30-2000	MHz
Noise Figure	30		1.4		—	dB
	500		1.4		—	
	1000		1.4		—	
	1500		1.5		—	
	2000		1.6		—	
Gain	30	20.9	23.3	25.5	-21	dB
	500	—	22.4	—	-21	
	1000	19.5	21.8	23.8	-23	
	1500	—	21.1	—	-25	
	2000	18.1	20.3	22.1	-28	
Reversed Isolation	30-2000		27		26	dB
Input Return Loss	30		11		12	dB
	500		12		12	
	1000		10		12	
	1500		11		15	
	2000		12		20	
Output Return Loss	30		15		2	dB
	500		14		2	
	1000		12		2	
	1500		10		2	
	2000		8		2	
Output Power @1dB compression AMP-ON	30		+26.2			dBm
	500		+27.9			
	1000		+28.5			
	1500		+28.1			
	2000		+27.7			
Output IP3 (Pout = 0dBm/Tone)	30	—	+39.6			dBm
	500	—	+41.6			
	1000	—	+42.6			
	1500	+38.2	+42.6			
	2000	—	+41.8			
Device Operating Voltage (VDD)		+7.6	+8	+8.4	+8	V
Device Operating Current (ID)			236	249	8	mA
Control Voltage (VG)			0		+5	V
DC Current (ID) Variation Vs. Temperature <sup>2</sup>			-225			uA/degC
DC Current (ID) Variation Vs. Voltage			0.0263			mA/mV
Thermal Resistance			23.3			degC/W

1. Measured on Mini-Circuits Characterization test board TB-TSS-23HLN+. See Characterization Test Circuit (Fig. 1)

2. (Current at 95°C – Current at -45°C)/140

## ABSOLUTE MAXIMUM RATINGS<sup>3</sup>

Parameter	Ratings
Operating Temperature (ground lead)	-40°C to 95°C
Storage Temperature	-65°C to 150°C
Total Power Dissipation	3.3 W
Input Power	+28 dBm (5 minutes max.) +15 dBm (continuous) for 0.03-1 GHz +18 dBm (continuous) for 1-2 GHz
DC Voltage V <sub>DD</sub> <sup>4</sup> (Pad 7)	+10 V
DC Voltage V <sub>G</sub> <sup>5</sup> (Pad 1)	+10 V

3 Permanent damage may occur if these limits are exceeded.

4 Measured by keeping VG=0V.

5 Measured by keeping Vdd=8V.

## CONTROL VOLTAGE (V<sub>G</sub>) FIG. 1

	Min.	Typ.	Max.	Units
Amplifier-ON	—	0	0.7	V
Amplifier-OFF	1.9	5	—	V





### SWITCHING SPECIFICATIONS

Parameter		Min.	Typ.	Max.	Units
Amplifier ON to Shutdown	OFF TIME (50% Control to 10% RF)	—	5.3	—	μs
	FALL TIME (90 to 10% RF)	—	7.3	—	
Amplifier Shutdown to ON	ON TIME (50% Control to 90% RF)	—	77.7	—	μs
	RISE TIME (10% to 90% RF)	—	54.2	—	
Control Voltage Leakage		—	633.3	—	mV

### SIMPLIFIED SCHEMATIC AND PAD DESCRIPTION

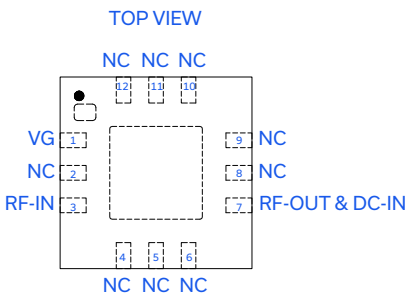
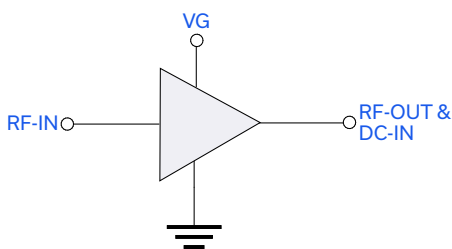

Function	Pad Number	Description
RF-IN	3	RF Input
RF-OUT and DC-IN	7	RF Output and DC Bias
GND	Paddle	Connections to ground.
NC	2, 4-6, 8-12	No connection, grounded externally
VG	1	Control voltage for shutdown (VG)



ULTRA HIGH DYNAMIC RANGE, SHUTDOWN

# Monolithic Amplifier

# TSS-23HLN+

## CHARACTERIZATION TEST CIRCUIT / RECOMMENDED APPLICATION CIRCUIT

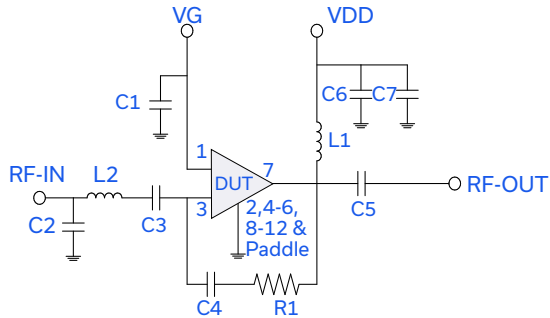

Component	Size	Value	Part Number	Manufacturer
C1	0402	0.1uF	GRM155R71C104KA88D	Murata
C2	0402	1.2pF	GRM1555C1H1R2CA1D	Murata
C3	0402	0.1uF	GRM155R71C104KA88D	Murata
C4	0402	0.1uF	GRM155R71C104KA88D	Murata
C5	0402	1000pF	GRM1555C1H102JA01D	Murata
C6	0402	10000pF	GRM155R71E103KA01D	Murata
C7	0402	0.1uF	GRM155R71C104KA88D	Murata
L1	0805	680nH	0805LS-681XJLB	Coilcraft
L2	0402	1.0nH	0402CS-1N0XJLW	Coilcraft
R1	0402	1.2KOhm	RK73H1ETTP1201F	Koa

Fig 1. Block diagram of Test Circuit used for characterization. (DUT soldered on Mini-Circuits Characterization test board TB-TSS-13LN+) Gain, Return loss, Output power at 1dB compression (P1dB) , output IP3 (OIP3) and noise figure measured using Agilent's N5242A PNA-X microwave network analyzer.

### Conditions:

- Gain and Return Loss:  $P_{IN} = -25$  dBm
- Output IP3 (OIP3): Two tones, spaced 1 MHz apart, +0dBm/tone at output.
- Switching Time  
 RF Signal:  $P_{IN} = -25$  dBm,  $f_{RF} = 500$  MHz.  
 $V_{DD} = +8V$  DC,  $V_G =$  Pulse signal at 1 KHz with  $V_{HIGH} = +5V$ ,  $V_{LOW} = 0V$ , 50% duty cycle.

## PRODUCT MARKING



Marking may contain other features or characters for internal lot control



ULTRA HIGH DYNAMIC RANGE, SHUTDOWN

# Monolithic Amplifier

## TSS-23HLN+

ADDITIONAL DETAILED TECHNICAL INFORMATION IS AVAILABLE ON OUR DASHBOARD. [CLICK HERE](#)

Performance Data	Data Table Swept Graphs S-Parameter (S2P Files) Data Set (.zip file)
Case Style	DQ1225 Plastic package, exposed paddle lead finish: Matte-Tin
Tape & Reel Standard quantities available on reel	F66 7" reels with 20, 50, 100, 200, 500, 1K, or 2K devices
Suggested Layout for PCB Design	PL-619
Evaluation Board	TB-TSS-23HLN+
Environmental Ratings	ENV08T9

### ESD RATING

Human Body Model (HBM): Class 1A (Pass 250 V) in accordance with ANSI/ESD STM 5.1 - 2001

### MSL FLOW CHART

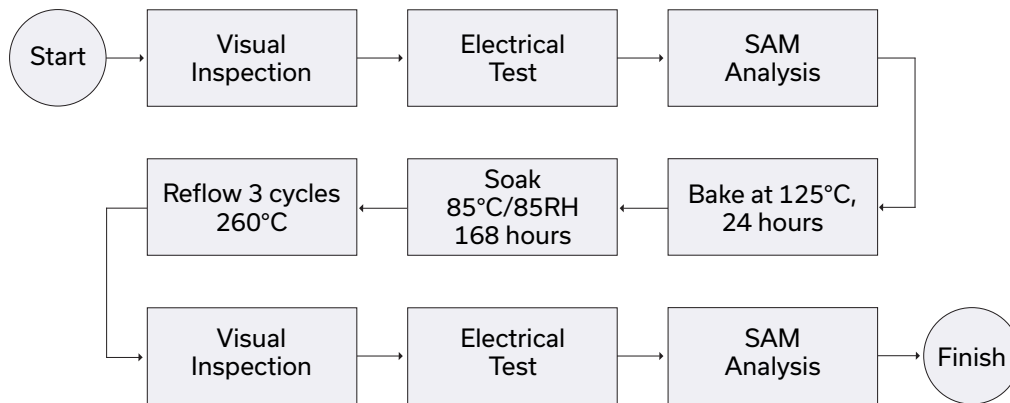

- NOTES**
- A. Performance and quality attributes and conditions not expressly stated in this specification document are intended to be excluded and do not form a part of this specification document.
  - B. Electrical specifications and performance data contained in this specification document are based on Mini-Circuit's applicable established test performance criteria and measurement instructions.
  - C. The parts covered by this specification document are subject to Mini-Circuits standard limited warranty and terms and conditions (collectively, "Standard Terms"); Purchasers of this part are entitled to the rights and benefits contained therein. For a full statement of the standard. Terms and the exclusive rights and remedies thereunder, please visit Mini-Circuits' website at [www.minicircuits.com/MCLStore/terms.jsp](http://www.minicircuits.com/MCLStore/terms.jsp)



# Mouser Electronics

Authorized Distributor

Click to View Pricing, Inventory, Delivery & Lifecycle Information:

[Mini-Circuits:](#)

[TSS-23HLN+](#)