

Ultra High Dynamic Range Monolithic Amplifier

PHA-23HLN+

50Ω 30MHz to 2 GHz

The Big Deal

- Ultra-High IP3, +44.4 dBm typ.
- Medium Power, +28.4dBm typ.
- Excellent Noise Figure, 1.4 dB typ.



SOT-89 PACKAGE

Product Overview

PHA-23HLN+ (RoHS compliant) is an advanced wideband amplifier fabricated using E-PHEMT technology and offers extremely high dynamic range over a broad frequency range and with low noise figure. In addition, the PHA-23HLN+ has good input and output return loss over a broad frequency range. PHA-23HLN+ is enclosed in a SOT-89 package and has very good thermal performance.

Key Features

Feature	Advantages
Broad Band: 30MHz to 2GHz	Broadband covering primary wireless communications bands: VHF, UHF, Cellular
Extremely High IP3 40.9 dBm typical at 30MHz 44.4 dBm typical at 1GHz	The PHA-23HLN+ matches industry leading IP3 performance relative to device size and power consumption. The combination of the design and E-PHEMT Structure provides enhanced linearity over a broad frequency range as evidence in the IP3 being approximately 14-17 dB above the P1dB point. This feature makes this amplifier ideal for use in: <ul style="list-style-type: none">• Driver amplifiers for complex waveform up converter paths• Drivers in linearized transmit systems• Secondary amplifiers in ultra-High Dynamic range receivers
Low Noise Figure 1.4 dB at 1 GHz	Enables lower system noise figure performance
High P1dB 28.4 dBm at 1 GHz	High P1dB, High OIP3, Low NF results in a very dynamic range preventing amplifier saturation under strong interfering signals. It can also be used to drive mixers requiring high drive

Notes

- A. Performance and quality attributes and conditions not expressly stated in this specification document are intended to be excluded and do not form a part of this specification document.
B. Electrical specifications and performance data contained in this specification document are based on Mini-Circuit's applicable established test performance criteria and measurement instructions.
C. The parts covered by this specification document are subject to Mini-Circuits standard limited warranty and terms and conditions (collectively, "Standard Terms"); Purchasers of this part are entitled to the rights and benefits contained therein. For a full statement of the Standard Terms and the exclusive rights and remedies thereunder, please visit Mini-Circuits' website at www.minicircuits.com/MCLStore/terms.jsp



Ultra High Dynamic Range Monolithic Amplifier

30MHz to 2 GHz

Product Features

- High IP3, 44.4 dBm typ. at 1GHz
- Gain, 21.3 dB typ. at 1 GHz
- High Pout, P1dB 28.4 dBm typ. at 1GHz
- Low noise figure, 1.4 dB at 1 GHz



Generic photo used for illustration purposes only

CASE STYLE: DF782

PHA-23HLN+

+RoHS Compliant

The +Suffix identifies RoHS Compliance. See our web site for RoHS Compliance methodologies and qualifications

Typical Applications

- Base station infrastructure
- CATV
- Cellular

General Description

PHA-23HLN+ (RoHS compliant) is an advanced wideband amplifier fabricated using E-PHEMT technology and offers extremely high dynamic range over a broad frequency range and with low noise figure. In addition, the PHA-23HLN+ has good input and output return loss over a broad frequency range. PHA-23HLN+ is enclosed in a SOT-89 package and has very good thermal performance.

simplified schematic and pin description

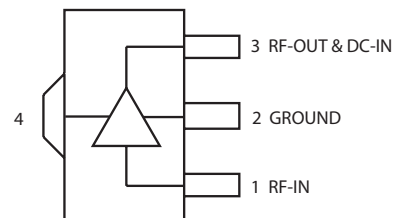
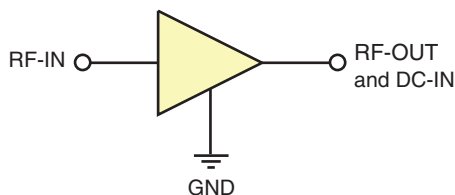

Function	Pin Number	Description
RF IN	1	RF Input
RF-OUT and DC-IN	3	RF Output and DC Bias
GND	2,4	Connections to ground.

Notes

- A. Performance and quality attributes and conditions not expressly stated in this specification document are intended to be excluded and do not form a part of this specification document.
 B. Electrical specifications and performance data contained in this specification document are based on Mini-Circuit's applicable established test performance criteria and measurement instructions.
 C. The parts covered by this specification document are subject to Mini-Circuits standard limited warranty and terms and conditions (collectively, "Standard Terms"); Purchasers of this part are entitled to the rights and benefits contained therein. For a full statement of the Standard Terms and the exclusive rights and remedies thereunder, please visit Mini-Circuits' website at www.minicircuits.com/MCLStore/terms.jsp



Electrical Specifications¹ at 25°C, 50Ω, unless noted

Parameter	Condition (MHz)	Vd=8V ¹			Units
		Min.	Typ.	Max.	
Frequency Range		30		2000	MHz
Gain	30	—	23.2	—	dB
	500	—	22.1	—	
	1000	19.2	21.3	23.5	
	1500	18.5	20.6	22.6	
	2000	—	19.5	—	
Input Return Loss	30		11.9		dB
	500		11.7		
	1000		9.9		
	1500		10.3		
	2000		9.5		
Output Return Loss	30		14.8		dB
	500		14.5		
	1000		14.2		
	1500		10.6		
	2000		8.2		
Reverse isolation	1000		27.5		dB
Output Power @1 dB compression	30		26.2		dBm
	500		28.1		
	1000		28.4		
	1500		28.0		
	2000		27.8		
Output IP3 ²	30		40.9		dBm
	500		43.6		
	1000		44.4		
	1500		45.8		
	2000		42.5		
Noise Figure	30		1.3		dB
	500		1.2		
	1000		1.4		
	1500		1.5		
	2000		1.9		
Device Operating Voltage			8.0		V
Device Operating Current			235	273	mA
Device Current Variation vs. Temperature ³			-209.8		μA/°C
Device Current Variation vs Voltage			0.0254		mA/mV
Thermal Resistance, junction-to-ground lead			23.3		°C/W
Junction-to-ground lead at 85°C stage temperature					

1. Measured on Mini-Circuits Characterization test board TB-951+. See Characterization Test Circuit (Fig. 1)

2. Tested at Pout= 0 dBm / tone.

3. (Current at 85°C — Current at -45°C)/130

Absolute Maximum Ratings⁴

Parameter	Ratings
Operating Temperature (ground lead)	-40°C to 95°C
Storage Temperature	-65°C to 150°C
Power Dissipation ⁵	3.3W
Input Power (CW)	+22 dBm (5 minutes max) ⁶ +11 dBm (continuous) for 0.03-1GHz +18 dBm (continuous) for 1-2 GHz
DC Voltage on Pin 3	10V

4. Permanent damage may occur if any of these limits are exceeded.

Electrical maximum ratings are not intended for continuous normal operation.

5. Up to 85°C, derate linearly to 3W at 95°C.

6. Up to 85°C, derate linearly to +19dBm at 95°C.

B. Electrical specifications and performance data contained in this specification document are based on Mini-Circuit's applicable established test performance criteria and measurement instructions.
C. The parts covered by this specification document are subject to Mini-Circuits standard limited warranty and terms and conditions (collectively, "Standard Terms"); Purchasers of this part are entitled to the rights and benefits contained therein. For a full statement of the Standard Terms and the exclusive rights and remedies thereunder, please visit Mini-Circuits' website at www.minicircuits.com/MCLStore/terms.jsp



Characterization Test / Recommended Application Circuit

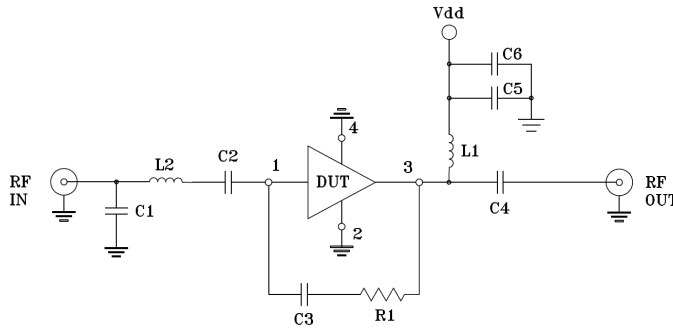

Component	Size	Value	Manufacturer	P/N
C1	0402	1.2pF	Murata	GRM1555C1H1R2WA01D
C2,C3,C6		0.1uF		GRM155R71C104KA88D
C4		0.001uF		GRM1555C1H102JA01D
C5		0.01uF		GRM155R71E103KA01D
R1		1.21KOhm	KOA	RK73H1ETTP1211F
L1	0805	0.68uH	Coilcraft	0805LS-681XJLB
L2	0402	1nH		0402CS-1N0XJLW

Fig 1. Block Diagram of Test Circuit used for characterization. (DUT soldered on Mini-Circuits Characterization test board TB-951+) Gain, Return loss, Output power at 1dB compression (P1dB), output IP3 (OIP3) and noise figure measured using Agilent’s N5242A PNA-X microwave network analyzer.

Conditions:

1. Gain and Return loss: Pin= -25dBm
2. Output IP3 (OIP3): Two tones, spaced 1 MHz apart, 0 dBm/ tone at output.

Product Marking

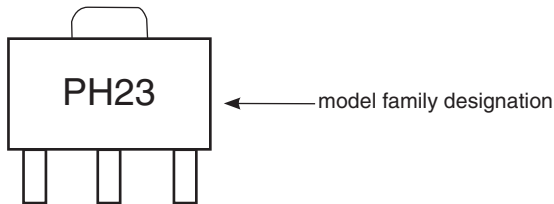

Marking may contain other features or characters for internal lot control

Notes

- A. Performance and quality attributes and conditions not expressly stated in this specification document are intended to be excluded and do not form a part of this specification document.
- B. Electrical specifications and performance data contained in this specification document are based on Mini-Circuit’s applicable established test performance criteria and measurement instructions.
- C. The parts covered by this specification document are subject to Mini-Circuits standard limited warranty and terms and conditions (collectively, “Standard Terms”); Purchasers of this part are entitled to the rights and benefits contained therein. For a full statement of the Standard Terms and the exclusive rights and remedies thereunder, please visit Mini-Circuits’ website at www.minicircuits.com/MCLStore/terms.jsp



Additional Detailed Technical Information	
additional information is available on our dash board. To access this information click here	
Performance Data	Data Table
	Swept Graphs
	S-Parameter (S2P Files) Data Set (.zip file)
Case Style	DF782 (SOT 89) <i>Plastic package, exposed paddle lead finish: Matte-Tin</i>
Tape & Reel Standard quantities available on reel	F55 <i>7" reels with 20, 50, 100, 200, 500 or 1K devices</i>
Suggested Layout for PCB Design	PL-512
Evaluation Board	TB-951+
Environmental Ratings	ENV08T9

ESD Rating

Human Body Model (HBM): Class 1B (Pass 500 V) in accordance with ANSI/ESD STM 5.1 - 2001

MSL Rating

Moisture Sensitivity: MSL1 in accordance with IPC/JEDEC J-STD-020D

MSL Test Flow Chart

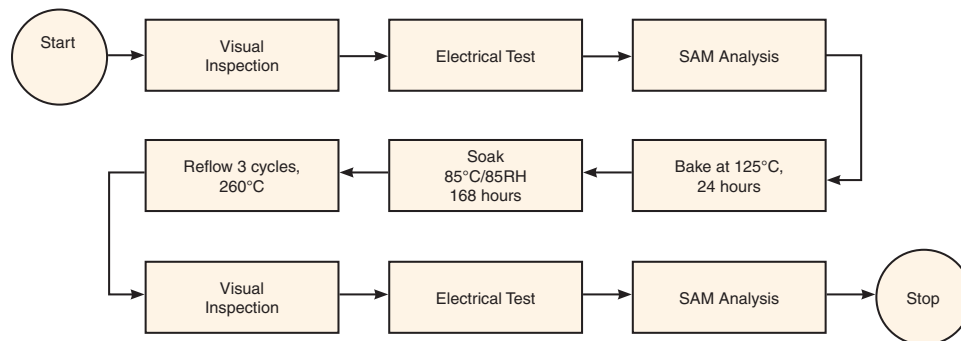

B. Electrical specifications and performance data contained in this specification document are based on Mini-Circuit's applicable established test performance criteria and measurement instructions.
 C. The parts covered by this specification document are subject to Mini-Circuits standard limited warranty and terms and conditions (collectively, "Standard Terms"); Purchasers of this part are entitled to the rights and benefits contained therein. For a full statement of the Standard Terms and the exclusive rights and remedies thereunder, please visit Mini-Circuits' website at www.minicircuits.com/MCLStore/terms.jsp

Mouser Electronics

Authorized Distributor

Click to View Pricing, Inventory, Delivery & Lifecycle Information:

[Mini-Circuits:](#)

[PHA-23HLN+](#)