



Please note that Cypress is an Infineon Technologies Company.

The document following this cover page is marked as “Cypress” document as this is the company that originally developed the product. Please note that Infineon will continue to offer the product to new and existing customers as part of the Infineon product portfolio.

Continuity of document content

The fact that Infineon offers the following product as part of the Infineon product portfolio does not lead to any changes to this document. Future revisions will occur when appropriate, and any changes will be set out on the document history page.

Continuity of ordering part numbers

Infineon continues to support existing part numbers. Please continue to use the ordering part numbers listed in the datasheet for ordering.

Bluetooth Low Energy System in Package (SiP) Module

The Cypress CYW20737L is a compact, highly integrated Bluetooth Low Energy (BLE) system-in-package (SiP) module. The device includes an embedded BLE antenna, 24 MHz clock, and 512 Kb EEPROM, so a minimal set of external components is needed to create a standalone BLE device.

The CYW20737L accelerates time to market. The Bluetooth stack and several application profiles are built into the module, allowing customers to focus on their core applications. To further reduce application development time, the CYW20737L includes integrated software support, with one-click installation of the complete environment and a one-click compile/build/link/load cycle. Coupled with an ultrasmall form factor and support for a wide voltage range, the CYW20737L is ideal for any BT Smart application.

Cypress Part Numbering Scheme

Cypress is converting the acquired IoT part numbers from Broadcom to the Cypress part numbering scheme. Due to this conversion, there is no change in form, fit, or function as a result of offering the device with Cypress part number marking. The table provides Cypress ordering part number that matches an existing IoT part number.

Table 1. Mapping Table for Part Number between Broadcom and Cypress

Broadcom Part Number	Cypress Part Number
BCM20737L	CYW20737L

Features

- ARM Cortex-M3 microcontroller unit (MCU)
- Embedded 512 Kb EEPROM
- Broadcom Serial Control (BSC), SPI, and UART interfaces
- FCC and CE compliant
- RoHS compliant, certified lead- and halogen-free
- Moisture Sensitivity Level (MSL) 3 compliant
- 6.5 mm × 6.5 mm × 1.2 mm Land Grid Array (LGA) 48-pin package
- Requires external 1.2V DC-DC for low power in sleep and active modes.

Applications

Profiles supported in ROM:

- Battery status
- Blood pressure monitor
- Find me
- Heart rate monitor
- Proximity
- Thermometer and Weight scale
- Time
- Blood glucose monitor
- Support for RSA security library
- Support for LE Audio
- Support for pairing using NFC tags

Additional profiles supported in RAM:

- Blood glucose monitor
- Temperature alarm
- Location
- Other custom profiles

Figure 1. CYW20737L BLE SiP Block Diagram

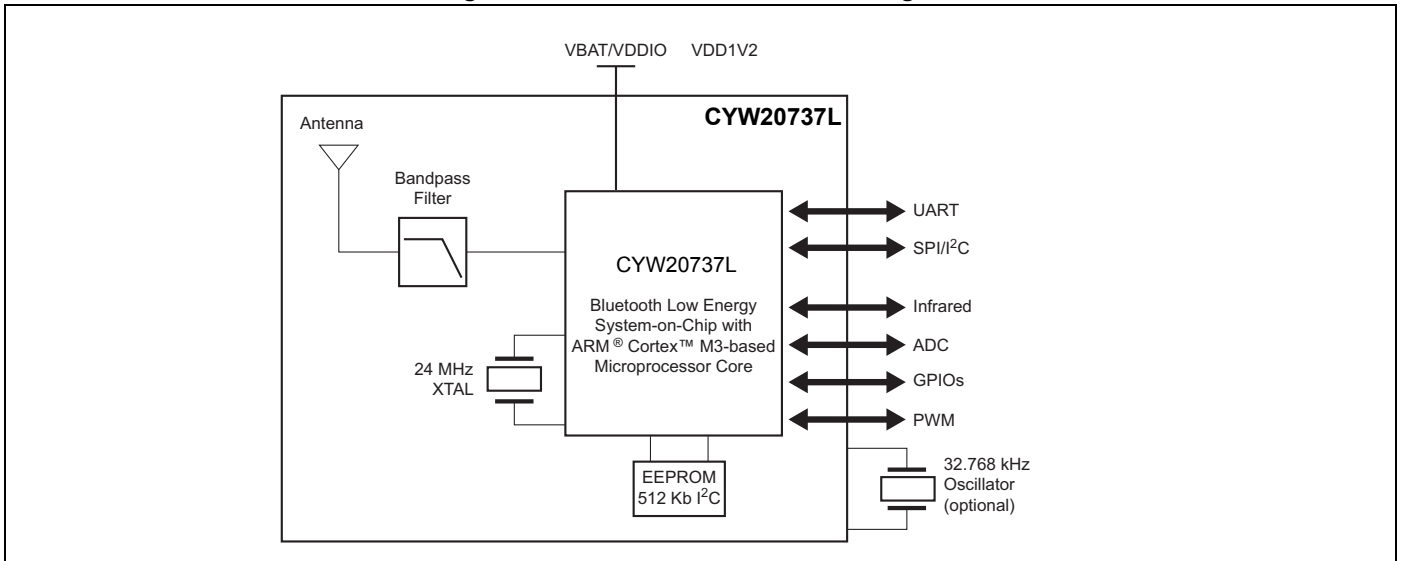

IoT Resources

Cypress provides a wealth of data at <http://www.cypress.com/internet-things-iot> to help you to select the right IoT device for your design, and quickly and effectively integrate the device into your design. Cypress provides customer access to a wide range of information, including technical documentation, schematic diagrams, product bill of materials, PCB layout information, and software updates. Customers can acquire technical documentation and software from the Cypress Support Community website (<http://community.cypress.com/>).

Contents

1. Functional Description	4	6.3 UART Timing.....	15
1.1 External Reset.....	4	7. PCB Design and Manufacturing Recommendations	16
1.2 32.768 kHz Oscillator	4	7.1 Pad and Solder Mask Opening Dimensions.....	16
1.3 External DC-DC Switcher Characteristics	4	7.2 PCB Layout Recommendations	16
2. Pin Map and Signal Descriptions	5	7.3 PCB Stencil	17
3. Electrical Specifications	10	7.4 Solder Reflow	17
4. RF Specifications	11	8. Packaging and Storage Information	18
5. ADC Specifications	12	9. Mechanical Information	20
6. Timing and AC Characteristics	13	10. Ordering Information	22
6.1 SPI Timing.....	13	Document History	23
6.2 BSC Interface Timing	14		

1. Functional Description

1.1 External Reset

External reset timing for the CYW20737L is illustrated in Figure 2.

Figure 2. External Reset Timing

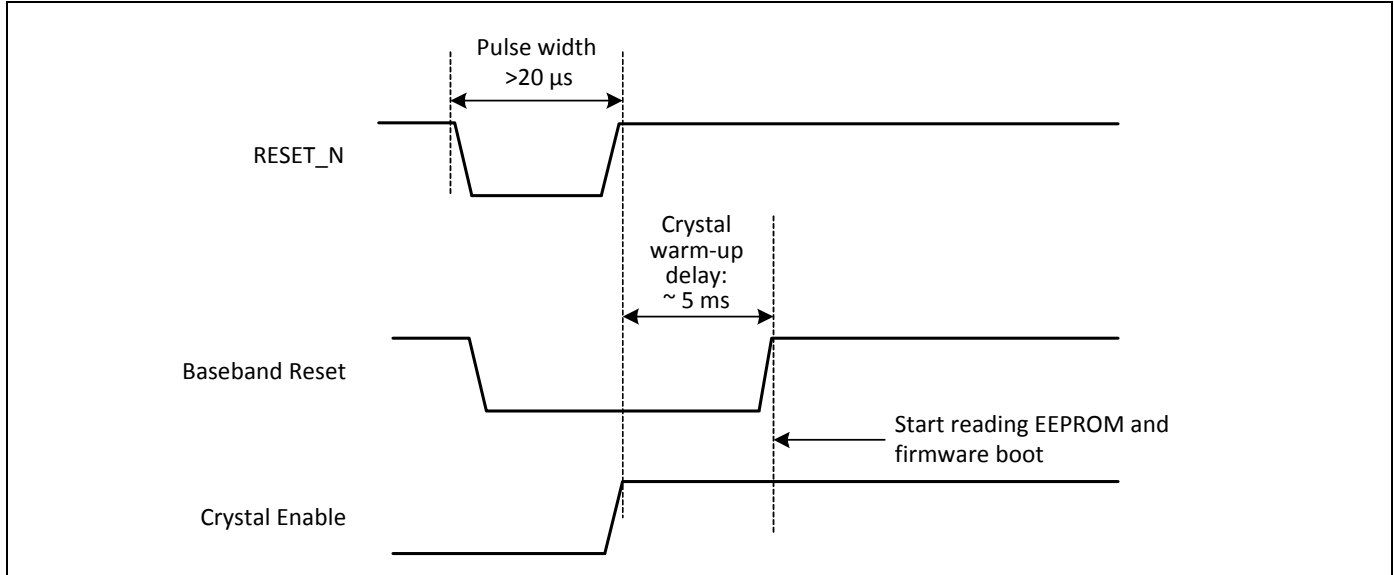

1.2 32.768 kHz Oscillator

The CYW20737L includes a standard Pierce oscillator. The oscillator circuit includes a comparator with hysteresis on the output to create a single-ended digital output. The hysteresis eliminates chatter when the input is near the comparator threshold (~100 mV). The oscillator circuit can be designed for a 32 kHz or 32.768 kHz crystal oscillator, and can also be driven by an external clock input with a similar frequency. Characteristics for a 32 kHz oscillator are defined in Table 2.

Table 2. 32 kHz Crystal Oscillator Characteristics

Parameter	Symbol	Conditions	Min.	Typ.	Max.	Unit
Output frequency	F_{oscout}	–	–	32.768	–	kHz
Frequency tolerance	F_{tol}	Crystal-dependent	–	100	–	ppm
Start-up time	T_{startup}	–	–	–	500	μs
Crystal drive level	P_{drv}	For crystal selection	0.5	–	–	μW
Crystal series resistance	R_{series}	For crystal selection	–	–	70	k Ω
Crystal shunt capacitance	C_{shunt}	For crystal selection	–	–	1.3	pF

1.3 External DC-DC Switcher Characteristics

The CYW20737L requires an external 1.2V DC switcher to operate its internal digital and RF circuits. A suitable low-power, low-noise switcher must be supplied for proper circuit operation. Digital and analog I/Os, as well as the internal EEPROM operation from the VBAT/VDDIO, can be from 1.62V to 3.63V. The recommended setting is 3V nominal voltage.

The following switcher, from Torex Semiconductor LTD, has been qualified and is recommended for all designs.

- XC9265B/D (see <http://www.torexsemi.com/products/detail.php?id=623>)

2. Pin Map and Signal Descriptions

The CYW20737L pin map is shown in [Figure 3](#).

Figure 3. CYW20737L (TOP View)

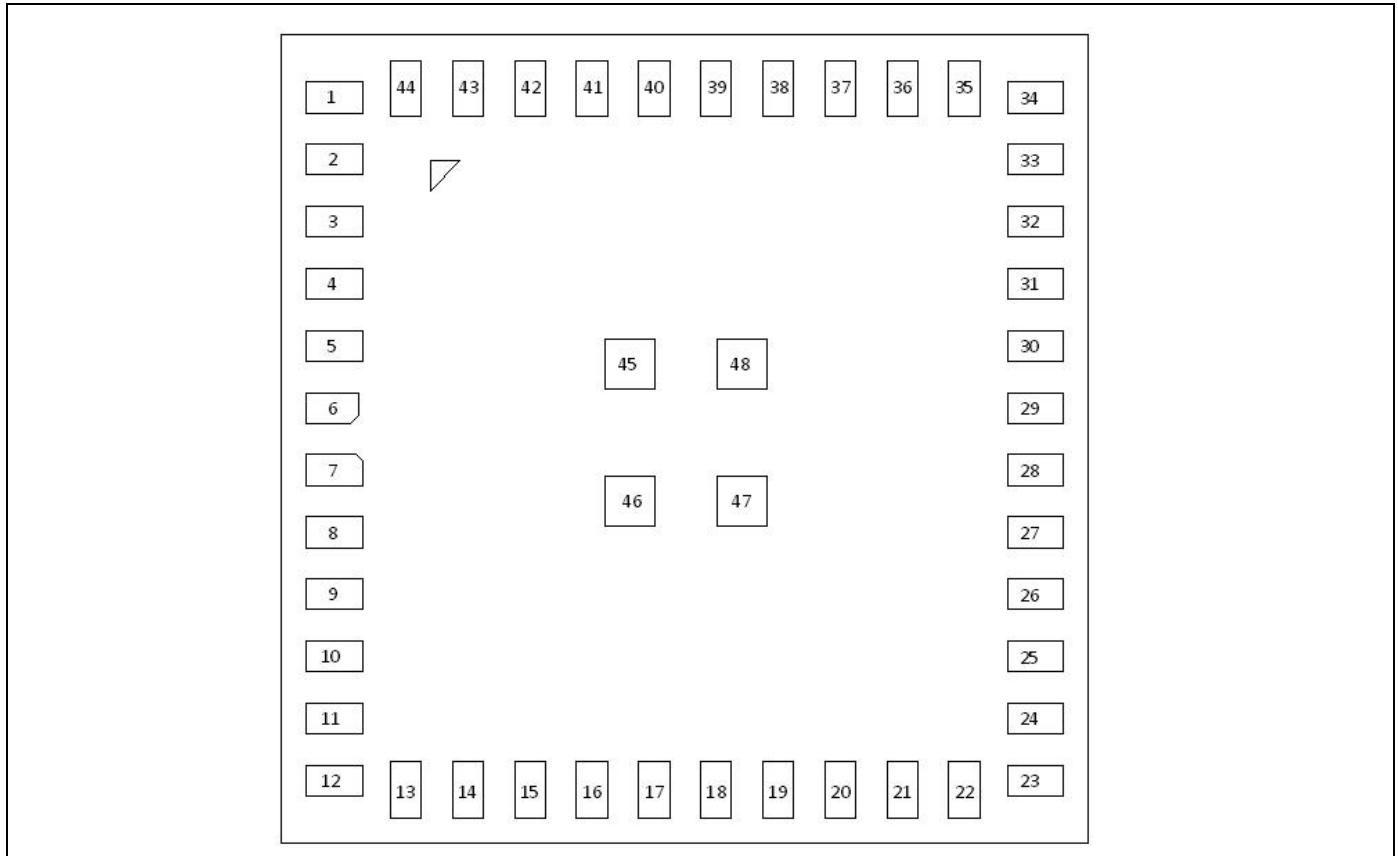

The signal name, type, and description of each pin in the CYW20737L is listed in [Table 3 on page 6](#). The symbols shown under I/O Type indicate pin directions (I/O = bidirectional, I = input, O = output) and the internal pull-up/pull-down characteristics (PU = weak internal pull-up resistor and PD = weak internal pull-down resistor), if any.

Table 3. Pin Descriptions

Pin	Name	I/O Type	Description
1	GPIO: P27 PWM1	I	Default direction: Input. After POR state: Input floating. Drain current: 16 mA Alternate function: MOSI (master and slave) for SPI_2
2	GND	GND	GND
3	VBAT	I	Battery supply input.
4	GND	GND	GND
5	GND	GND	GND
6	GND	GND	GND
7	GND	GND	GND
8	GND	GND	GND
9	GND	GND	GND
10	Reserved	–	Leave floating
11	GND	GND	GND
12	GND	GND	GND
13	GND	GND	GND
14	GND	GND	GND
15	GND	GND	GND
16	VDDC	I	Connects to the 1.2V DC-DC step down switcher input. Note: The HIDEOFF/Deep Sleep function is not available when the external DC-DC is used.
17	GND	GND	GND
18	UART_RX	I	UART_RX. This pin is pulled low through an internal 10 kΩ resistor.
19	UART_TX	O, PU	UART_TX
20	GND	GND	GND
21	SCL	I/O, PU	SCL I/O, PU clock signal for an external I ² C device
22	SDA	I/O, PU	SDA I/O, PU data signal for an external I ² C device
23	GND	GND	GND
24	GND	GND	GND
25	GPIO: P1	I	Default direction: Input. After POR state: Input floating. This pin is tied to the WP pin of the embedded EEPROM. Requires an external 10K pull-up
26	TMC	I	Test mode control. Pull this pin high to invoke test mode; leave it floating if not used. This pin is connected to GND through an internal 10 kΩ resistor.
27	RESET_N	I/O PU	Active-low system reset with open-drain output

Table 3. Pin Descriptions (Cont.)

Pin	Name	I/O Type	Description
28	GPIO: P0	I	<p>Default direction: Input. After POR state: Input floating. Alternate functions:</p> <ul style="list-style-type: none"> ■ A/D converter input ■ Peripheral UART TX (PUART_TX) ■ MOSI (master and slave) for SPI_2 ■ IR_RX ■ 60Hz_main
29	GND	GND	GND
30	GPIO: P3	I	<p>Default direction: Input. After POR state: Input floating. Alternate functions:</p> <ul style="list-style-type: none"> ■ Peripheral UART CTS (PUART_CTS) ■ SPI_CLK (master and slave) for SPI_2
31	GPIO: P2	I	<p>Default direction: Input. After POR state: Input floating. Alternate functions:</p> <ul style="list-style-type: none"> ■ Peripheral UART RX (PUART_RX) ■ SPI_CS (slave only) for SPI_2 ■ SPI_MOSI (master only) for SPI_2
32	GPIO: P4	I	<p>Default direction: Input. After POR state: Input floating. Alternate functions:</p> <ul style="list-style-type: none"> ■ Peripheral UART RX (PUART_RX) ■ MOSI (master and slave) for SPI_2. ■ IR_TX
33	GPIO: P8	I	<p>Default direction: Input. After POR state: Input floating. Alternate functions: A/D converter input.</p>
34	GPIO: P33	I	<p>Default direction: Input. After POR state: Input floating. Alternate functions:</p> <ul style="list-style-type: none"> ■ A/D converter input ■ MOSI (slave only) for SPI_2 ■ Auxiliary clock output (ACLK1) ■ Peripheral UART RX (PUART_RX)

Table 3. Pin Descriptions (Cont.)

Pin	Name	I/O Type	Description
35	GPIO: P32	I	Default direction: Input. After POR state: Input floating. Alternate functions: <ul style="list-style-type: none"> ■ A/D converter input ■ SPI_CS (slave only) for SPI_2. ■ Auxiliary clock output (ACLK0) ■ Peripheral UART TX (PUART_TX)
36	GPIO: P25	I	Default direction: Input. After POR state: Input floating. Alternate functions: <ul style="list-style-type: none"> ■ MISO (master and slave) for SPI_2 ■ Peripheral UART RX (PUART_RX)
37	GPIO: P24	I	Default direction: Input. After POR state: Input floating. Alternate functions: <ul style="list-style-type: none"> ■ SPI_CLK (master and slave) for SPI_2 ■ Peripheral UART TX (PUART_TX)
38	NC	NC	No Connection (N/C).
39	GPIO: P13 PWM3	I	Default Direction: Input After POR State: Input Floating Drain current: 16 mA Alternate function: A/D converter input
	GPIO: P28 PWM2	I	Default direction: Input. After POR state: Input floating. Drain current: 16 mA Alternate functions: <ul style="list-style-type: none"> ■ A/D converter input ■ LED1 ■ IR_TX
40	GPIO: P14 PWM2	I	Default direction: Input. After POR state: Input floating. Alternate function: A/D converter input
	GPIO: P38	I	Default direction: Input. After POR state: Input floating. Alternate functions: <ul style="list-style-type: none"> ■ A/D converter input ■ MOSI (master and slave) for SPI_2 ■ IR_TX
41	GPIO: P15	I	Default direction: Input. After POR state: Input floating. Alternate functions: <ul style="list-style-type: none"> ■ A/D converter input ■ IR_RX ■ 60 Hz_main

Table 3. Pin Descriptions (Cont.)

Pin	Name	I/O Type	Description
42	GPIO: P26 PWM0	I	Default direction: Input. After POR state: Input floating. Drain current: 16 mA Alternate function: SPI_CS (slave only) for SPI_2
43	GPIO: P12	I	Default direction: Input. After POR state: Input floating. Alternate functions: ■ A/D converter input ■ XTALO32K
	XTALO32K	O	Low-power oscillator (LPO) output. Alternate functions: P12 P26
44	GPIO: P11	I	Default direction: Input. After POR state: Input floating. Alternate functions: ■ A/D converter input ■ XTALI32K
	XTALI32K	I	Low-power oscillator (LPO) input. Alternate functions: ■ P11 ■ P27
45	GND	GND	GND
46	GND	GND	GND
47	GND	GND	GND
48	GND	GND	GND

3. Electrical Specifications

Absolute maximum ratings are defined in [Table 4](#).

Table 4. Absolute Maximum Ratings

Parameter	Min.	Max.	Unit
Supply power	NA	1.32	V
Storage temperature	-40	125	°C
Voltage ripple	0	±2	%
Power supply (VBAT absolute maximum rating)	1.62	3.63	V

Power for the CYW20737L module is provided by the system through the power pins.

Table 5. Voltage

Symbol	Parameter	Min.	Typ.	Max.	Unit
VBAT	Battery voltage	1.62	-	3.63	V

Table 6. Current Consumption

Operating Mode	Condition	Nominal	Maximum	Unit
Receive	Receiver and baseband are both operating, 100%	11.5	12.4	mA
Transmit	Transmitter and baseband are both operating, 100%	9.0	9.8	mA
Sleep	Wake in < 5 ms	29.0	35.0	µA

Note: All measurements taken at 25°C

4. RF Specifications

CYW20737L receiver specifications are defined in [Table 7](#).

Table 7. Receiver Specifications

Parameter	Mode and Conditions	Min.	Typ.	Max.	Unit
Frequency range	–	2402	–	2480	MHz
RX sensitivity (standard)	Packets: 200 Payload: PRBS 9 Length: 37 Bytes Dirty Transmitter: off. PER: 30.8%	–	–94	–	dBm
Maximum input	–	–10	–	–	dBm

Note: All measurements taken at 25°C

RF transmitter specifications are defined in [Table 8](#).

Table 8. Transmitter Specifications

Parameter	Min.	Typ.	Max.	Unit
Transmitter				
Frequency range ^a	2402	–	2480	MHz
Output power adjustment range	–20	–	4	dBm
Output power	–	2	–	dBm
Output power variation	–	2.5	–	dB
LO Performance				
Initial carrier frequency tolerance	–	–	±150	kHz
Frequency Drift				
Frequency drift	–	–	±50	kHz
Drift rate	–	–	20	kHz/50 μs
Frequency Deviation				
Average deviation in payload (sequence: 00001111)	225	–	275	kHz
Average deviation in payload (sequence: 10101010)	185	–	–	kHz
Channel spacing	–	2	–	MHz

a. This parameter is taken from the Bluetooth 4.0 specification.

5. ADC Specifications

CYW20737L ADC specifications are defined in [Table 9](#).

Table 9. ADC Specifications

Parameter	Symbol	Conditions	Min.	Typ.	Max.	Unit
Number of input channels	–	–	–	9	–	–
Channel switching rate	f_{ch}	–	–	–	133.33	Kch/s
Input signal range	V_{inp}	–	0	–	3.63	V
Reference settling time	–	Charging refsel	7.5	–	–	μ s
Input resistance	R_{inp}	Effective, single-ended	–	500	–	k Ω
Input capacitance	C_{inp}	–	–	–	5	pF
Conversion rate	F_c	–	5.859	–	187	kHz
Conversion time	T_c	–	5.35	–	170.7	μ s
Resolution	R	–	–	16	–	Bits
Absolute voltage measurement error	–	Using on–chip ADC firmware driver	–	± 2	–	%
Current	I	$I_{avdd1p2} + I_{avdd3p3}$	–	–	1	mA
Power	P	–	–	1.5	–	mW
Leakage Current	$I_{leakage}$	T = 25°C	–	–	100	nA
Power-up time	$T_{powerup}$	–	–	–	200	μ s
Integral nonlinearity	I_{NL}	In the guaranteed performance range	–1	–	1	LSB ^a
Differential nonlinearity	D_{NL}	In the guaranteed performance range	–1	–	1	LSB ^a

a. LSBs are expressed at the 10-bit level.

6. Timing and AC Characteristics

6.1 SPI Timing

SPI interface timing is illustrated in [Figure 4](#) and [Figure 5](#) and defined in [Table 10](#) on page 14.

Figure 4. SPI Timing—Modes 0 and 2

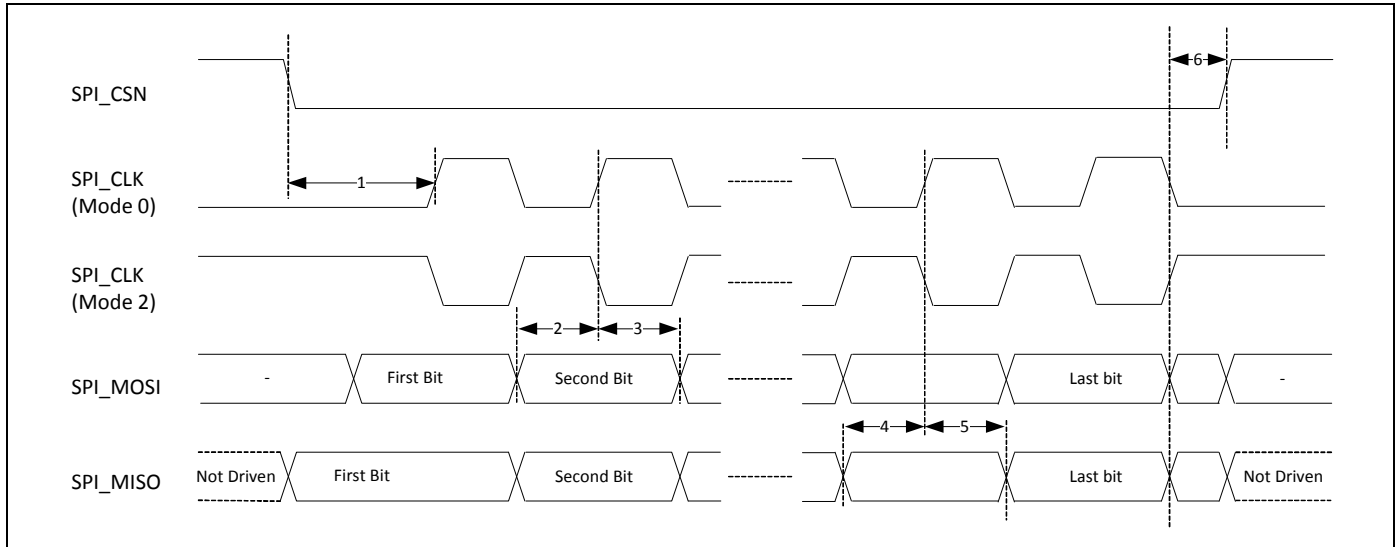

Figure 5. SPI Timing—Modes 1 and 3

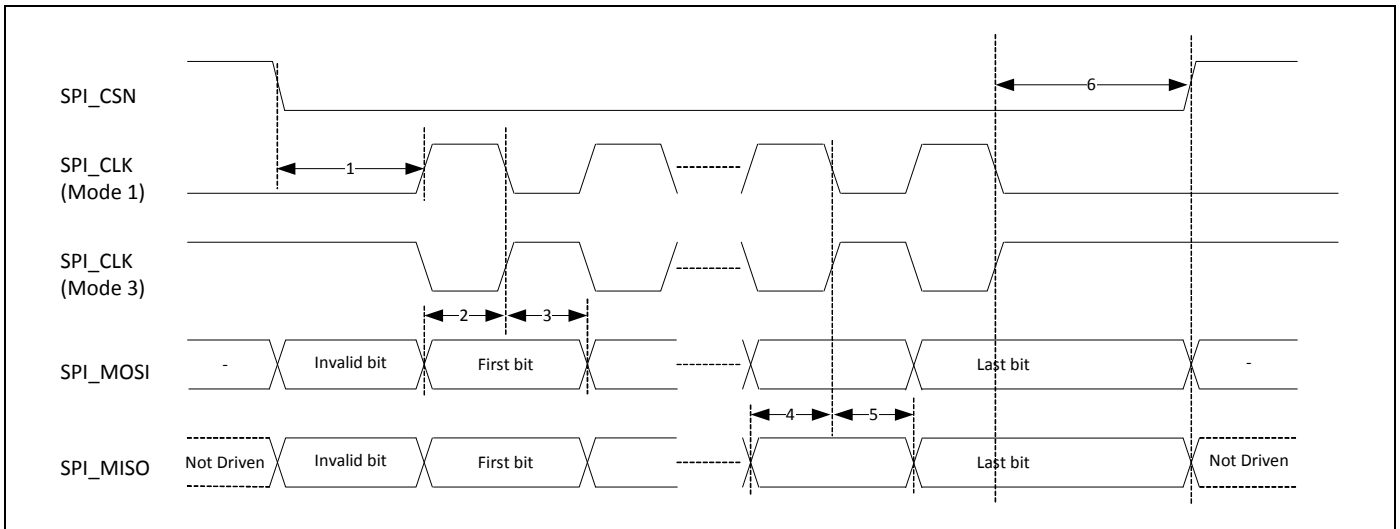

Table 10. SPI Interface Timing Specifications

Reference	Characteristics	Min.	Typ.	Max.
1	Time from CSN asserted to first clock edge	1 SCK	100	∞
2	Master setup time	–	1/2SCK	–
3	Master hold time	1/2SCK	-	–
4	Slave setup time	–	1/2 SCK	–
5	Slave hold time	1/2 SCK	–	–
6	Time from last clock edge to CSN deasserted	SCK	10 SCK	100

6.2 BSC Interface Timing

BSC interface timing is illustrated in [Figure 6](#) and is defined in [Table 11](#).

Figure 6. BSC Interface Timing

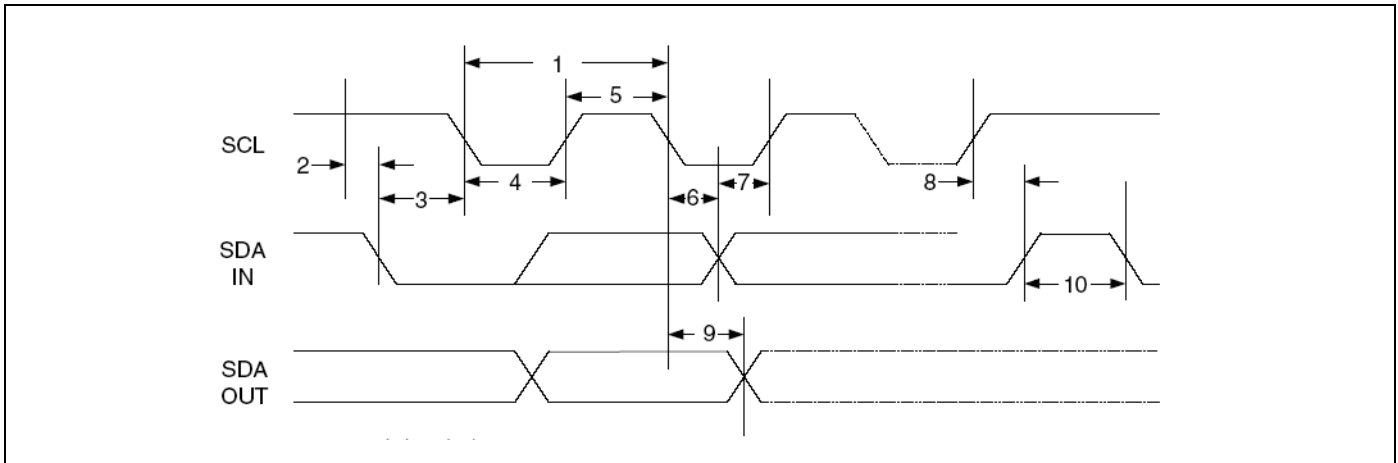

Table 11. BSC Interface Timing Specifications

Reference	Characteristics	Min.	Max.	Unit
1	Clock frequency	–	100, 400, 800, 1000	kHz
2	START condition setup time	650	–	ns
3	START condition hold time	280	–	ns
4	Clock low time	650	–	ns
5	Clock high time	280	–	ns
6	Data input hold time	0	–	ns
7	Data input setup time	100	–	ns
8	STOP condition setup time	280	–	ns
9	Output valid from clock	–	400	ns
10	Bus free time	650	–	ns

6.3 UART Timing

UART timing is illustrated in Figure 7 and defined in Table 12.

Figure 7. UART Timing

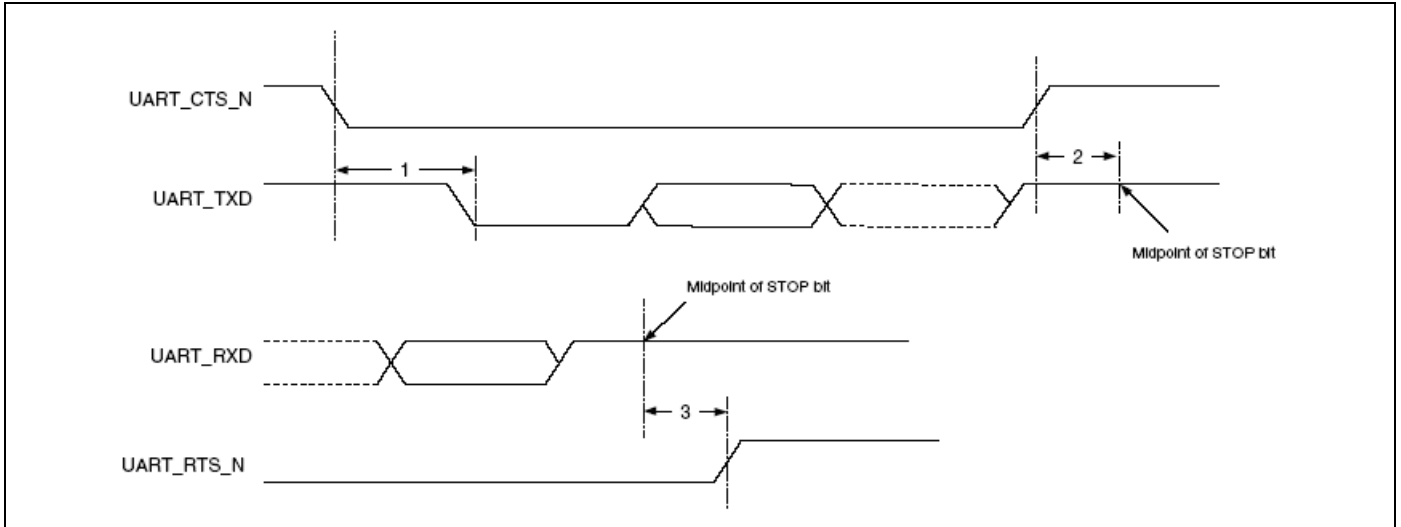

Table 12. UART Timing Specifications

Reference	Characteristics	Min.	Max.	Unit
1	Delay time, UART_CTS_N low to UART_TXD valid	–	24	Baudout cycles
2	Setup time, UART_CTS_N high before midpoint of stop bit	–	10	ns
3	Delay time, midpoint of stop bit to UART_RTS_N high	–	2	Baudout cycles

7. PCB Design and Manufacturing Recommendations

7.1 Pad and Solder Mask Opening Dimensions

CYW20737L pad and solder mask opening dimensions are defined in [Table 13](#).

Table 13. Pad and Solder Mask Dimensions

Pad Type	Pad Dimensions	Solder Mask Opening Dimensions	Unit
Type A	0.6 × 0.25	0.7 × 0.35	mm
Type B	0.55 × 0.3	0.65 × 0.4	
Type C	0.4 × 0.4	0.5 × 0.5	

7.2 PCB Layout Recommendations

The following layout recommendations are referenced to [Figure 8 on page 16](#).

- Connect to system ground from side D of the module (pins 13–22).
- The L-shaped ground plane is required for the embedded BLE antenna. Keep the GND continuous. Do not cut off the GND shape to accommodate trace routes.
- An L-shaped ground plane is required. If the L-shaped GND plane is located on the top layer of the PCB, do not place components on the ground plane. If this cannot be avoided, move the L-shaped ground plane to another layer.
- Antenna efficiency of 31–41% can be achieved based on the layout in [Figure 8 on page 16](#) and the dimensions listed below. Following these layout recommendations is expected to yield 50+ meters of usable range; deviating from these recommendations may reduce the range of the antenna.
 - D: 4.5 mm (typical)
 - G, H, S: 3 mm (typical)
 - L: 3 mm (minimum)
 - W: 0.4 mm (typical)
- Route signal traces out of the module from side C (between pins 27 and 30) or side D (between pins 16 and 19) of the module. Traces can be overlapped to avoid routing through the keep-out area.
- Do not route traces from side A or side B.

Figure 8. PCB Layout Example

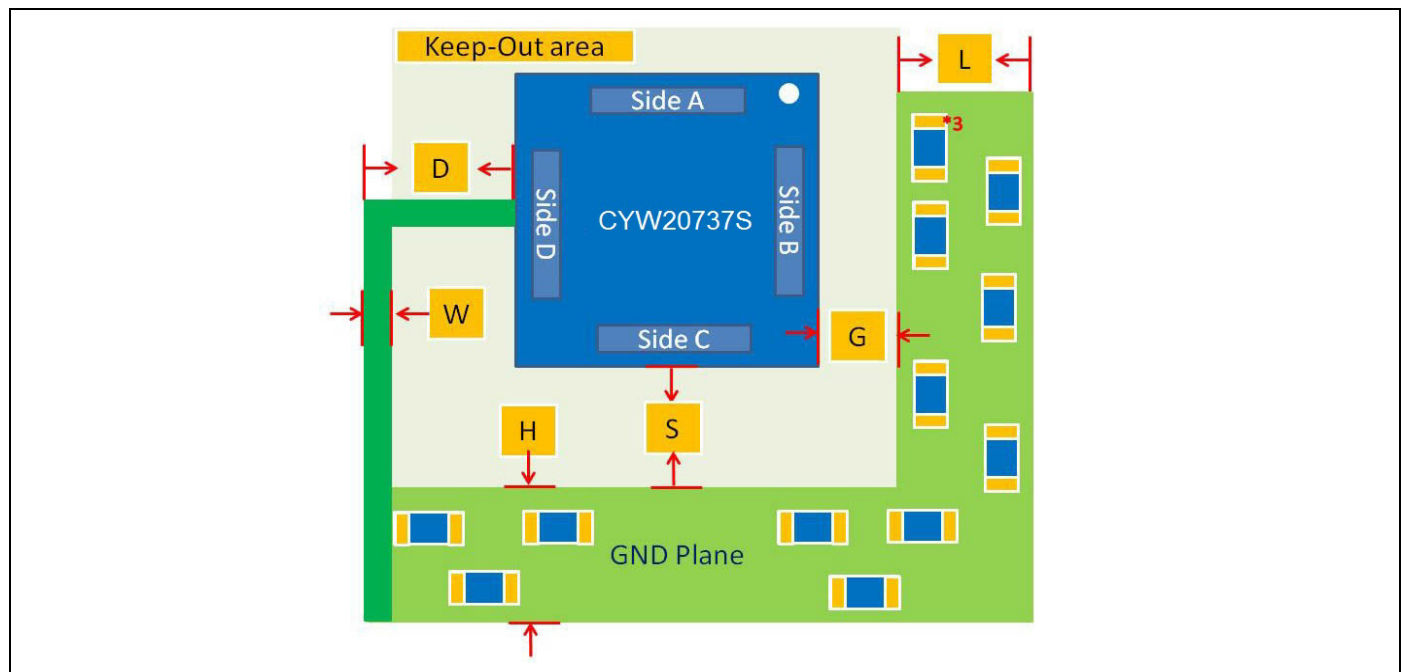

7.3 PCB Stencil

The recommended PCB stencil is shown in [Figure 9](#) (all measurements in mm). Use an unsolder mask to set the module footprint.

Figure 9. CYW20737L Stencil (Bottom View)

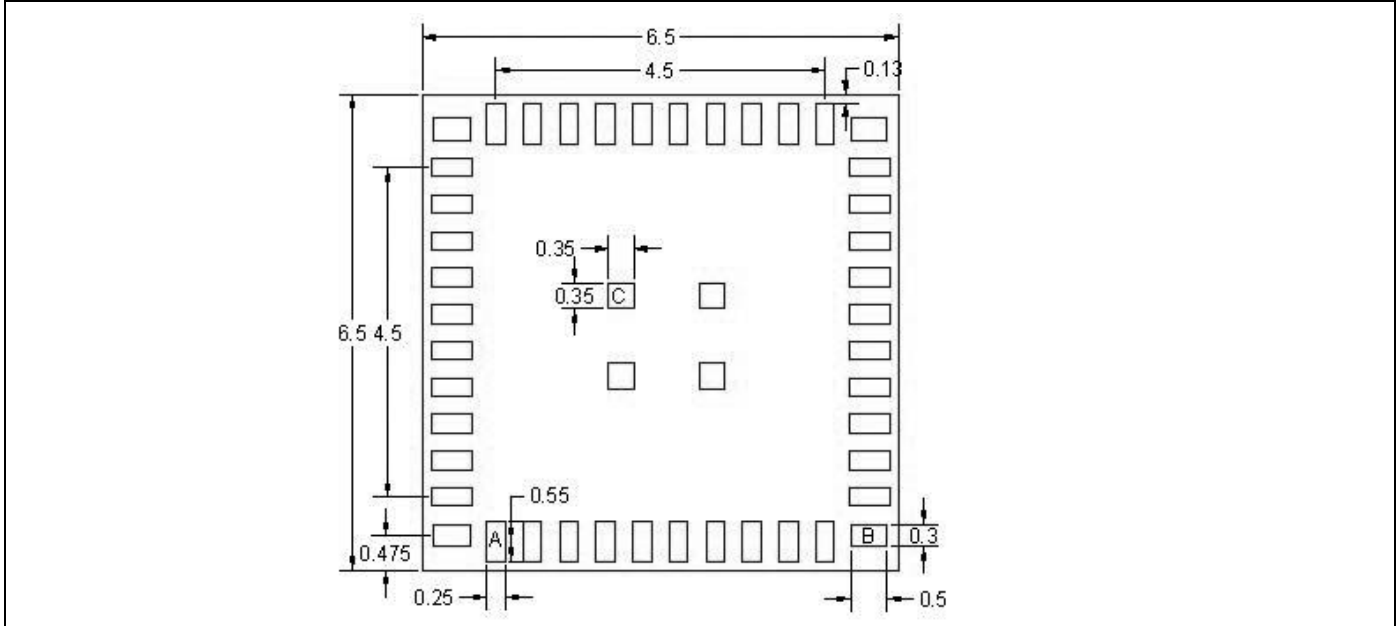

7.4 Solder Reflow

The recommended solder reflow profile for the CYW20737L is defined in [Figure 10](#).

Figure 10. Solder Reflow Profile

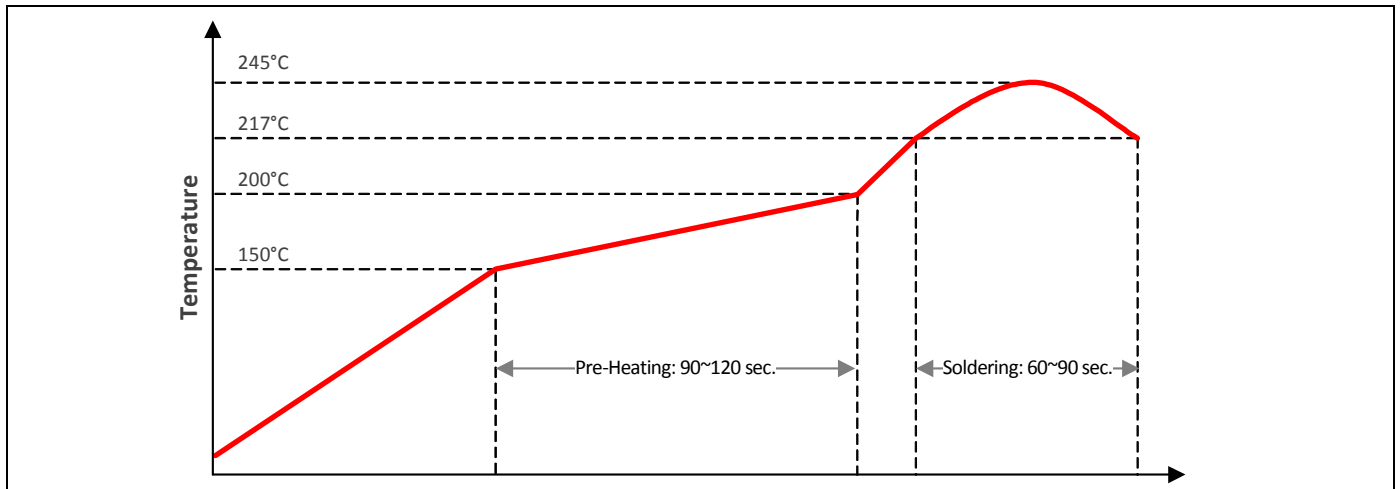

8. Packaging and Storage Information

The CYW20737L is available in a tape and reel package and is shipped in an ESD-protected moisture-resistant (MSL-3) bag as shown in [Figure 11](#). The storage temperature range is -40°C to $+125^{\circ}\text{C}$.

Figure 11. CYW20737L ESD/Moisture Packaging



The moisture sensitivity label on the CYW20737L shipping bag is shown in [Figure 12](#) on page 19.

Figure 12. CYW20737L Moisture Sensitivity Label

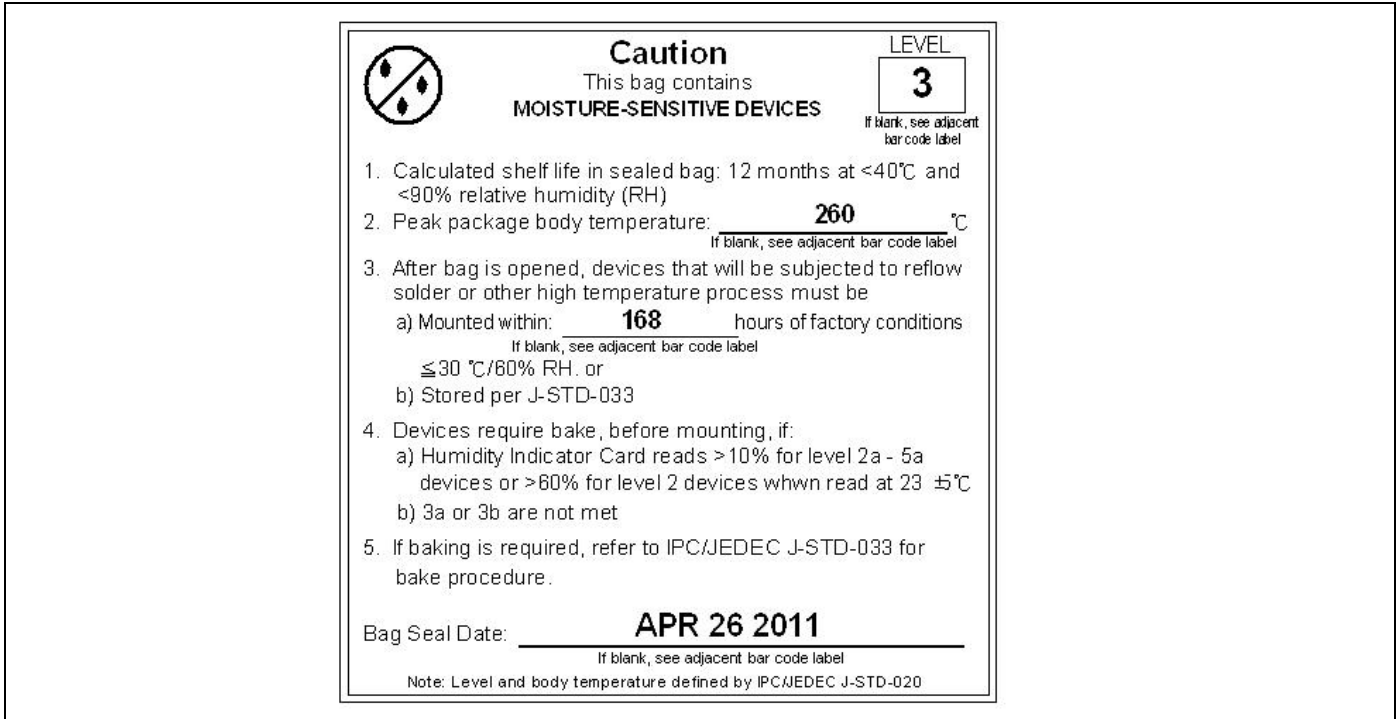
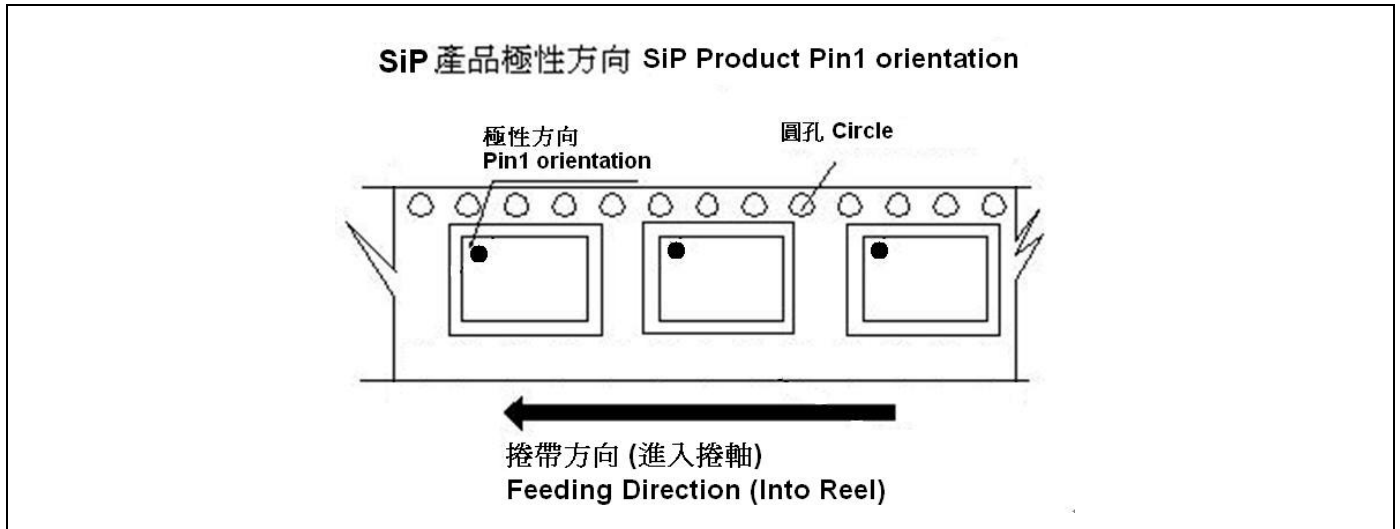

Figure 13 shows the location of pin 1 on the CYW20737L relative to its orientation on the tape packaging.

Figure 13. CYW20737L Tape and Reel Pin 1 Location



9. Mechanical Information

Package dimensions for the CYW20737L are shown in Figure 14.

Figure 14. CYW20737L Package Dimensions

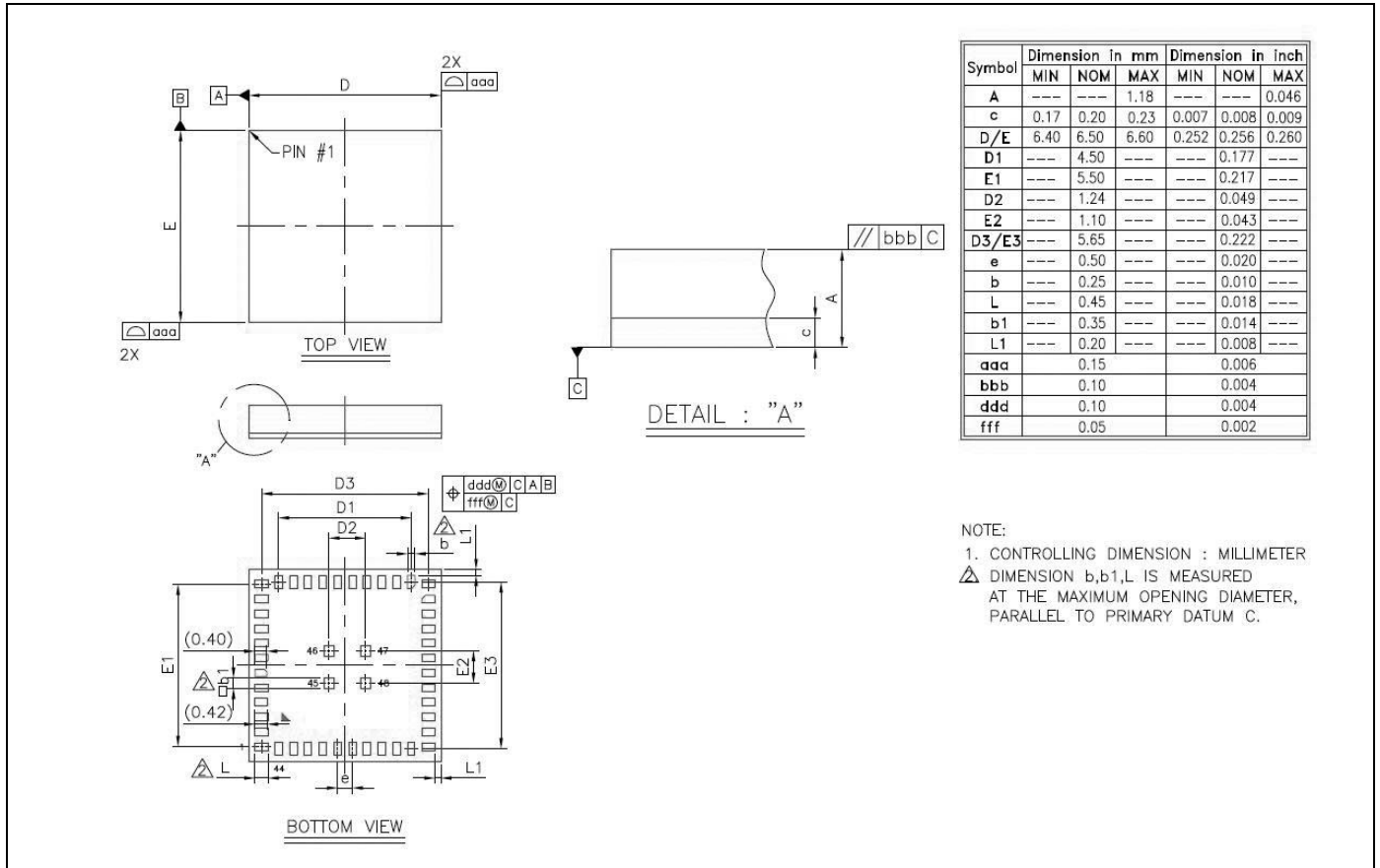

Additional CYW20737L package dimensions are shown in Figure 15.

Figure 15. CYW20737L Pin Dimensions (Bottom View)

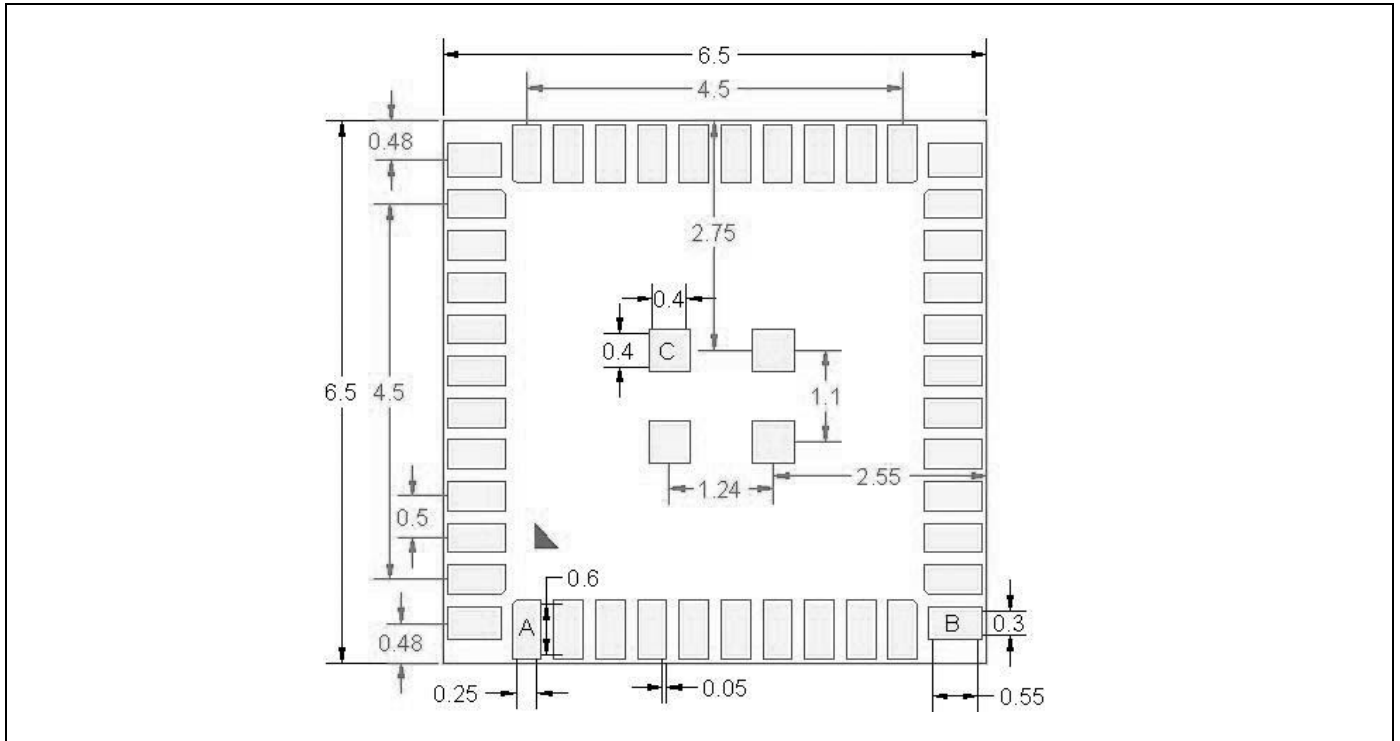

10. Ordering Information

Table 14. Ordering Information

Part Number	Package	Operating Temperature	Humidity
CYW20737L	48-pin LGA	-40°C to +85°C	95% max., noncondensing

Document History

Document Title: CYW20737L Bluetooth Low Energy System in Package (SiP) Module				
Document Number: 002-14886				
Revision	ECN	Orig. of Change	Submission Date	Description of Change
**	-	-	03/01/2016	20737L-DS100-R: Initial release
*A	-	UTSV	03/24/2016	20737L-DS101-R: Updated: <ul style="list-style-type: none"> • Table 4 on page 10 • Table 6 on page 10
*B	5445313	UTSV	09/23/2016	Updated to Cypress template
*C	5746161	AESATP12	05/24/2017	Updated logo and copyright.

Sales, Solutions, and Legal Information

Worldwide Sales and Design Support

Cypress maintains a worldwide network of offices, solution centers, manufacturer's representatives, and distributors. To find the office closest to you, visit us at [Cypress Locations](#).

Products

ARM® Cortex® Microcontrollers	cypress.com/arm
Automotive	cypress.com/automotive
Clocks & Buffers	cypress.com/clocks
Interface	cypress.com/interface
Internet of Things	cypress.com/iot
Lighting & Power Control	cypress.com/powerpsoc
Memory	cypress.com/memory
PSoC	cypress.com/psoc
Touch Sensing	cypress.com/touch
USB Controllers	cypress.com/usb
Wireless/RF	cypress.com/wireless

PSoC® Solutions

[PSoC 1](#) | [PSoC 3](#) | [PSoC 4](#) | [PSoC 5LP](#) | [PSoC 6](#)

Cypress Developer Community

[Forums](#) | [WICED IoT Forums](#) | [Projects](#) | [Video](#) | [Blogs](#) | [Training](#) | [Components](#)

Technical Support

cypress.com/support

© Cypress Semiconductor Corporation, 2016-2017. This document is the property of Cypress Semiconductor Corporation and its subsidiaries, including Spansion LLC ("Cypress"). This document, including any software or firmware included or referenced in this document ("Software"), is owned by Cypress under the intellectual property laws and treaties of the United States and other countries worldwide. Cypress reserves all rights under such laws and treaties and does not, except as specifically stated in this paragraph, grant any license under its patents, copyrights, trademarks, or other intellectual property rights. If the Software is not accompanied by a license agreement and you do not otherwise have a written agreement with Cypress governing the use of the Software, then Cypress hereby grants you a personal, non-exclusive, nontransferable license (without the right to sublicense) (1) under its copyright rights in the Software (a) for Software provided in source code form, to modify and reproduce the Software solely for use with Cypress hardware products, only internally within your organization, and (b) to distribute the Software in binary code form externally to end users (either directly or indirectly through resellers and distributors), solely for use on Cypress hardware product units, and (2) under those claims of Cypress's patents that are infringed by the Software (as provided by Cypress, unmodified) to make, use, distribute, and import the Software solely for use with Cypress hardware products. Any other use, reproduction, modification, translation, or compilation of the Software is prohibited.

TO THE EXTENT PERMITTED BY APPLICABLE LAW, CYPRESS MAKES NO WARRANTY OF ANY KIND, EXPRESS OR IMPLIED, WITH REGARD TO THIS DOCUMENT OR ANY SOFTWARE OR ACCOMPANYING HARDWARE, INCLUDING, BUT NOT LIMITED TO, THE IMPLIED WARRANTIES OF MERCHANTABILITY AND FITNESS FOR A PARTICULAR PURPOSE. To the extent permitted by applicable law, Cypress reserves the right to make changes to this document without further notice. Cypress does not assume any liability arising out of the application or use of any product or circuit described in this document. Any information provided in this document, including any sample design information or programming code, is provided only for reference purposes. It is the responsibility of the user of this document to properly design, program, and test the functionality and safety of any application made of this information and any resulting product. Cypress products are not designed, intended, or authorized for use as critical components in systems designed or intended for the operation of weapons, weapons systems, nuclear installations, life-support devices or systems, other medical devices or systems (including resuscitation equipment and surgical implants), pollution control or hazardous substances management, or other uses where the failure of the device or system could cause personal injury, death, or property damage ("Unintended Uses"). A critical component is any component of a device or system whose failure to perform can be reasonably expected to cause the failure of the device or system, or to affect its safety or effectiveness. Cypress is not liable, in whole or in part, and you shall and hereby do release Cypress from any claim, damage, or other liability arising from or related to all Unintended Uses of Cypress products. You shall indemnify and hold Cypress harmless from and against all claims, costs, damages, and other liabilities, including claims for personal injury or death, arising from or related to any Unintended Uses of Cypress products.

Cypress, the Cypress logo, Spansion, the Spansion logo, and combinations thereof, WICED, PSoC, CapSense, EZ-USB, F-RAM, and Traveo are trademarks or registered trademarks of Cypress in the United States and other countries. For a more complete list of Cypress trademarks, visit cypress.com. Other names and brands may be claimed as property of their respective owners.

Mouser Electronics

Authorized Distributor

Click to View Pricing, Inventory, Delivery & Lifecycle Information:

[Cypress Semiconductor:](#)

[CYW20737L](#)