

## Data Sheet

### Description

The ASMT-Bx20 is an environmental friendly green product of unique PCB based subminiature lamps, namely PCB PolyLED. These PolyLEDs come in un-tinted, non-diffused package to cater for various product themes and ease handling applications.

The small size, narrow footprint, and high brightness make these LEDs excellent for backlighting, status indication, and panel illumination applications.

The available colors are AllnGaP Red, AllnGaP Green, InGaN Blue, and AllnGaP Amber.

In order to facilitate pick and place operation, these PCB PolyLEDs are shipped in tape and reel, with 1500 units per reel. The package is compatible with reflow soldering and binned by both color and intensity.

### Features

- Small foot print
- Available in four colors
- Low power consumption
- Non-diffused dome for high brightness
- Supreme product quality and reliability
- Operating temperature range of -40 °C to +85°C
- Package in 8mm tape on 7" diameter reels
- Compatible with automated placement equipment
- Compatible with infrared and vapor phase reflow soldering process

### Applications

- Panel indicator
- LCD backlighting
- Symbol backlighting
- Push-button backlighting
- Indoor mono/full color sign

### Package Dimensions

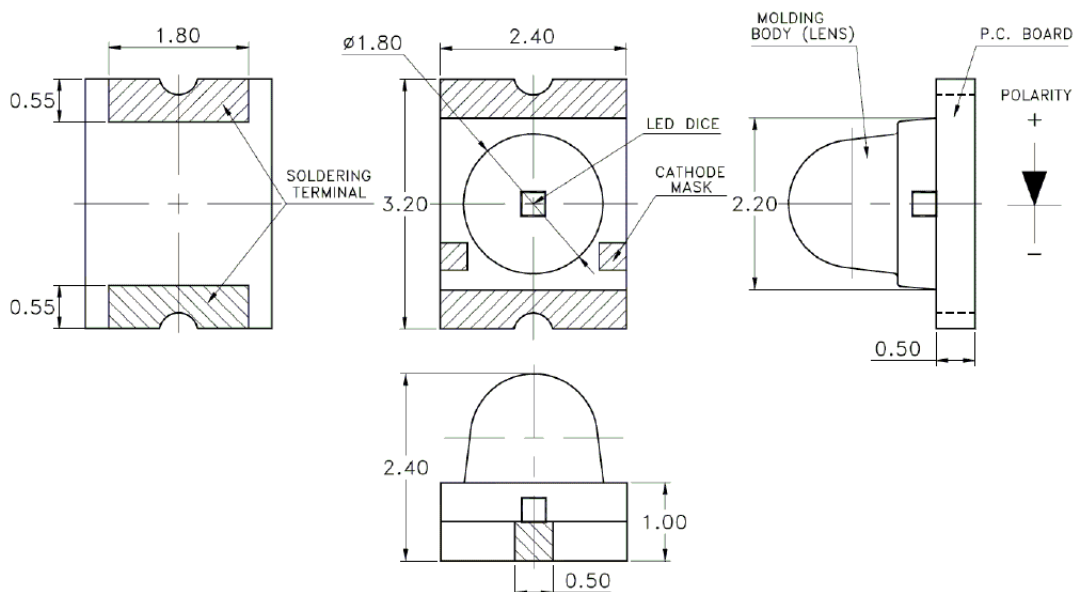

#### Notes:

1. All dimensions in millimeters.
2. Tolerance is  $\pm 0.1$ mm unless otherwise specified.

## Device Selection Guide

Part Number	Die Technology	Color	Package Description
ASMT-BA20	AllnGaP	Amber	Untinted, Non-diffused
ASMT-BG20	AllnGaP	Green	Untinted, Non-diffused
ASMT-BR20	AllnGaP	Red	Untinted, Non-diffused
ASMT-BB20	InGaN	Blue	Untinted, Non-diffused

## Part Numbering System

ASMT - B x 20 - x x x x 0

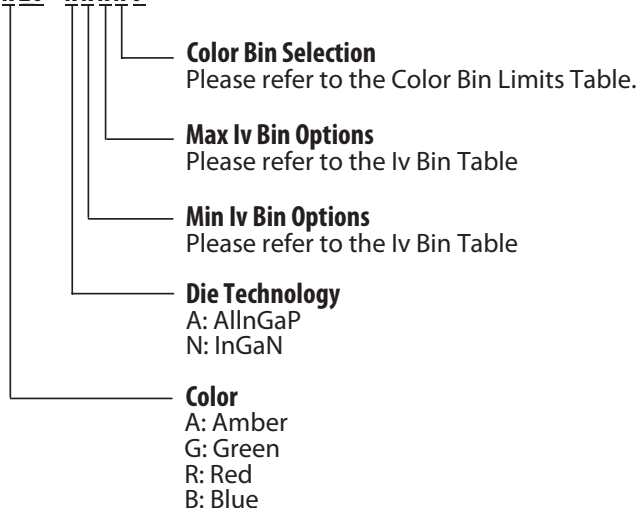

## Absolute Maximum Ratings at $T_A = 25^\circ\text{C}$

Parameter	AllnGaP	InGaN	Units
DC Forward Current <sup>[1]</sup>	30	20	mA
Reverse Voltage ( $I_R = 100\text{mA}$ )	5	5	V
LED Junction Temperature	95	95	$^\circ\text{C}$
Operating Temperature Range	-40 to +85		$^\circ\text{C}$
Storage Temperature Range	-40 to +85		$^\circ\text{C}$
Soldering Temperature (Pb Free)	260 $^\circ\text{C}$ for 10 seconds		

## Electrical Characteristics at $T_A = 25^\circ\text{C}$

Part Number	Forward Voltage	Reverse Breakdown	Thermal Resistance
	$V_F$ (Volts) <sup>[1]</sup> @ $I_F = 20\text{mA}$	$V_R$ (Volts) @ $I_R = 100\mu\text{A}$	$R_{\theta\text{J-PIN}}$ ( $^\circ\text{C}/\text{W}$ )
	Typ.	Min.	Typ.
AllnGaP Amber	2.0	5	450
AllnGaP Green	2.0	5	450
AllnGaP Red	2.0	5	450
InGaN Blue	3.2	5	450

Notes:

1.  $V_F$  tolerance :  $\pm 0.1\text{V}$

## Optical Characteristics at $T_A = 25^\circ\text{C}$

Part Number	Luminous Intensity	Peak Wavelength	Dominant Wavelength	Viewing Angle
	$I_V$ [1] (mcd) @ 20mA Typ.	$\lambda_{\text{peak}}$ (nm) Typ.	$\lambda_d$ [2] (nm) Typ.	$2\theta_{1/2}$ [3] (Degrees) Typ.
AllnGaP Amber	750	592	590	15
AllnGaP Green	650	565	569	15
AllnGaP Red	650	635	626	15
InGaN Blue	650	470	468	15

Notes:

- The luminous intensity  $I_V$  is measured at the peak of the spatial radiation pattern which may not be aligned with the mechanical axis of the LED package.
- The dominant wavelength,  $\lambda_d$ , is derived from the CIE Chromaticity Diagram and represents the perceived color of the device.
- $\theta_{1/2}$  is the off-axis angle where the luminous intensity is  $1/2$  the peak intensity.

### Light Intensity ( $I_V$ ) Bin Limits [1]

Bin ID	Intensity (mcd)	
	Minimum	Maximum
P	45.00	71.50
Q	71.50	112.50
R	112.50	180.00
S	180.00	285.00
T	285.00	450.00
U	450.00	715.00
V	715.00	1125.00
W	1125.00	1800.00
X	1800.00	2850.00
Y	2850.00	4500.00

Tolerance :  $\pm 15\%$

### Color Bin Limits [1]

#### Amber Color Bins [1]

Bin ID	Dominant Wavelength (nm)	
	Minimum	Maximum
1	582.0	584.5
2	584.5	587.0
3	587.0	589.5
4	589.5	592.0
5	592.0	594.5
6	594.5	597.0

Tolerance :  $\pm 1$  nm

Notes:

- Bin categories are established for classification of products. Products may not be available in all categories. Please contact your Avago representative for information on current available bins.

#### Green Color Bins [1]

Bin ID	Dominant Wavelength (nm)	
	Minimum	Maximum
1	561.5	564.5
2	564.5	567.5
3	567.5	570.5
4	570.5	573.5
5	573.5	576.5

Tolerance :  $\pm 1$  nm

#### Red Color Bins [1]

Bin ID	Dominant Wavelength (nm)	
	Minimum	Maximum
-	620.0	635.0

Tolerance :  $\pm 1$  nm

#### Blue Color Bins [1]

Bin ID	Dominant Wavelength (nm)	
	Minimum	Maximum
1	460.0	465.0
2	465.0	470.0
3	470.0	475.0
4	475.0	480.0

Tolerance :  $\pm 1$  nm

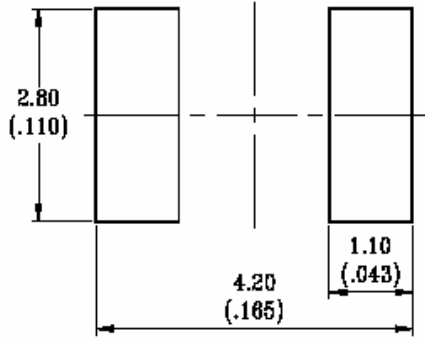

Figure 3. Recommended soldering land pattern.

Notes:

1. All dimensions are in millimeters (inches).
2. Tolerance is  $\pm 0.1\text{mm}$  ( $\pm 0.004\text{in.}$ ) unless otherwise specified.

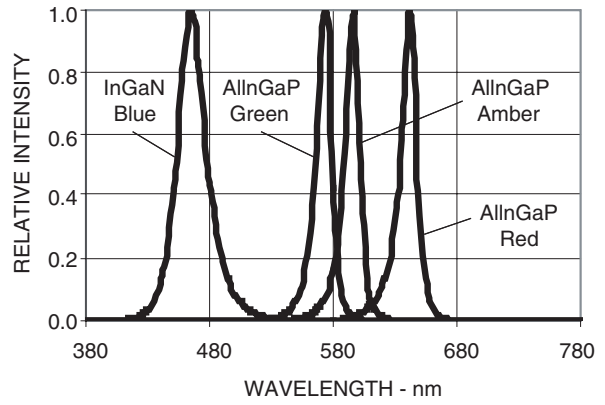

Figure 4. Relative intensity vs. wavelength

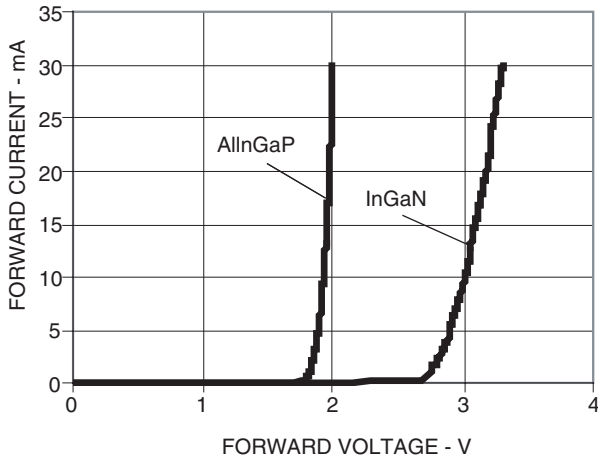

Figure 5. Forward current vs. forward voltage

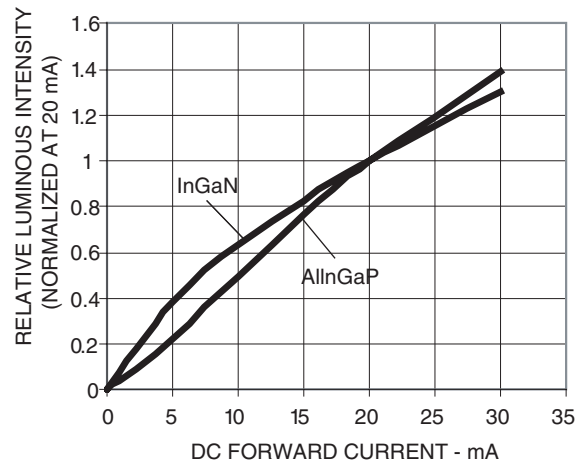

Figure 6. Relative luminous intensity vs. DC forward current

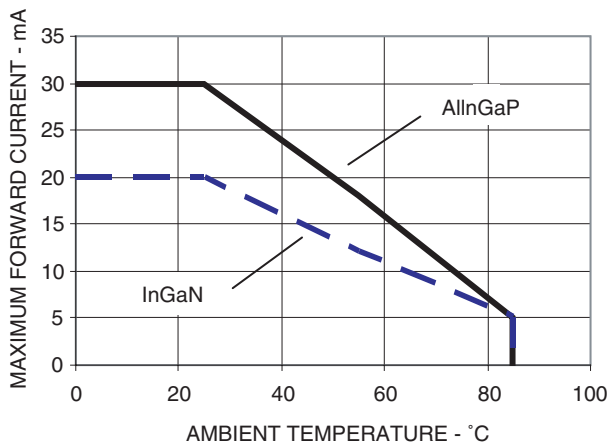

Figure 7. Maximum forward current vs. ambient temperature

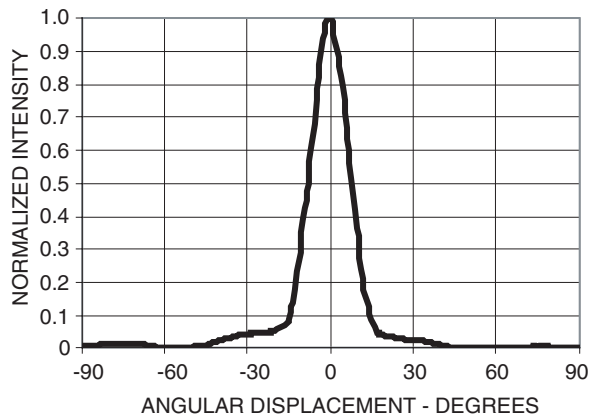

Figure 8. Radiation Pattern For AllnGaP & InGaN Derating based on  $T_{JMAX} = 95^\circ$

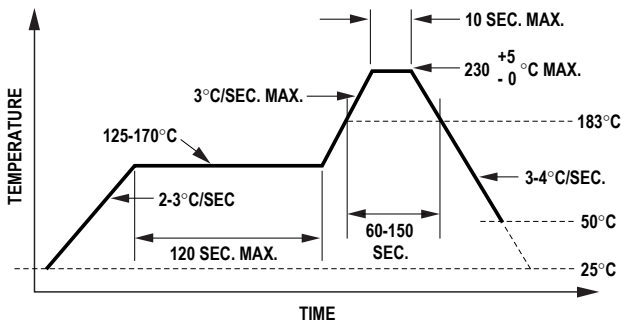
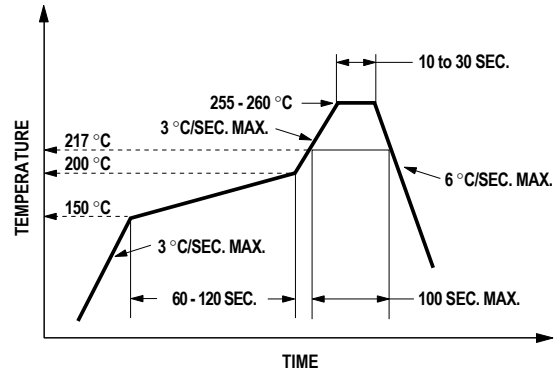

Figure 9. Recommended reflow soldering profile



(Acc. to J-STD-020C)

Figure 10. Recommended Pb-free reflow soldering profile

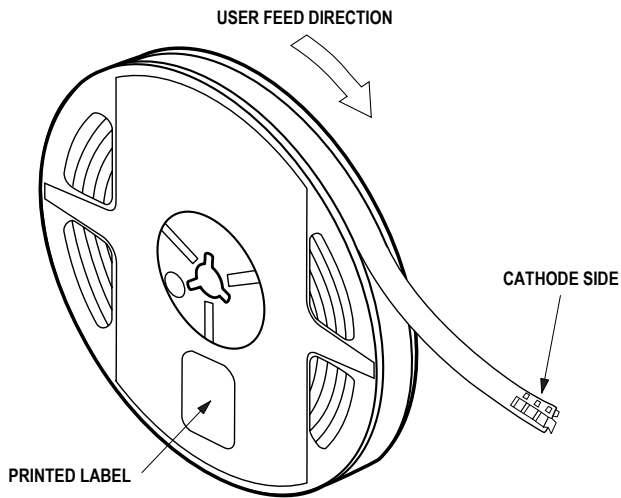

Figure 11. Reeling orientation

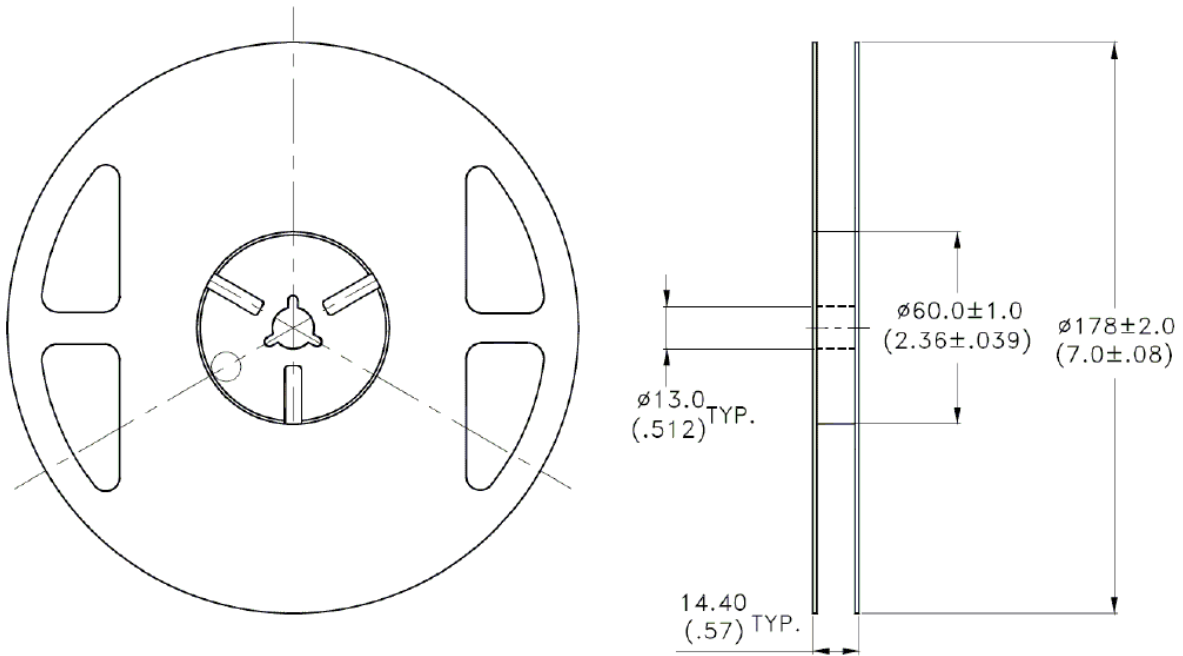

Figure 12. Reel dimensions [1]

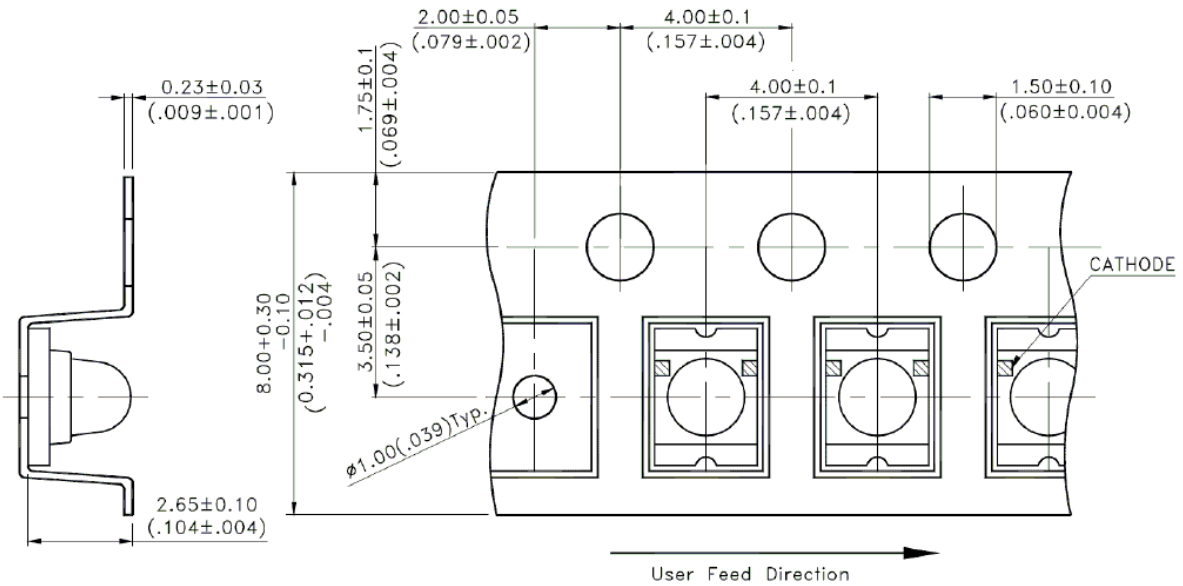

Figure 13. Tape dimensions [1]

Notes:

1. All dimensions are in millimeters (inches).

For product information and a complete list of distributors, please go to our web site: [www.avagotech.com](http://www.avagotech.com)

Avago, Avago Technologies, and the A logo are trademarks of Avago Technologies, Limited in the United States and other countries. Data subject to change. Copyright © 2007 Avago Technologies Limited. All rights reserved. AV02-0389EN - October 30, 2007

