



HIGH-SPEED, FULLY DIFFERENTIAL, CONTINUOUSLY VARIABLE GAIN AMPLIFIER

Check for Samples: [THS7530](#)

FEATURES

- **Low Noise:** $V_n = 1.1 \text{ nV}/\sqrt{\text{Hz}}$,
Noise Figure = 9 dB
- **Low Distortion:**
 - - $\text{HD}_2 = -65 \text{ dBc}$, $\text{HD}_3 = -61 \text{ dBc}$ at 32 MHz
 - - $\text{IMD}_3 = -62 \text{ dBc}$, $\text{OIP}_3 = 21 \text{ dBm}$ at 70 MHz
- **300 MHz Bandwidth**
- **Continuously Variable Gain Range: 11.6 dB to 46.5 dB**
- **Gain Slope: 38.8 dB/V**
- **Fully Differential Input and Output**
- **Output Common-Mode Voltage Control**
- **Output Voltage Limiting**

APPLICATIONS

- **Time Gain Amplifiers in Ultra Sound, Sonar, and Radar**
- **Automatic Gain Control in Communication and Video**
- **System Gain Calibration in Communications**
- **Variable Gain in Instrumentation**

DESCRIPTION

The THS7530 is fabricated using Texas Instruments' state-of-the-art BiCom III SiGe complementary bipolar process. The THS7530 is a dc-coupled, wide bandwidth amplifier with voltage-controlled gain. The amplifier has high-impedance differential inputs and low-impedance differential outputs with high bandwidth gain control, output common-mode control, and output voltage clamping.

Signal channel performance is exceptional with 300-MHz bandwidth, and third harmonic distortion of -61 dBc at 32 MHz with $1\text{-}V_{\text{PP}}$ output into 400Ω .

Gain control is linear in dB with 0 V to 0.9 V varying the gain from 11.6 dB to 46.5 dB with 38.8-dB/V gain slope.

Output voltage limiting is provided to limit the output voltage swing, and prevent saturating following stages.

The device is characterized for operation over the industrial temperature range, -40°C to $+85^\circ\text{C}$.

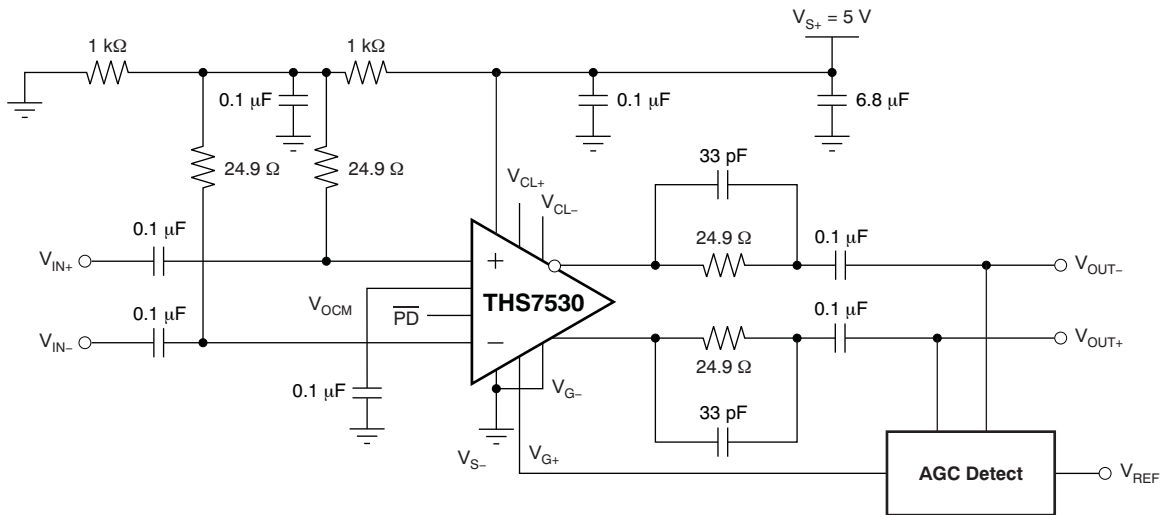

Please be aware that an important notice concerning availability, standard warranty, and use in critical applications of Texas Instruments semiconductor products and disclaimers thereto appears at the end of this data sheet.

PowerPAD is a trademark of Texas Instruments.

All other trademarks are the property of their respective owners.



This integrated circuit can be damaged by ESD. Texas Instruments recommends that all integrated circuits be handled with appropriate precautions. Failure to observe proper handling and installation procedures can cause damage.

ESD damage can range from subtle performance degradation to complete device failure. Precision integrated circuits may be more susceptible to damage because very small parametric changes could cause the device not to meet its published specifications.

PACKAGING/ORDERING INFORMATION⁽¹⁾

PART NUMBER	PACKAGE TYPE	PACKAGE MARKING	TRANSPORT MEDIA, QUANTITY
THS7530PWP	TSSOP-14-PP	THS7530	Rails, 90
THS7530PWPR			Tape and Reel, 2000

(1) For the most current package and ordering information, see the Package Option Addendum at the end of this document or see the TI web site at www.ti.com.

ABSOLUTE MAXIMUM RATINGS⁽¹⁾

Over operating free-air temperature range, unless otherwise noted.

		THS7530
$V_{S+} - V_{S-}$	Supply voltage	5.5 V
V_I	Input voltage	$\pm V_S$
I_O	Output current	65 mA
V_{ID}	Differential input voltage	± 4 V
Continuous power dissipation		See Dissipation Rating Table
T_J	Maximum junction temperature	+150°C
	Maximum junction temperature for long term stability ⁽²⁾	+125°C
T_{stg}	Storage temperature range	-65°C to +150°C
ESD	HBM	3000 V
	CDM	1500 V
	MM	200 V

- (1) The absolute maximum ratings under any condition is limited by the constraints of the silicon process. Stresses above these ratings may cause permanent damage. Exposure to absolute maximum conditions for extended periods may degrade device reliability. These are stress ratings only, and functional operation of the device at these or any other conditions beyond those specified is not implied.
- (2) The maximum junction temperature for continuous operation is limited by package constraints. Operation above this temperature may result in reduced reliability and/or lifetime of the device.

PACKAGE THERMAL DATA

PACKAGE	PCB	θ_{JA} (°C/W)	θ_{JC} (°C/W) ⁽¹⁾	$T_A = 25^\circ\text{C}$ POWER RATING ⁽²⁾
PWP (14-pin) ⁽³⁾	See Layout Considerations in the Application section of this data sheet.	37.5	2.07	3 W

- (1) This data was taken using the JEDEC High-K test printed circuit board (PCB).
- (2) This data was taken using 2 oz. trace and copper pad that is soldered directly to a 3 in x 3 in PCB.
- (3) The THS7530 incorporates a PowerPAD™ on the underside of the chip. This acts as a heatsink and must be connected to a thermally dissipative plane for proper power dissipation. Failure to do so may result in exceeding the maximum junction temperature which could permanently damage the device. See TI technical briefs [SLMA002](#) and [SLMA004](#) for more information about using the PowerPAD thermally enhanced package.

RECOMMENDED OPERATING CONDITIONS

		TEST CONDITIONS	MIN	TYP	MAX	UNIT
$[V_{S-} \text{ to } V_{S+}]$	Supply voltage		4.5	5	5.5	V
T_A	Operating free-air temperature		-40		+85	°C
	Input common mode voltage	$[V_{S-} \text{ to } V_{S+}] = 5$ V		2.5		V
	Output common mode voltage	$[V_{S-} \text{ to } V_{S+}] = 5$ V		2.5		V

SPECIFICATIONS: MAIN AMPLIFIER

$V_{S+} = 5\text{ V}$, $V_{S-} = 0\text{ V}$, $V_{OCM} = 2.5\text{ V}$, $V_{ICM} = 2.5\text{ V}$, $V_{G-} = 0\text{ V}$, $V_{G+} = 1\text{ V}$ (maximum gain), $T_A = 25^\circ\text{C}$, ac performance measured using the ac test circuit shown in [Figure 1](#) (unless otherwise noted). DC performance is measured using the dc test circuit shown in [Figure 2](#) (unless otherwise noted)

PARAMETER	TEST CONDITIONS	TYP	OVER TEMPERATURE			UNITS	MIN/ MAX
		+25°C	+25°C	-40°C to +85°C			
AC PERFORMANCE (See Figure 1)							
Small-signal bandwidth	All gains, $P_{IN} = -45\text{ dBm}$	300				MHz	Typ
Slew rate ⁽¹⁾	1- V_{PP} Step, 25% to 75%, minimum gain	1250				V/ μs	Typ
Settling time to 1% ⁽¹⁾	1- V_{PP} Step, minimum gain	11				ns	Typ
Harmonic distortion	$V_{O(PP)} = 1\text{ V}$, $R_{L(diff)} = 400\ \Omega$						
2nd Harmonic	$f = 32\text{ MHz}$	-65				dBc	Typ
3rd Harmonic	$f = 32\text{ MHz}$	-61				dBc	Typ
Third-order intermodulation distortion	$P_O = -10\text{ dBm}$ each tone, $f_C = 70\text{ MHz}$, 200-kHz tone spacing	-62				dBc	Typ
Third-order output intercept point	$f_C = 70\text{ MHz}$, 200-kHz tone spacing	21				dBm	Typ
Noise figure (with input termination)	Source impedance: $50\ \Omega$	9				dB	Typ
Total input voltage noise	$f > 100\text{ kHz}$	1.1				nV/ $\sqrt{\text{Hz}}$	Typ
DC PERFORMANCE—INPUTS (See Figure 2)							
Input bias current		20	39	40		μA	Max
Input bias current offset		<150				pA	Typ
Minimum input voltage	Minimum gain	1.5	1.6	1.7		V	Max
Maximum input voltage	Minimum gain	3.5	3.35	3.2		V	Min
Common-mode rejection ratio		114	56	44		dB	Min
Differential input impedance		8.5 3.0				k Ω pF	Typ
DC PERFORMANCE—OUTPUTS (See Figure 2)							
Output offset voltage	All gains	± 100	± 340	± 480		mV	Max
Maximum output voltage high		3.5	3.275	3.25		V	Min
Minimum output voltage low		1.5	1.7	1.8		V	Max
Output current		± 37	± 16	± 16		mA	Min
Output impedance		15				Ω	Typ
OUTPUT COMMON-MODE VOLTAGE CONTROL (See Figure 2)							
Small-signal bandwidth		32				MHz	Typ
Gain		1.00				V/V	Typ
Common-mode offset voltage		4.5	12	13.8		mV	Max
Minimum input voltage		1.75				V	Typ
Maximum input voltage		3.25				V	Typ
Input impedance		25 1				k Ω pF	Typ
Default voltage, with no connect		2.5				V	Typ
Input bias current		<1				μA	Typ

(1) Slew rate and settling time measured at amplifier output.

SPECIFICATIONS: MAIN AMPLIFIER (continued)

$V_{S+} = 5\text{ V}$, $V_{S-} = 0\text{ V}$, $V_{OCM} = 2.5\text{ V}$, $V_{ICM} = 2.5\text{ V}$, $V_{G-} = 0\text{ V}$, $V_{G+} = 1\text{ V}$ (maximum gain), $T_A = 25^\circ\text{C}$, ac performance measured using the ac test circuit shown in [Figure 1](#) (unless otherwise noted). DC performance is measured using the dc test circuit shown in [Figure 2](#) (unless otherwise noted)

PARAMETER	TEST CONDITIONS	OVER TEMPERATURE				
		+25°C	+25°C	-40°C to +85°C	UNITS	MIN/ MAX
GAIN CONTROL (See Figure 2)						
Gain control differential voltage range	V_{G+}	0 to 1			V	Typ
Minus gain control voltage	$V_{G-} - V_{S-}$	-0.6 to 0.8			V	Typ
Minimum gain	$V_{G+} = 0\text{ V}$	11.6			dB	Typ
Maximum gain	$V_{G+} = 0.9\text{ V}$	46.5			dB	Typ
Gain slope	$V_{G+} = 0\text{ V}$ to 0.9 V	38.8			dB/V	Typ
Gain slope variation	$V_{G+} = 0\text{ V}$ to 0.9 V	± 1.5			dB/V	Typ
Gain error	$V_{G+} = 0\text{ V}$ to 0.15 V	± 4			dB	Typ
	$V_{G+} = 0.15\text{ V}$ to 0.9 V	± 2.25			dB	Typ
Gain control input bias current		<1			μA	Typ
Gain control input resistance		40			k Ω	Typ
Gain control bandwidth	Small signal -3 dB	15			MHz	Typ
VOLTAGE CLAMPING (See Figure 2)						
Output voltages ($V_{OUT\pm}$) relative to clamp voltages ($V_{CL\pm}$)	In voltage limiting mode	± 25	± 38	± 60	mV	Max
$V_{CL\pm}$ Input resistance		3.3			k Ω	Typ
$V_{CL\pm}$ Voltage limits		V_{S-} to V_{S+}			V	Typ
POWER SUPPLY (See Figure 2)						
Specified operating voltage		5	5.5	5.5	V	Max
Maximum quiescent current		40	48	49	mA	Max
Power supply rejection ($\pm\text{PSRR}$)		77	70	45	dB	Min
POWERDOWN (See Figure 2)						
Enable voltage threshold	TTL low = shut down	1.4		1.0	V	Min
Disable voltage threshold	TTL high = normal operation	1.4		1.65	V	Max
Power-down quiescent current		0.35	0.4	0.45	mA	Max
Input current high		9	16	19	μA	Max
Input current low		109	116	119	μA	Max
Input impedance		50 1			k Ω pF	Typ
Turn-on time delay	Measured to 50% quiescent current	820			ns	Typ
Turn-off time delay		500			ns	Typ
Forward isolation in power down		80			dB	Typ
Input resistance in power down		> 1			M Ω	Typ
Output resistance in power down		16			k Ω	Typ

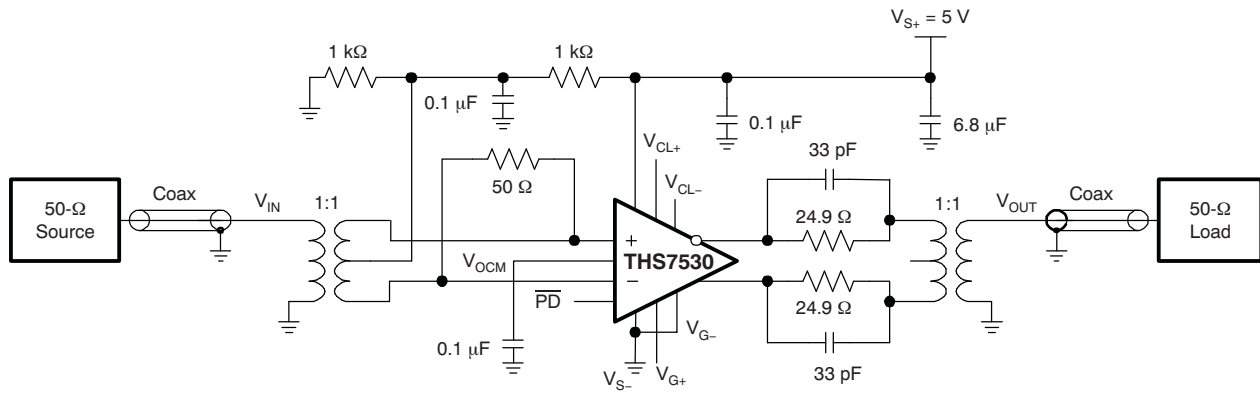

Figure 1. AC Test Circuit

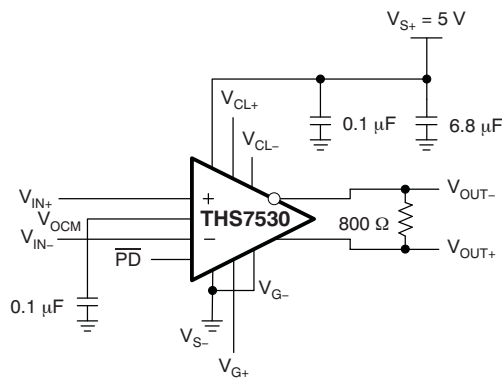

Figure 2. DC Test Circuit

PIN ASSIGNMENTS

TSSOP PACKAGE
PWP-14
(TOP VIEW)

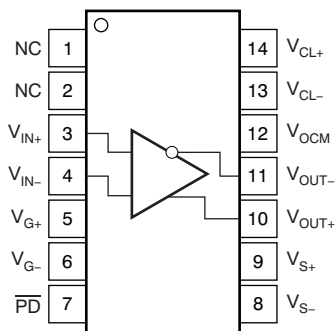

Table 1. Terminal Functions

TERMINAL		DESCRIPTION
NO.	NAME	
1	NC	No internal connection
2	NC	No internal connection
3	V _{IN+}	Noninverting amplifier input
4	V _{IN-}	Inverting amplifier input
5	V _{G+}	Gain setting positive input
6	V _{G-}	Gain setting negative input
7	$\overline{\text{PD}}$	Powerdown, $\overline{\text{PD}}$ = logic low puts part into low power mode; $\overline{\text{PD}}$ = logic high or open for normal operation
8	V _{S-}	Negative amplifier power-supply input
9	V _{S+}	Positive amplifier power-supply input
10	V _{OUT+}	Noninverted amplifier output
11	V _{OUT-}	Inverted amplifier output
12	V _{OCM}	Output common-mode voltage input
13	V _{CL-}	Output negative clamp voltage input
14	V _{CL+}	Output positive clamp voltage input

TYPICAL CHARACTERISTICS

Table of Graphs

Measured using the ac test circuit shown in [Figure 1](#) (unless otherwise noted).

		Figure
Voltage Gain to Load	vs Frequency (Input at 45 dBm)	Figure 3
Gain and Gain Error	vs V_{G+}	Figure 4
Noise Figure	vs Frequency	Figure 5
Output Intercept Point	vs Frequency	Figure 6
1-dB Compression Point	vs Frequency	Figure 7
Total Input Voltage Noise	vs Frequency	Figure 8
Intermodulation Distortion	vs Frequency	Figure 9
Harmonic Distortion	vs Frequency	Figure 10
S-Parameters	vs Frequency	Figure 11
Differential Input Impedance of Main Amplifier	vs Frequency	Figure 12
Differential Output Impedance of Main Amplifier	vs Frequency	Figure 13
V_{G+} Input Impedance	vs Frequency	Figure 14
V_{OCM} Input Impedance	vs Frequency	Figure 15
Common-Mode Rejection Ratio	vs Frequency	Figure 16
Step Response: $2 V_{PP}$	vs Time	Figure 17
Step Response: Rising Edge	vs Time	Figure 18
Step Response: Falling Edge	vs Time	Figure 19

TYPICAL CHARACTERISTICS

**VOLTAGE GAIN TO LOAD
vs
FREQUENCY ($P_{IN} = -45 \text{ dBm}$)**

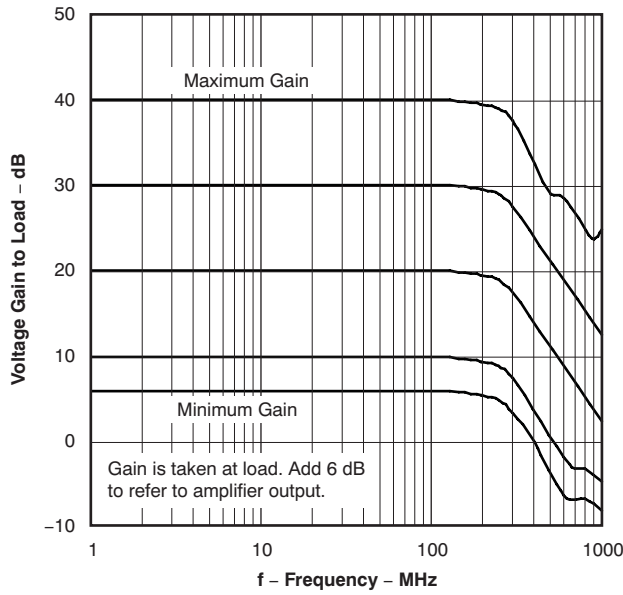

Figure 3.

**GAIN AND GAIN ERROR
vs
 V_{G+}**

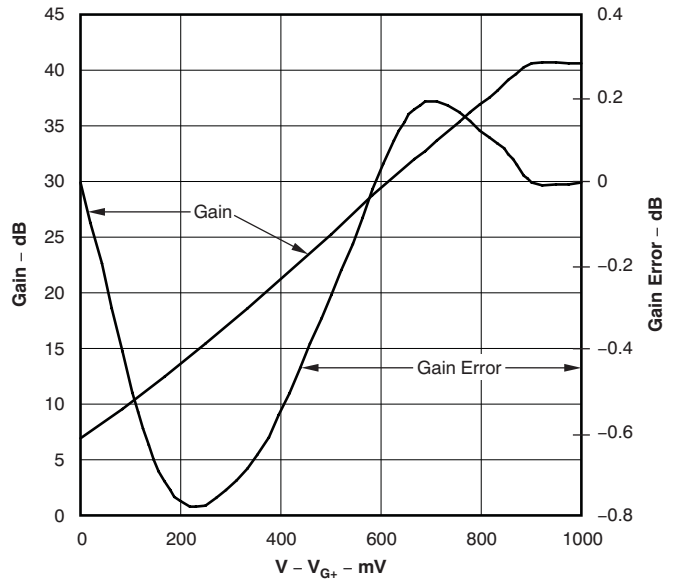

Figure 4.

**NOISE FIGURE
vs
FREQUENCY**

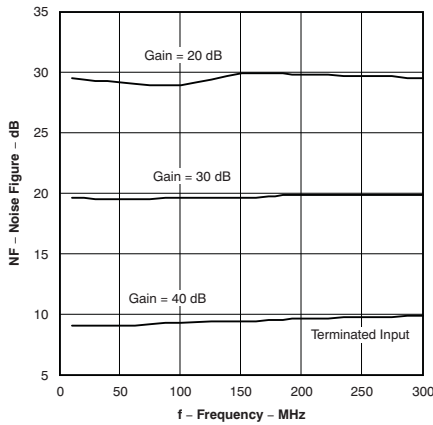

Figure 5.

**OUTPUT INTERCEPT POINT
vs
FREQUENCY**

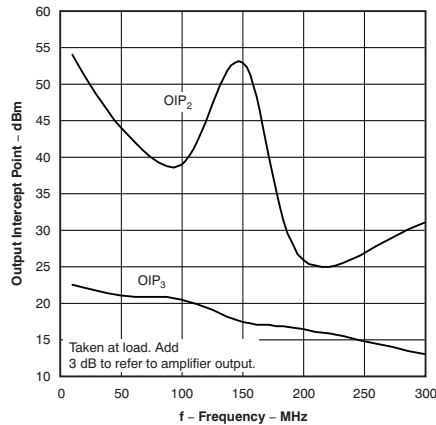

Figure 6.

**1-dB COMPRESSION POINT
vs
FREQUENCY**

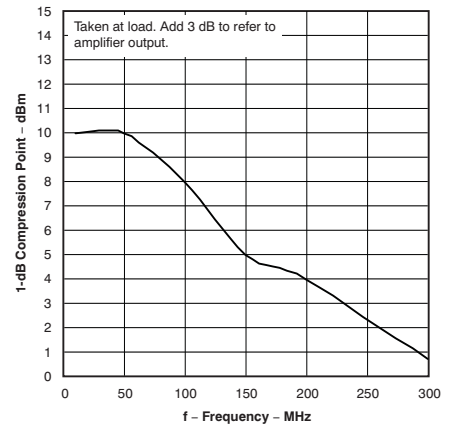

Figure 7.

TYPICAL CHARACTERISTICS (continued)

TOTAL INPUT VOLTAGE NOISE VS FREQUENCY

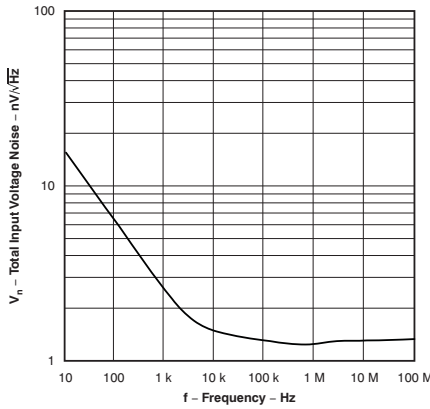

Figure 8.

INTERMODULATION DISTORTION VS FREQUENCY

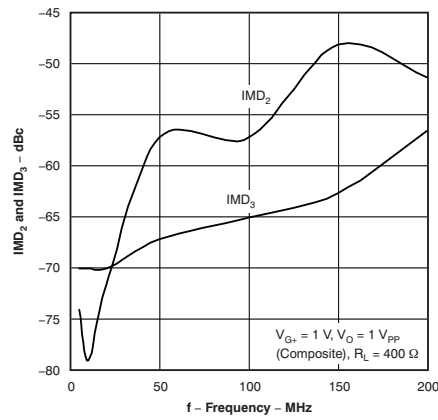

Figure 9.

HARMONIC DISTORTION VS FREQUENCY

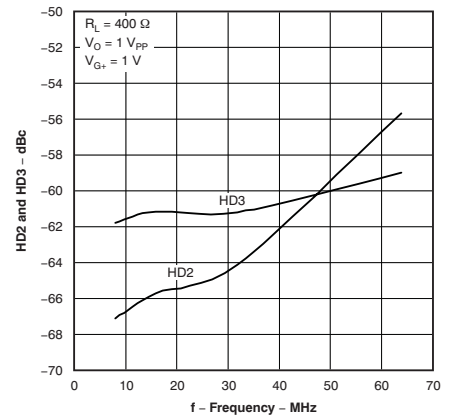

Figure 10.

S-PARAMETERS VS FREQUENCY

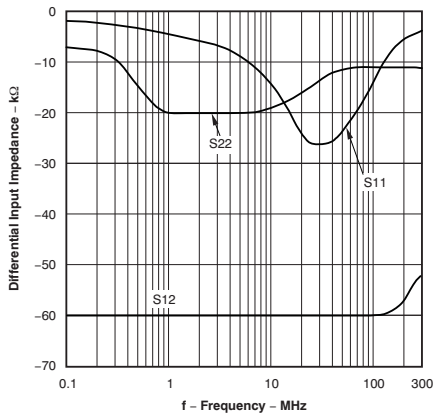

Figure 11.

DIFFERENTIAL INPUT IMPEDANCE OF MAIN AMPLIFIER VS FREQUENCY

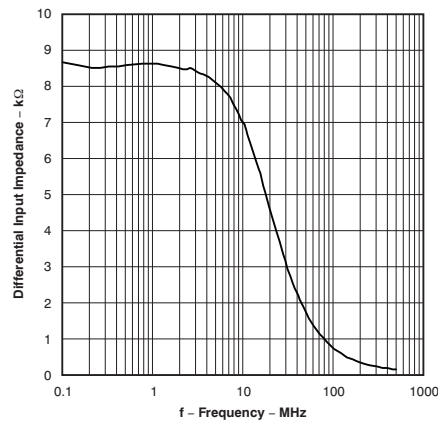

Figure 12.

DIFFERENTIAL OUTPUT IMPEDANCE OF MAIN AMPLIFIER VS FREQUENCY

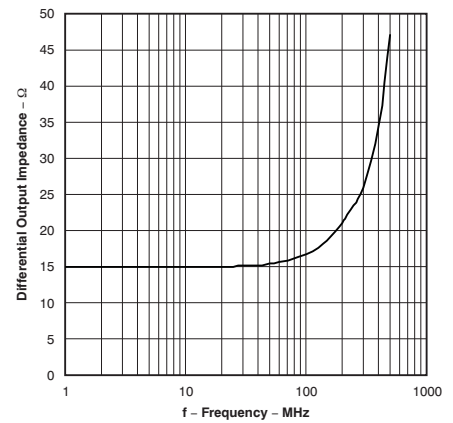

Figure 13.

TYPICAL CHARACTERISTICS (continued)

**V_{G+} INPUT IMPEDANCE
VS
FREQUENCY**

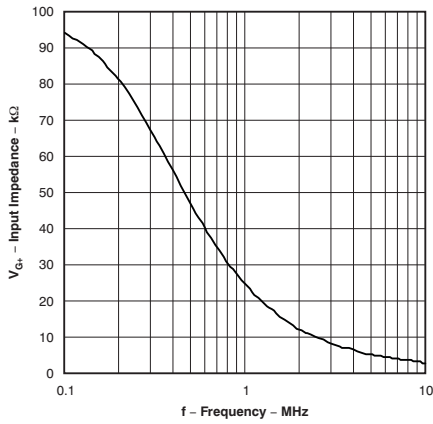

Figure 14.

**V_{OCM} INPUT IMPEDANCE
VS
FREQUENCY**

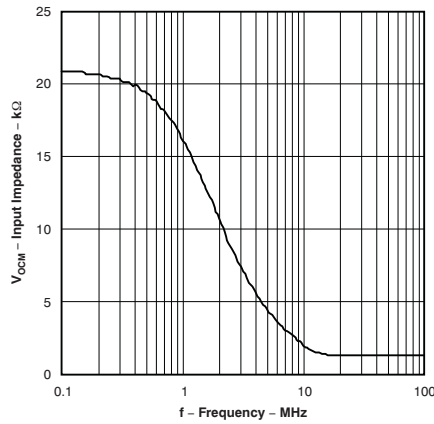

Figure 15.

**COMMON-MODE REJECTION RATIO
VS
FREQUENCY**

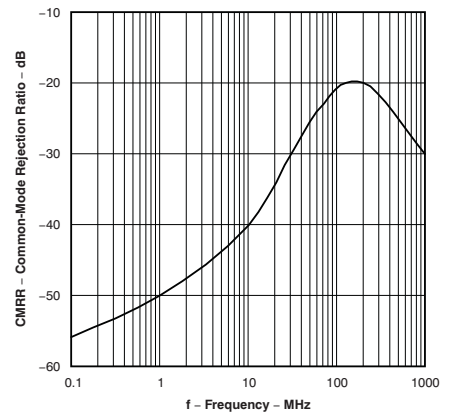

Figure 16.

STEP RESPONSE

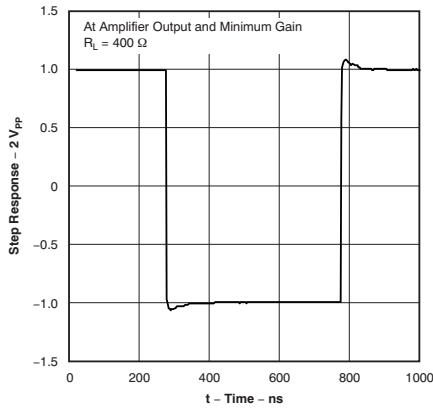

Figure 17.

STEP RESPONSE: RISING EDGE

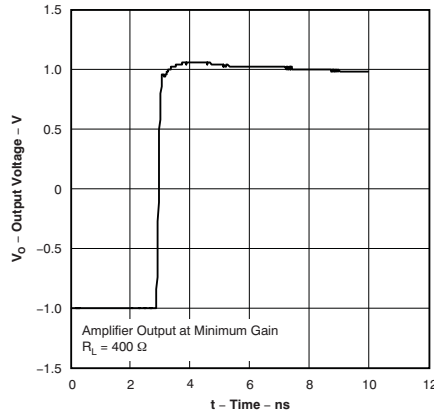

Figure 18.

STEP RESPONSE: FALLING EDGE

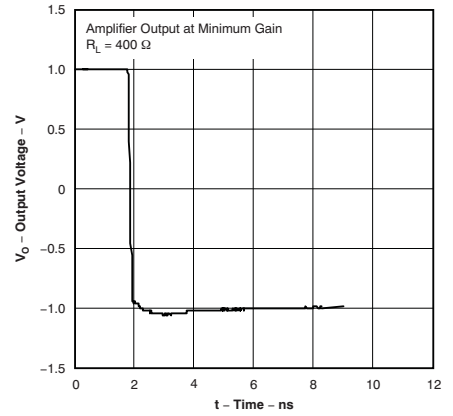

Figure 19.

APPLICATION INFORMATION

The THS7530 is designed for nominal 5-V power supply from V_{S+} to V_{S-} .

The amplifier has fully differential inputs, V_{IN+} and V_{IN-} , and fully differential outputs, V_{OUT+} and V_{OUT-} . The inputs are high impedance and outputs are low impedance. External resistors are recommended for impedance matching and termination purposes.

The inputs and outputs can be dc-coupled, but for best performance, the input and output common-mode voltage should be maintained at the midpoint between the two supply pins. The output common-mode voltage is controlled by the voltage applied to V_{OCM} . Left unterminated, V_{OCM} is set to midsupply by internal resistors. A 0.1- μ F bypass capacitor should be placed between V_{OCM} and ground to reduce common-mode noise. The input common-mode voltage defaults to midrail when left unconnected. For voltages other than midrail, V_{OCM} must be biased by external means. V_{IN+} and V_{IN-} both require a nominal 30- μ A bias current for proper operation. Therefore, ensure equal input impedance at each input to avoid generating an offset voltage that varies with gain.

Voltage applied from V_{G-} to V_{G+} controls the gain of the part with 38.8-dB/V gain slope. The input can be differential or single ended. V_{G-} must be maintained within -0.6 V and $+0.8$ V of V_{S-} for proper operation. The negative gain input should typically be tied directly to the negative power supply.

V_{CL+} and V_{CL-} are inputs that limit the output voltage swing of the amplifier. The voltages applied set an absolute limit on the voltages at the output. Input voltages at V_{CL+} and V_{CL-} clamp the output, ensuring that neither output exceeds those values.

The power-down input is a TTL compatible input, referenced to the negative supply voltage. A logic low puts the THS7530 in power-saving mode. In power-down mode the part consumes less than 1-mA current, the output goes high impedance, and a high amount of isolation is maintained between the input and output.

Power-supply bypass capacitors are required for proper operation. A 6.8- μ F tantalum bulk capacitor is recommended if the amplifier is located far from the power supply and may be shared among other devices. A ceramic 0.1- μ F capacitor is recommended within 0.1-in of the device power pin. The ceramic capacitors should be located on the same layer as the amplifier to eliminate the use of vias between the capacitors and the power pin.

Figure 20 through Figure 24 show some basic circuit configurations.

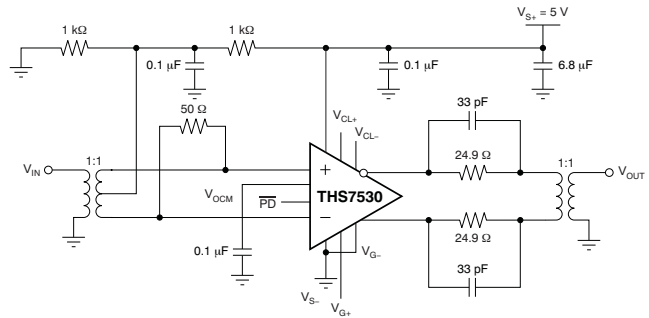

Figure 20. EVM Schematic: Designed for Use with Typical 50- Ω RF Test Equipment

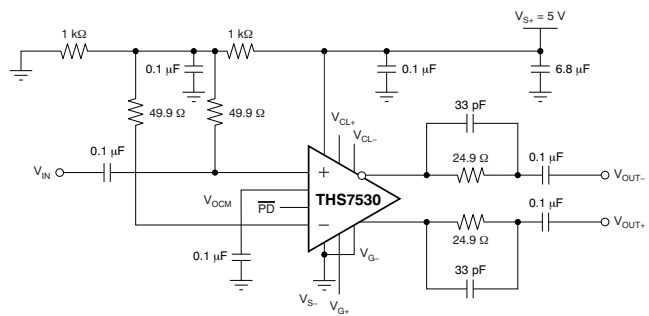

Figure 21. AC-Coupled Single-Ended Input with AC-Coupled Differential Output

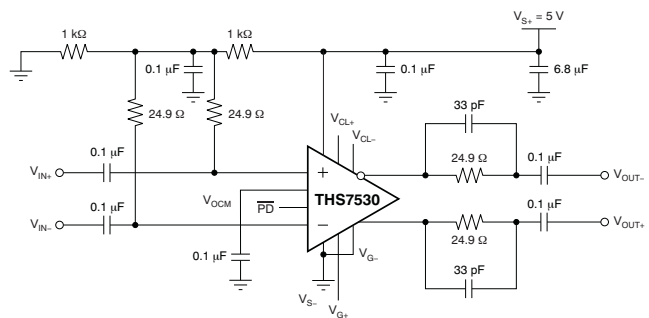

Figure 22. AC-Coupled Differential Input with AC-Coupled Differential Output

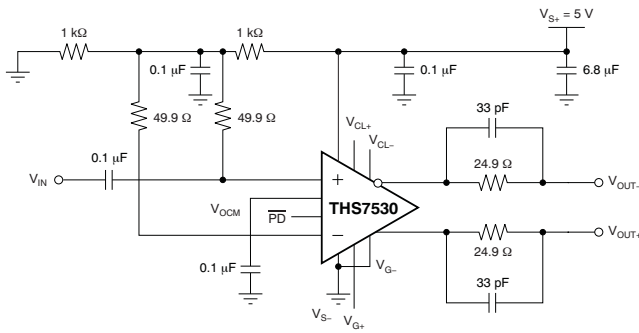

Figure 23. DC-Coupled Single-Ended Input with DC-Coupled Differential Output

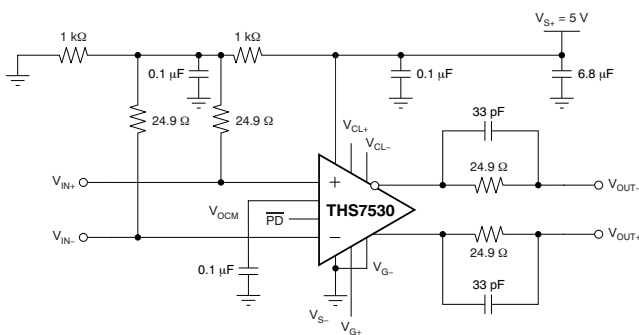

Figure 24. DC-Coupled Differential Input with DC-Coupled Differential Output

LAYOUT CONSIDERATIONS

The THS7530 comes in a thermally-enhanced PowerPAD™ package. Figure 25 shows the recommended number of vias and thermal land size recommended for best performance. Thermal vias connect the thermal land to internal or external copper planes and should have a drill diameter sufficiently small so that the via hole is effectively plugged when the barrel of the via is plated with copper. This plug is needed to prevent wicking the solder away from the interface between the package body and the thermal land on the surface of the board during solder reflow. The experiments conducted jointly with Solectron Texas indicate that a via drill diameter of 0,33 mm (13 mils, or .013 in) or smaller works well when 1-ounce copper is plated at the surface of the board and simultaneously plating the barrel of the via. If the thermal vias are not plugged when the copper plating is performed, then a solder mask material should be used to cap the vias with a dimension equal to the via diameter + 0,1 mm minimum. This prevents the solder from being wicked through the thermal via and potentially creating a solder void in the region between the package bottom and the thermal land on the surface of the PCB.

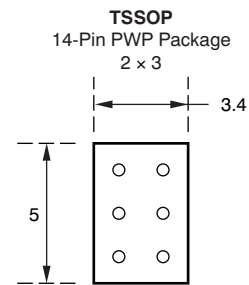

Figure 25. Recommended Thermal Land Size and Thermal Via Patterns (Dimensions in mm)

See TI's Technical Brief titled, *PowerPAD™ Thermally Enhanced Package (SLMA002)* for a detailed discussion of the PowerPAD™ package, its dimensions, and recommended use.

THEORY OF OPERATION

Figure 26 shows a simplified schematic of the THS7530.

The input architecture is a modified Gilbert cell. The output from the Gilbert cell is converted to a voltage and buffered to the output as a fully-differential signal. A summing node between the outputs is used to compare the output common-mode voltage to the V_OCM input. The V_OCM error amplifier then servos the output common-mode voltage to maintain it equal to the V_OCM input. Left unterminated, V_OCM is set to midsupply by internal resistors.

The gain control input is conditioned to give linear-in-dB gain control (block H). The gain control input is a differential signal from 0 V to 0.9 V which varies the gain from 11.6 dB to 46.5 dB.

V_CL+ and V_CL- provide inputs that limit the output voltage swing of the amplifier.

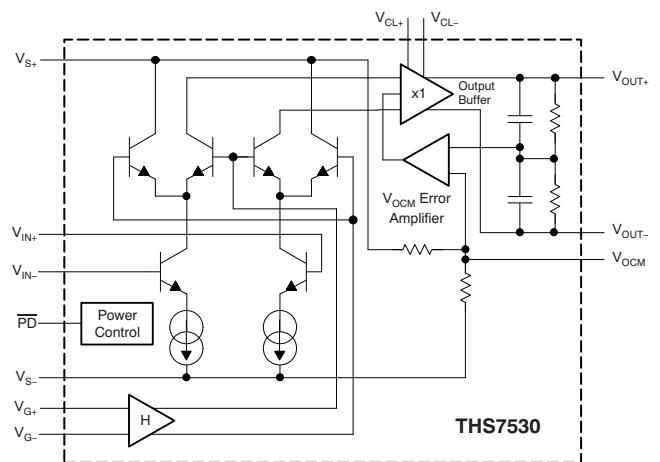

Figure 26. THS7530 Simplified Schematic

SPICE MODEL

```
* [Disclaimer] (C) Copyright Texas Instruments Incorporated 1999-2002 All rights reserved
* Texas Instruments Incorporated hereby grants the user of this SPICE Macro-model a
* non-exclusive, nontransferable license to use this SPICE Macro-model under the following
* terms. Before using this SPICE Macro-model, the user should read this license. If the
* user does not accept these terms, the SPICE Macro-model should be returned to Texas
* Instruments within 30 days. The user is granted this license only to use the SPICE
* Macro-model and is not granted rights to sell, load, rent, lease or license the SPICE
* Macro-model in whole or in part, or in modified form to anyone other than user. User may
* modify the SPICE Macro-model to suit its specific applications but rights to derivative
* works and such modifications shall belong to Texas Instruments. This SPICE Macro-model is
* provided on an "AS IS" basis and Texas Instruments makes absolutely no warranty with
* respect to the information contained herein. TEXAS INSTRUMENTS DISCLAIMS AND CUSTOMER
* WAIVES ALL WARRANTIES, EXPRESS OR IMPLIED, INCLUDING WARRANTIES OF MERCHANTABILITY
* OR FITNESS FOR A PARTICULAR PURPOSE. The entire risk as to quality and performance is with
* the Customer. ACCORDINGLY, IN NO EVENT SHALL THE COMPANY BE LIABLE FOR ANY DAMAGES,
* WHETHER IN CONTRACT OR TORT, INCLUDING ANY LOST PROFITS OR OTHER INCIDENTAL, CONSEQUENTIAL,
* EXEMPLARY, OR PUNITIVE DAMAGES ARISING OUT OF THE USE OR APPLICATION OF THE SPICE
* Macro-model provided in this package. Further, Texas Instruments reserves the right to
* discontinue or make changes without notice to any product herein to improve reliability,
* function, or design. Texas Instruments does not convey any license under patent rights or
* any other intellectual property rights, including those of third parties.
```

```
*
* THS7530 SUBCIRCUIT
* HIGH SPEED FULLY DIFFERENTIAL VARIABLE AMPLIFIER
* WRITTEN 11/26/02
* VG- is tied to VS- and output clamping is not modeled
* CONNECTIONS: IN+
```

```
* | IN-
* | | VS+
* | | | VS-
* | | | | OUT-
* | | | | | OUT+
* | | | | | | VOVM
* | | | | | | VG+
* | | | | | |
.SUBCKT THS7530 1 2 3 4 5 6 7 8
```

```
*
*INPUT*
Q1 122 1 101 NPN_IN 16
Q2 123 2 102 NPN_IN 16
R1 102 101 25
I1 101 4 DC 4.85e-3
I2 102 4 DC 4.85e-3
*QUAD*
Q3 132 120 122 NPN 16
Q4 121 119 122 NPN 16
Q5 132 119 123 NPN 16
Q6 121 120 123 NPN 16
R2 132 3 250
R3 121 3 250
*CURRENT AMP*
F1 128 129 VF1 6
VF1 132 121 0V
*Z NODE*
R4 128 129 2k
I3 129 4 DC 0.75e-3
I4 128 4 DC 0.75e-3
V9 128 328 0.7
V10 129 329 0.7
```

```

*FREQUENCY SHAPING*
E3 131 0 329 0 1
R5 131 140 30
L3 140 133 7.5n
C6 133 0 24p
E4 130 0 328 0 1
R9 130 141 30
L4 141 125 10n
C7 125 0 27p
*OUTPUT BUFFER*
Q9 4 133 117 PNP 5.12
Q10 3 133 127 NPN 5.12
Q11 3 117 134 NPN 81.92
Q12 4 127 135 PNP 81.92
Q13 4 125 116 PNP 5.12
Q14 3 125 126 NPN 5.12
Q15 3 116 136 NPN 81.92
Q16 4 126 137 PNP 81.92
R6 138 134 5
R7 135 138 5
R10 139 136 5
R11 137 139 5
I5 3 117 DC 0.4e-3
I6 127 4 DC 0.4e-3
I7 3 116 DC 0.4e-3
I8 126 4 DC 0.4e-3
*OUTPUT Z*
R8 113 138 2
R12 115 139 2
L1 113 5 4n
L2 115 6 4n
C1 6 5 2p
*VOCM
Rcm1 115 114 8k
Ccml 115 114 0.1p
Rcm2 114 113 8k
Ccm2 114 113 0.1p
E1 118 0 114 7 1e3
Rtop 3 7 50k
Rbot 4 7 50k
Q7 128 118 3 PNP 16
Q8 129 118 3 PNP 16
*GAIN CONTROL*
V8 235 8 0.454
E5 231 0 235 4 0.51
E6 232 0 POLY(1) 231 0 0.0 1 1 0.5 3.5
E7 233 0 232 0 0.115
E8 234 0 POLY(1) 233 0 0.0 0 1 0 0.333
E9 120 119 234 0 0.42
V7 3 120 1.6
Rsupply 3 4 310
.MODEL NPN_IN NPN
+ KF=1E-12
.MODEL NPN NPN
.MODEL PNP PNP
.ENDS

```

REVISION HISTORY

Changes from Revision B (February, 2006) to Revision C	Page
• Corrected polarity indication on input and output in front-page figure	1
• Deleted <i>lead temperature</i> specification from Absolute Maximum Ratings table	2
• Corrected Figure 2	5
• Changed Figure 21 and Figure 22 to correct problem with output polarity indication	11
• Changed Figure 23 and Figure 24 to correct problem with output polarity indication	12

PACKAGING INFORMATION

Orderable Device	Status (1)	Package Type	Package Drawing	Pins	Package Qty	Eco Plan (2)	Lead/Ball Finish (6)	MSL Peak Temp (3)	Op Temp (°C)	Device Marking (4/5)	Samples
THS7530PWP	ACTIVE	HTSSOP	PWP	14	90	Green (RoHS & no Sb/Br)	CU NIPDAU	Level-2-260C-1 YEAR	-40 to 85	THS7530	Samples
THS7530PWPG4	ACTIVE	HTSSOP	PWP	14	90	Green (RoHS & no Sb/Br)	CU NIPDAU	Level-2-260C-1 YEAR	-40 to 85	THS7530	Samples
THS7530PWPR	ACTIVE	HTSSOP	PWP	14	2000	Green (RoHS & no Sb/Br)	CU NIPDAU	Level-2-260C-1 YEAR	-40 to 85	THS7530	Samples

(1) The marketing status values are defined as follows:

ACTIVE: Product device recommended for new designs.

LIFEBUY: TI has announced that the device will be discontinued, and a lifetime-buy period is in effect.

NRND: Not recommended for new designs. Device is in production to support existing customers, but TI does not recommend using this part in a new design.

PREVIEW: Device has been announced but is not in production. Samples may or may not be available.

OBsolete: TI has discontinued the production of the device.

(2) Eco Plan - The planned eco-friendly classification: Pb-Free (RoHS), Pb-Free (RoHS Exempt), or Green (RoHS & no Sb/Br) - please check <http://www.ti.com/productcontent> for the latest availability information and additional product content details.

TBD: The Pb-Free/Green conversion plan has not been defined.

Pb-Free (RoHS): TI's terms "Lead-Free" or "Pb-Free" mean semiconductor products that are compatible with the current RoHS requirements for all 6 substances, including the requirement that lead not exceed 0.1% by weight in homogeneous materials. Where designed to be soldered at high temperatures, TI Pb-Free products are suitable for use in specified lead-free processes.

Pb-Free (RoHS Exempt): This component has a RoHS exemption for either 1) lead-based flip-chip solder bumps used between the die and package, or 2) lead-based die adhesive used between the die and leadframe. The component is otherwise considered Pb-Free (RoHS compatible) as defined above.

Green (RoHS & no Sb/Br): TI defines "Green" to mean Pb-Free (RoHS compatible), and free of Bromine (Br) and Antimony (Sb) based flame retardants (Br or Sb do not exceed 0.1% by weight in homogeneous material)

(3) MSL, Peak Temp. - The Moisture Sensitivity Level rating according to the JEDEC industry standard classifications, and peak solder temperature.

(4) There may be additional marking, which relates to the logo, the lot trace code information, or the environmental category on the device.

(5) Multiple Device Markings will be inside parentheses. Only one Device Marking contained in parentheses and separated by a "~" will appear on a device. If a line is indented then it is a continuation of the previous line and the two combined represent the entire Device Marking for that device.

(6) Lead/Ball Finish - Orderable Devices may have multiple material finish options. Finish options are separated by a vertical ruled line. Lead/Ball Finish values may wrap to two lines if the finish value exceeds the maximum column width.

Important Information and Disclaimer: The information provided on this page represents TI's knowledge and belief as of the date that it is provided. TI bases its knowledge and belief on information provided by third parties, and makes no representation or warranty as to the accuracy of such information. Efforts are underway to better integrate information from third parties. TI has taken and

continues to take reasonable steps to provide representative and accurate information but may not have conducted destructive testing or chemical analysis on incoming materials and chemicals. TI and TI suppliers consider certain information to be proprietary, and thus CAS numbers and other limited information may not be available for release.

In no event shall TI's liability arising out of such information exceed the total purchase price of the TI part(s) at issue in this document sold by TI to Customer on an annual basis.

TAPE AND REEL INFORMATION
REEL DIMENSIONS

TAPE DIMENSIONS

A0	Dimension designed to accommodate the component width
B0	Dimension designed to accommodate the component length
K0	Dimension designed to accommodate the component thickness
W	Overall width of the carrier tape
P1	Pitch between successive cavity centers

TAPE AND REEL INFORMATION

*All dimensions are nominal

Device	Package Type	Package Drawing	Pins	SPQ	Reel Diameter (mm)	Reel Width W1 (mm)	A0 (mm)	B0 (mm)	K0 (mm)	P1 (mm)	W (mm)	Pin1 Quadrant
THS7530PWPR	HTSSOP	PWP	14	2000	330.0	12.4	6.9	5.6	1.6	8.0	12.0	Q1

TAPE AND REEL BOX DIMENSIONS



*All dimensions are nominal

Device	Package Type	Package Drawing	Pins	SPQ	Length (mm)	Width (mm)	Height (mm)
THS7530PWPR	HTSSOP	PWP	14	2000	367.0	367.0	35.0

PWP (R-PDSO-G14)

PowerPAD™ PLASTIC SMALL OUTLINE



4073225-2/1 05/11

- NOTES:
- All linear dimensions are in millimeters.
 - This drawing is subject to change without notice.
 - Body dimensions do not include mold flash or protrusions. Mold flash and protrusion shall not exceed 0.15 per side.
 - This package is designed to be soldered to a thermal pad on the board. Refer to Technical Brief, PowerPad Thermally Enhanced Package, Texas Instruments Literature No. SLMA002 for information regarding recommended board layout. This document is available at www.ti.com <<http://www.ti.com>>.
 - See the additional figure in the Product Data Sheet for details regarding the exposed thermal pad features and dimensions.
 - Falls within JEDEC MO-153

PowerPAD is a trademark of Texas Instruments.

PWP (R-PDSO-G14)

PowerPAD™ SMALL PLASTIC OUTLINE

THERMAL INFORMATION

This PowerPAD™ package incorporates an exposed thermal pad that is designed to be attached to a printed circuit board (PCB). The thermal pad must be soldered directly to the PCB. After soldering, the PCB can be used as a heatsink. In addition, through the use of thermal vias, the thermal pad can be attached directly to the appropriate copper plane shown in the electrical schematic for the device, or alternatively, can be attached to a special heatsink structure designed into the PCB. This design optimizes the heat transfer from the integrated circuit (IC).

For additional information on the PowerPAD package and how to take advantage of its heat dissipating abilities, refer to Technical Brief, PowerPAD Thermally Enhanced Package, Texas Instruments Literature No. SLMA002 and Application Brief, PowerPAD Made Easy, Texas Instruments Literature No. SLMA004. Both documents are available at www.ti.com.

The exposed thermal pad dimensions for this package are shown in the following illustration.

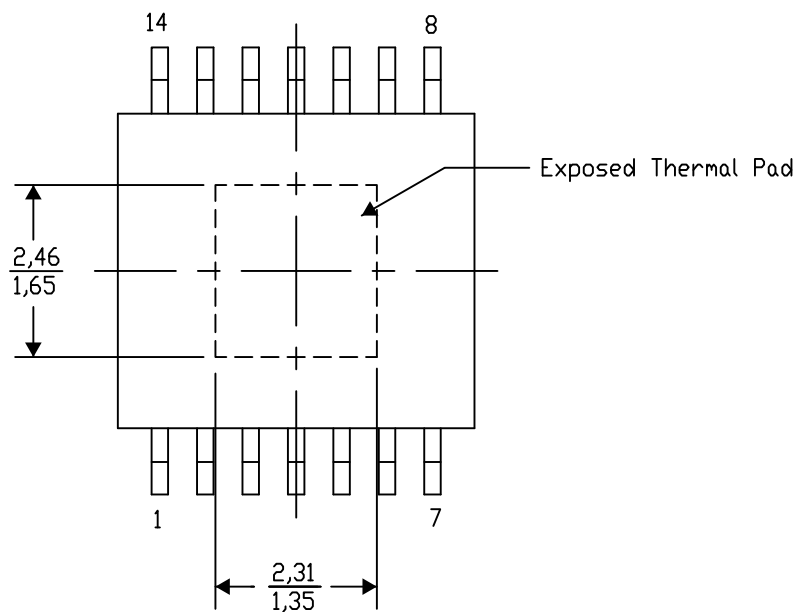

Top View

Exposed Thermal Pad Dimensions

4206332-2/AJ 10/14

NOTE: A. All linear dimensions are in millimeters

PowerPAD is a trademark of Texas Instruments

PWP (R-PDSO-G14)

PowerPAD™ PLASTIC SMALL OUTLINE

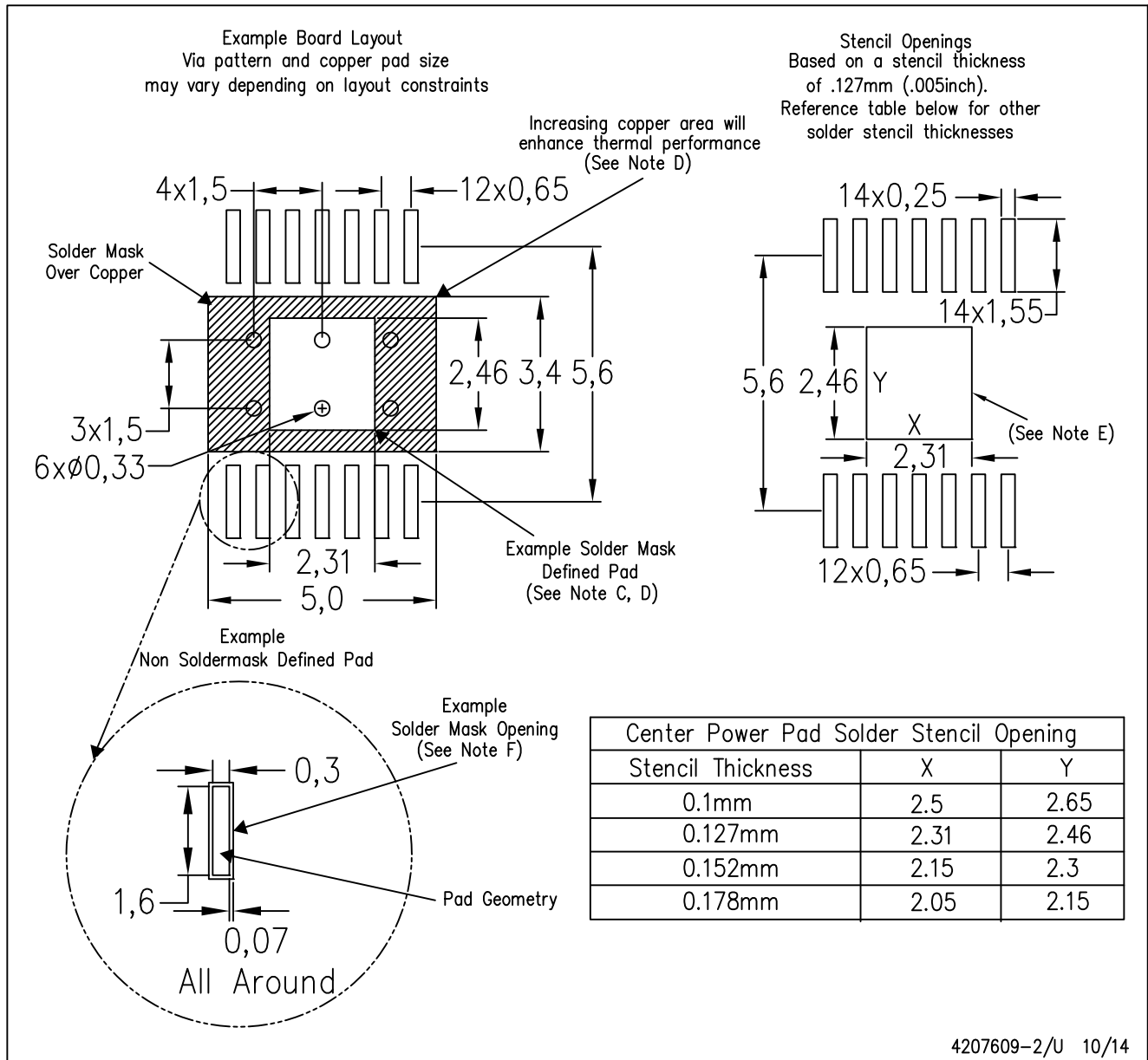

- NOTES:
- A. All linear dimensions are in millimeters.
 - B. This drawing is subject to change without notice.
 - C. Customers should place a note on the circuit board fabrication drawing not to alter the center solder mask defined pad.
 - D. This package is designed to be soldered to a thermal pad on the board. Refer to Technical Brief, PowerPAD Thermally Enhanced Package, Texas Instruments Literature No. SLMA002, SLMA004, and also the Product Data Sheets for specific thermal information, via requirements, and recommended board layout. These documents are available at www.ti.com <<http://www.ti.com>>. Publication IPC-7351 is recommended for alternate designs.
 - E. Laser cutting apertures with trapezoidal walls and also rounding corners will offer better paste release. Customers should contact their board assembly site for stencil design recommendations. Example stencil design based on a 50% volumetric metal load solder paste. Refer to IPC-7525 for other stencil recommendations.
 - F. Customers should contact their board fabrication site for solder mask tolerances between and around signal pads.

THERMAL PAD MECHANICAL DATA

PWP (R-PDSO-G14) PowerPAD™ SMALL PLASTIC OUTLINE

THERMAL INFORMATION

This PowerPAD™ package incorporates an exposed thermal pad that is designed to be attached to a printed circuit board (PCB). The thermal pad must be soldered directly to the PCB. After soldering, the PCB can be used as a heatsink. In addition, through the use of thermal vias, the thermal pad can be attached directly to the appropriate copper plane shown in the electrical schematic for the device, or alternatively, can be attached to a special heatsink structure designed into the PCB. This design optimizes the heat transfer from the integrated circuit (IC).

For additional information on the PowerPAD package and how to take advantage of its heat dissipating abilities, refer to Technical Brief, PowerPAD Thermally Enhanced Package, Texas Instruments Literature No. SLMA002 and Application Brief, PowerPAD Made Easy, Texas Instruments Literature No. SLMA004. Both documents are available at www.ti.com.

The exposed thermal pad dimensions for this package are shown in the following illustration.

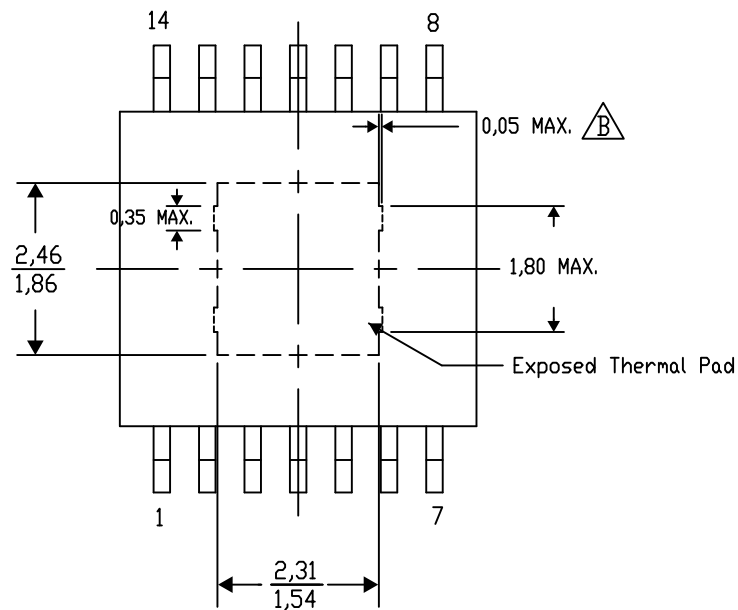

4206332-44/AJ 10/14

NOTE: A. All linear dimensions are in millimeters

 Exposed tie strap features may not be present.

PowerPAD is a trademark of Texas Instruments

PWP (R-PDSO-G14)

PowerPAD™ PLASTIC SMALL OUTLINE

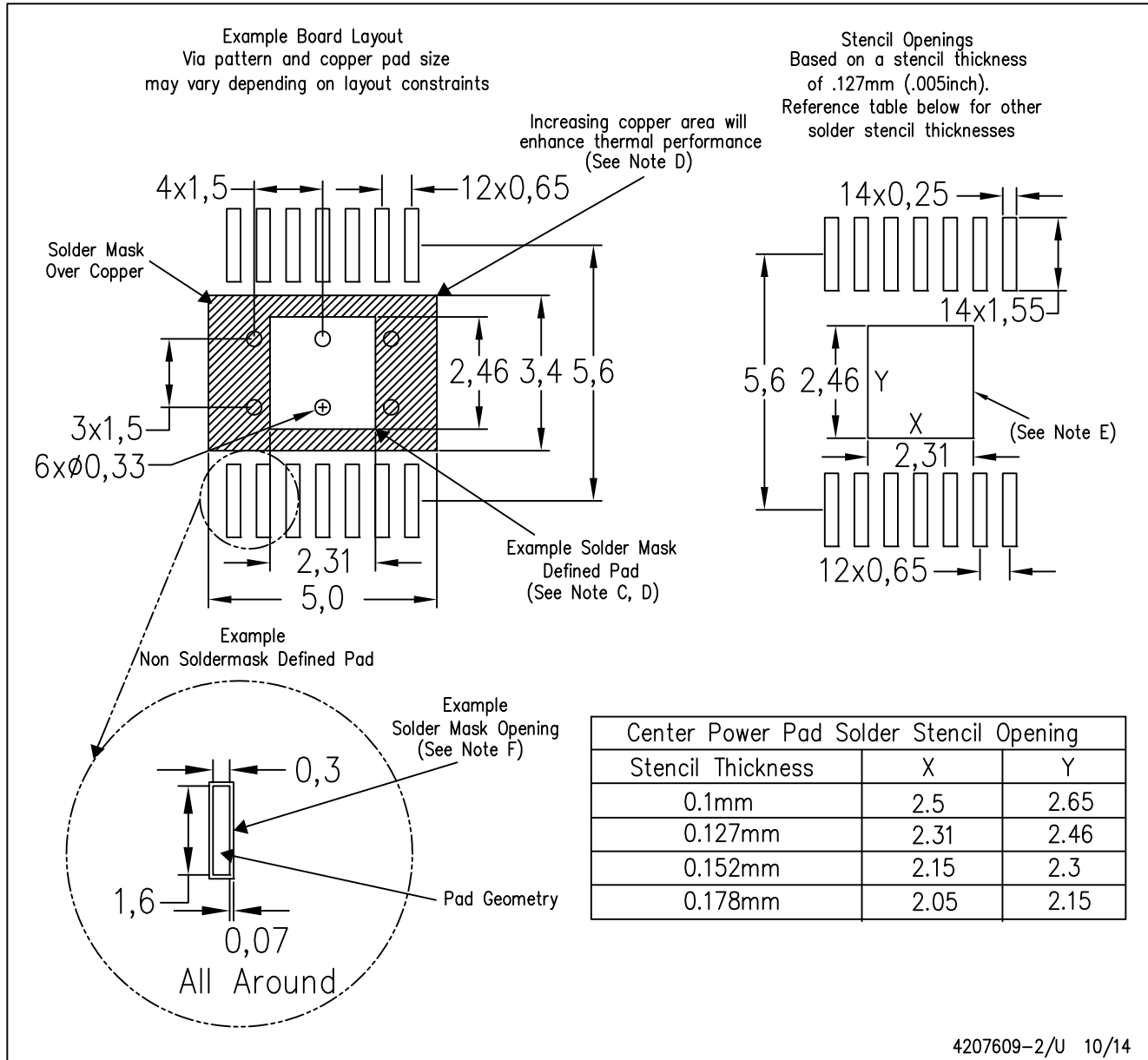

4207609-2/U 10/14

- NOTES:
- All linear dimensions are in millimeters.
 - This drawing is subject to change without notice.
 - Customers should place a note on the circuit board fabrication drawing not to alter the center solder mask defined pad.
 - This package is designed to be soldered to a thermal pad on the board. Refer to Technical Brief, PowerPAD Thermally Enhanced Package, Texas Instruments Literature No. SLMA002, SLMA004, and also the Product Data Sheets for specific thermal information, via requirements, and recommended board layout. These documents are available at www.ti.com <<http://www.ti.com>>. Publication IPC-7351 is recommended for alternate designs.
 - Laser cutting apertures with trapezoidal walls and also rounding corners will offer better paste release. Customers should contact their board assembly site for stencil design recommendations. Example stencil design based on a 50% volumetric metal load solder paste. Refer to IPC-7525 for other stencil recommendations.
 - Customers should contact their board fabrication site for solder mask tolerances between and around signal pads.

IMPORTANT NOTICE

Texas Instruments Incorporated and its subsidiaries (TI) reserve the right to make corrections, enhancements, improvements and other changes to its semiconductor products and services per JESD46, latest issue, and to discontinue any product or service per JESD48, latest issue. Buyers should obtain the latest relevant information before placing orders and should verify that such information is current and complete. All semiconductor products (also referred to herein as "components") are sold subject to TI's terms and conditions of sale supplied at the time of order acknowledgment.

TI warrants performance of its components to the specifications applicable at the time of sale, in accordance with the warranty in TI's terms and conditions of sale of semiconductor products. Testing and other quality control techniques are used to the extent TI deems necessary to support this warranty. Except where mandated by applicable law, testing of all parameters of each component is not necessarily performed.

TI assumes no liability for applications assistance or the design of Buyers' products. Buyers are responsible for their products and applications using TI components. To minimize the risks associated with Buyers' products and applications, Buyers should provide adequate design and operating safeguards.

TI does not warrant or represent that any license, either express or implied, is granted under any patent right, copyright, mask work right, or other intellectual property right relating to any combination, machine, or process in which TI components or services are used. Information published by TI regarding third-party products or services does not constitute a license to use such products or services or a warranty or endorsement thereof. Use of such information may require a license from a third party under the patents or other intellectual property of the third party, or a license from TI under the patents or other intellectual property of TI.

Reproduction of significant portions of TI information in TI data books or data sheets is permissible only if reproduction is without alteration and is accompanied by all associated warranties, conditions, limitations, and notices. TI is not responsible or liable for such altered documentation. Information of third parties may be subject to additional restrictions.

Resale of TI components or services with statements different from or beyond the parameters stated by TI for that component or service voids all express and any implied warranties for the associated TI component or service and is an unfair and deceptive business practice. TI is not responsible or liable for any such statements.

Buyer acknowledges and agrees that it is solely responsible for compliance with all legal, regulatory and safety-related requirements concerning its products, and any use of TI components in its applications, notwithstanding any applications-related information or support that may be provided by TI. Buyer represents and agrees that it has all the necessary expertise to create and implement safeguards which anticipate dangerous consequences of failures, monitor failures and their consequences, lessen the likelihood of failures that might cause harm and take appropriate remedial actions. Buyer will fully indemnify TI and its representatives against any damages arising out of the use of any TI components in safety-critical applications.

In some cases, TI components may be promoted specifically to facilitate safety-related applications. With such components, TI's goal is to help enable customers to design and create their own end-product solutions that meet applicable functional safety standards and requirements. Nonetheless, such components are subject to these terms.

No TI components are authorized for use in FDA Class III (or similar life-critical medical equipment) unless authorized officers of the parties have executed a special agreement specifically governing such use.

Only those TI components which TI has specifically designated as military grade or "enhanced plastic" are designed and intended for use in military/aerospace applications or environments. Buyer acknowledges and agrees that any military or aerospace use of TI components which have **not** been so designated is solely at the Buyer's risk, and that Buyer is solely responsible for compliance with all legal and regulatory requirements in connection with such use.

TI has specifically designated certain components as meeting ISO/TS16949 requirements, mainly for automotive use. In any case of use of non-designated products, TI will not be responsible for any failure to meet ISO/TS16949.

Products

Audio	www.ti.com/audio
Amplifiers	amplifier.ti.com
Data Converters	dataconverter.ti.com
DLP® Products	www.dlp.com
DSP	dsp.ti.com
Clocks and Timers	www.ti.com/clocks
Interface	interface.ti.com
Logic	logic.ti.com
Power Mgmt	power.ti.com
Microcontrollers	microcontroller.ti.com
RFID	www.ti-rfid.com
OMAP Applications Processors	www.ti.com/omap
Wireless Connectivity	www.ti.com/wirelessconnectivity

Applications

Automotive and Transportation	www.ti.com/automotive
Communications and Telecom	www.ti.com/communications
Computers and Peripherals	www.ti.com/computers
Consumer Electronics	www.ti.com/consumer-apps
Energy and Lighting	www.ti.com/energy
Industrial	www.ti.com/industrial
Medical	www.ti.com/medical
Security	www.ti.com/security
Space, Avionics and Defense	www.ti.com/space-avionics-defense
Video and Imaging	www.ti.com/video

TI E2E Community

e2e.ti.com

Mouser Electronics

Authorized Distributor

Click to View Pricing, Inventory, Delivery & Lifecycle Information:

[Texas Instruments:](#)

[THS7530PWPRG4](#)