

ISO VIEW
SCALE 1:1

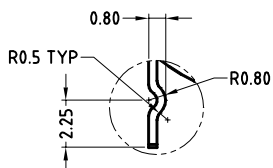

DETAIL A
SCALE 4:1

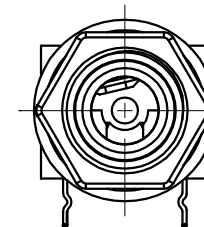
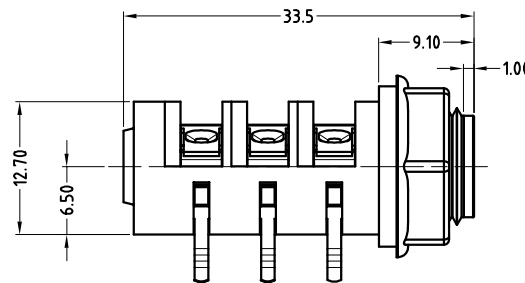
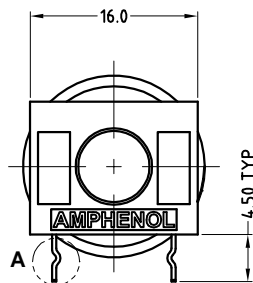
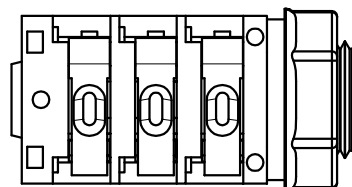
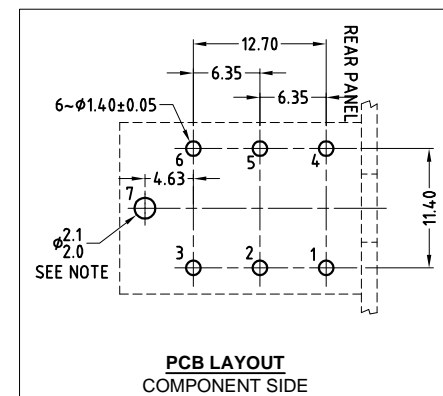
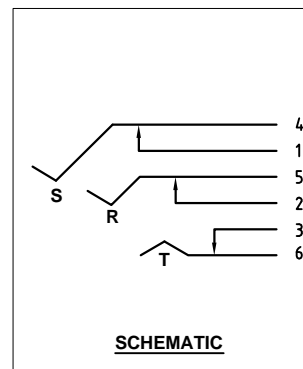
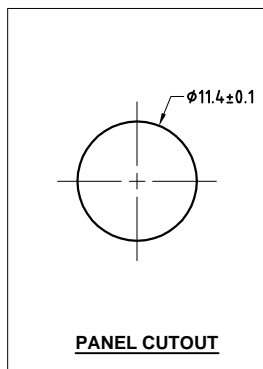
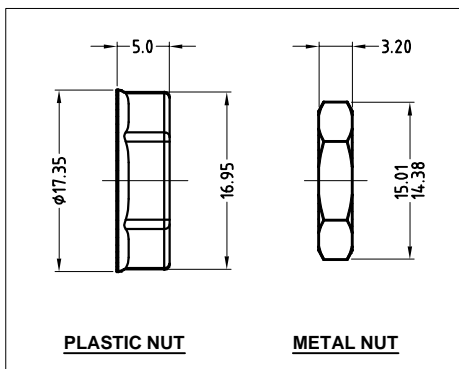

CATALOGUE P/N	ASSEMBLY P/N	NUT OPTIONS
ACJS-PHDR	55010154-502	PLASTIC
ACJS-MHDR	55010154-302	METAL

NOTE: OPTIONAL MOUNTING HOLE FOR SELF-TAPPING M2 SCREW

UNLESS OTHERWISE SPECIFIED TOLERANCE TO BE		THIS DOCUMENT IS THE PROPERTY OF AMPHENOL AUSTRALIA PTY. LTD.. NO PART THEREOF MAY BE REPRODUCED AND USED WITHOUT THE PRIOR WRITTEN CONSENT OF THE OWNER			
LINEAR	ANGULAR	CAD FILE: 55010154502222	DRN: L.V	DATE: 18-06-02	1/4" PHONE STEREO JACK CUSTOMER DRAWING Amphenol Australia Pty Ltd, 2 Finemays Blvd, Keysborough, Vic 3173 DRAWING NO. SHEET 55010154-502-2 2 OF 2
X ± 0.5	X° ± 1°	MATL: REFER TO COMPONENTS	CKD: M.N.H	DATE: 17-05-06	
X,X ± 0.1	X°X' ± 30'	FINISH: REFER TO COMPONENTS	APP'D: P.M	DATE: 17-05-06	
X,X,X ± 0.05	X°X'X" ± 15'	DO NOT SCALE			
DIMENSIONS IN MILLIMETRES		THIRD ANGLE PROJECTION	SCALE: 2:1 UOS	PART No: REFER TO CHART	SIZE: A3

2	CHANGE PLASTIC NUT FROM P/N: 52170018-531 TO P/N: 52170032-531	L.V	31-01-05	8333
1	UPDATE TO COMPLY WITH MODIFIED COMPONENTS	L.V	11-06-03	8184
0	FIRST ISSUE	L.V	18-06-02	----
REV.	CHANGE DETAILS	BY	DATE	CHG/No