

RABBIT Single Board Computers and Software



BL2600 WOLF - MODELS BL2600, BL2610

The BL2600 Wolf single-board computer provides embedded systems engineers a complete and expandable performance package. Two standard models—one with 10/100 Ethernet and one without 10/100 Ethernet - feature the Rabbit 3000® microprocessor at 44.2 and 29.4 MHz respectively, with at least 512K Flash and 512K SRAM (standard).

Programming the BL2600

Programs are developed and debugged using industry-proven Dynamic C® software, which runs on a Windows PC. The programming device is connected via a serial cable, a USB cable, or Ethernet. Comprehensive debugging support includes break points, watch expressions and many other extensive features oriented toward real-time embedded systems programming. An extensive library of drivers and sample programs is provided, including a royalty-free TCP/IP stack for network and Internet communications. Full source code is provided for most library routines.

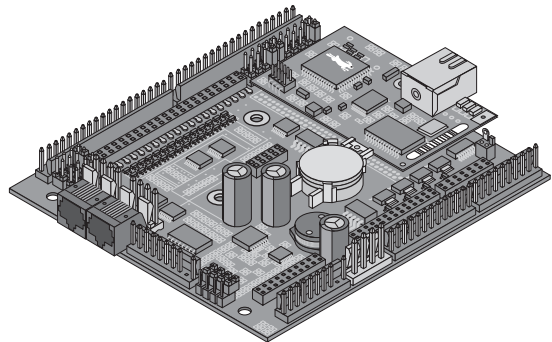

BL2600 Specifications & Features		
Feature	BL2600	BL2610
Microprocessor	Rabbit 3000™ at 44.2MHz	Rabbit 3000™ at 29.4MHz
Ethernet Port	10/100Base-T, 3 LEDs	None
Flash Memory	512K (standard)	
SRAM	512K Program Execution, 256K Data	512K (standard)
Backup Battery	Panasonic CR2477 or equivalent 3V lithium coin type, 950mAh, socket mounted	
Configurable I/O	16: Individually software configurable digital inputs @ ±36VDC, 1.5V switching threshold, or sinking digital outputs up to 40V, 200mA each	
Digital Inputs	16: Hardware-configurable pull-up or pull-down, ±36VDC, switching threshold 1.4V typ.	
High-Current Digital Outputs	4: Individually software configurable, +40VDC, 2 A max. per channel, sinking or sourcing	
Analog Inputs	8 channels with 11-bit resolution, software selectable ranges Unipolar: 1, 2, 2.5, 5, 10, 20VDC; Bipolar: ±1, ±2, ±5, ±10VDC; Four of the eight channels maybe hardware-configured for 4-20mA, 12 kHz update rate	
Analog Outputs	4 channels, 12-bit resolution, buffered (0-10 V DC, ±10VDC), 4-20mA, 12kHz update rate	
RabbitNet	Compatible Expansion Cards: Digital I/O, A/D, D/A, Relay, Keypad Display Interface	
Serial Ports	Up to 5 serial ports: • 1 RS-485 or 1 RS-232 • 2 RS-232 or one RS-232 (with CTS/RTS) • 1 clocked serial port multiplexed to 2 RS-422 SPI master ports • 1 CMOS compatible serial port for programming/debug	
Serial Rate	Max. async = CLK/8, Max. sync = CLK/2	
Real-Time Clock	Yes	
Timers	Ten 8-bit timers (6 cascadable from the first) and one 10-bit timer with 2 match registers	
Watchdog/Supervisor	Yes	
Power	9/36VDC, 25W max. (includes power to RabbitNet expansion boards)	
Operating Temperature	-40° to +70°C (-40° to +85°C without battery)	
Humidity	5-95%, noncondensing	
Connectors	One Ethernet and two RabbitNet™ RJ-45 connectors Two polarized, 9-position with 0.1" pitch friction-lock connectors Three 4-position power terminals with 0.156" pitch friction-lock connectors Two 20-position terminals with 0.1" pitch (and 2 x 20 IDC headers) friction-lock connectors One 13-position terminal with 0.1" pitch (and 2 x 13 IDC header) friction-lock connector One 10-position terminal with 0.1" pitch (and 2 x 7 IDC header) friction-lock connector One 2 x 5 IDC, 1.27 mm pitch (BL2600) programming port One 2 x 5 IDC, 2 mm pitch (BL2610) programming port	
Board Size	4.85" x 4.96" x 1.00" (123 x 126 x 25mm)	

For quantities of 5 and up, call for quote.

MOUSER STOCK NO.	Description	Price Each
Mfr. Mfr. Part No.		
BL2600 Wolf Board		
812—20-101-0889	BL2600 Board w/ 10/100Base-T Ethernet - RoHS	289.00
812—20-101-0891	BL2610 Board w/o 10/100Base-T Ethernet - RoHS	269.00
Product Accessories		
812—20-101-0879	RN1600 RabbitNet Keypad/Dsply Interface Card-RoHS	69.00
812—20-101-0688	RN1300 RabbitNet D/A Expansion Card	89.00
812—20-101-0616	RN1200 RabbitNet Digital I/O Expansion Card	89.00
812—20-101-0612	RN1100 RabbitNet Digital I/O Expansion Card	89.00
694—20-101-0468	SF1000 4MB Serial Flash Expansion - RoHS	79.00
694—20-101-0467	SF1000 8MB Serial Flash Expansion	89.00
694—20-101-0580	RabbitLink Card for Remote Debug via Ethernet/Internet - RoHS	129.00
694—101-0589	Rabbit Cloning Board to Copy Compiled Software Board to Board	89.00
694—20-151-0178	RS-232-to-USB Converter Cable for USB only PCs	39.00
694—20-101-0542	1.27mm Connector for 10/100Base-T Option	25.00
812—20-101-0581	Connectivity Kit	18.00

SR9000 SMART START SYSTEM

The Smart Start is a modular and expandable embedded control system designed for demanding real-time control and data acquisition applications. Multiple I/O card options-including digital, A/D, D/A, and relays-allow users to closely match their specific I/O needs. The Smart Star CPU card comes in both Ethernet and non-Ethernet versions, and a cost-effective keypad/display is also available.

Ethernet connectivity - CPU card with or without Ethernet

Flexible functionality - modular configuration to easily interchange or replace individual I/O cards

Multiple I/O card options - digital I/O, A/D, D/A, relay

Expandable - up to 168 I/O

Cost-effective - low cost per I/O

Optional keyboard/display - backlit 122 x 32 pixel graphic LCD with 7 user-relegendable keys, 7 LEDs

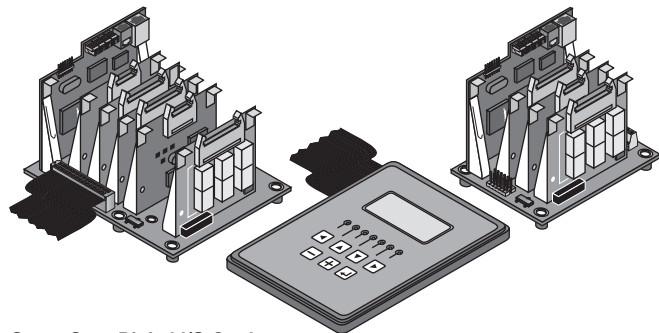

Tool Kit

MOUSER STOCK NO.	Description	Price Each
Mfr. Mfr. Part No.		
812—101-0427	Smart Start Tool Kit (board not included)	458.00

Smart Start Backplane

812—20-101-0512	SR9010 7-slot - RoHS	99.00
812—20-101-0487	SR9050 3-slot	79.00

Keyboard/Display Options

694—20-101-0601	Keypad/Display Unit, 3.3 Volt, No Case - RoHS	79.00
694—20-101-0465	Keypad/Display Unit, 5 Volt, No Case	79.00

Product Options and Accessories

812—101-0504	Cable and Mounting Hardware	20.00
812—540-0069	Keypad/Display Unit Cable 5"	15.00
812—151-0127	Connector Adapter Board	40.00

Smart Start CPU Card

812—101-0387	SR9100	125.00
812—101-0815	SR9100 512K SRAM	159.00
812—20-101-0486	SR9150 Ethernet - RoHS	159.00
812—20-101-0738	SR9150 Ethernet, 512K SRAM - RoHS	219.00
812—20-101-0506	SR9160	119.00
812—101-0775	SR9160 512K SRAM	179.00

Programming/Development Tools

694—20-101-0580	RabbitLink Card	129.00
694—101-0589	Rabbit Cloning Board	89.00
694—540-0070	RS-232-to-USB Converter Cable	39.00

Smart Start Digital I/O Cards

MOUSER STOCK NO.	Description	Price Each
Mfr. Mfr. Part No.		
812—20-101-0389	16 inputs and 8 outputs, sinking	49.00
812—20-101-0437	16 inputs and 8 outputs, sourcing - RoHS	69.00
812—20-101-0390	8 inputs and 16 outputs, sinking - RoHS	49.00
812—101-0391	8 inputs and 8 outputs, sinking	59.00

Smart Start A/D Cards

812—20-101-0392	Eleven 12-bit analog inputs (0-10V)	79.00
812—101-0423	Eleven 12-bit analog inputs (±10V)	79.00
812—20-101-0444	Eleven 12-bit analog inputs (4-20mA) - RoHS	79.00

Smart Start D/A Cards

812—20-101-0393	Eight 12-bit analog outputs (0-10V)	129.00
812—101-0394	Eight 12-bit analog outputs (±10V)	149.00
812—20-101-0445	Eight 12-bit analog outputs (4-20mA) - RoHS	129.00

Smart Start Relay Cards

812—20-101-0395	6 relays: 1SPDT, 5 SPST, including snubbers	79.00
812—20-101-0440	8 SPDT relays, no on-board snubbers - RoHS	79.00

Smart Start Field Wiring Terminals

812—20-101-0515	Screw-type (A/D, D/A) - RoHS	19.00
812—20-101-0421	Pluggable (A/D, D/A)	44.00
812—20-101-0512	Screw-type (I/O, Relay 8)	99.00
812—20-101-0420	Pluggable (I/O, Relay 8)	49.00
812—101-0516	Screw-type (Relay 6)	19.00
812—101-0422	Pluggable (Relay 6)	29.00